

# PREFACE

This operator's manual contains handling tips and precautions for safe operation of your **TYM F25R(H),Rn(hn)/F36R(H),Rn(hn)/F42R(H), Rn(hn)/F50R(H), Rn(hn)** tractor. Read it carefully before you operate your tractor and make sure that you have a full understanding of this manual. This will ensure correct operation and to keep the tractor optimum condition.

After reading the manual, keep it close to the tractor for immediate reference. When you loan your tractor to someone else, loan the manual as well.

In case the manual is lost or damaged, please contact your local authorized dealer for a copy. Some parts of this product may have been changed for the improvement of quality or for safety reasons, in which case the photographs or drawings of the parts in this booklet may not be the same as the actual parts installed on this product. If you find anything in this manual unclear or need further explanation, please contact your authorized dealer.

※ Regarding the purpose of this machine

Do not modify the machine or try to do the job which is beyond purpose of this machine. Otherwise it may cause the warranty cancellation. (Refer to warranty statement for detail)

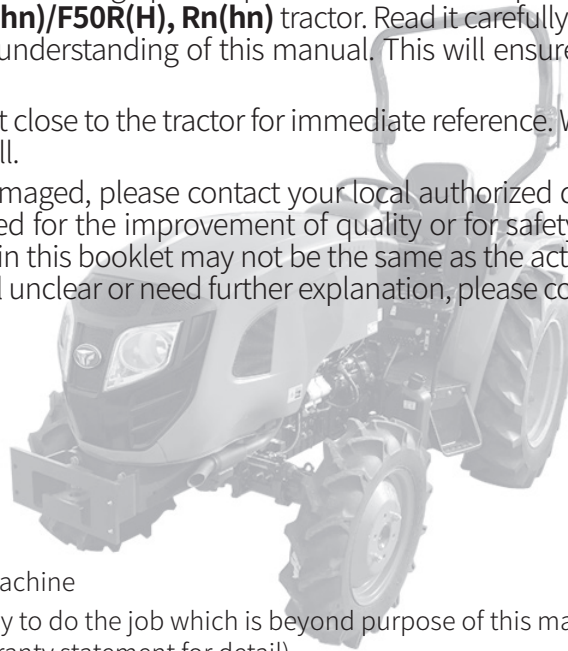



# TABLE OF CONTENTS



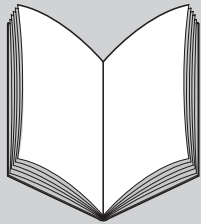

## *SECTION*



- FOR SAFE OPERATION ..... 1
- REGARDING WARRANTY SUPPORT ..... 2
- SPECIFICATION ..... 3
- DESCRIPTION OF OPERATING SYSTEM ..... 4
- CONTROLS AND COMPONENTS ..... 5
- PERIODIC CHECKS AND MAINTENANCE ..... 6
- DIAGNOSIS AND TROUBLE SHOOTINGS..... 7
- STORAGE AND DISPOSAL ..... 8

# SAFETY AND VEHICLE DAMAGE WARNING

This manual includes information titled as **DANGER, WARNING, CAUTION, IMPORTANT**. These safety marks stand for the safety precaution so follow the instruction with special attention:

 <b>DANGER</b>	<p>This symbol indicates that a condition may result in harm, fatal injury or death to you or other persons if this instruction is ignored.</p>
 <b>WARNING</b>	<p>This symbol indicates that a condition may result in harm, serious injury or death to you or other persons if this instruction is ignored.</p>
 <b>CAUTION</b>	<p>This symbol indicates that a condition may result in damage to your vehicle or its equipment if this instruction is ignored. Also this symbol alerts the operator's unstable operation.</p>
 <b>IMPORTANT</b>	<p>This symbol indicates emphasis on notable characteristics of working procedures, and information about technology for easier operation.</p>
<b>NOTE</b>	<p>This instruction is to give an additional description to operator so that he/she can operate the machine more effectively.</p>

This manual includes "Very important safety tips for safe operation" as a chapter. Be sure to read this chapter before initial operation.

# SYMBOL MARKS OF CONTROLLER

This manual includes symbol marks of the controller to simplify operations for maneuverability and maintenance. These meanings are as below, so carefully read it for a proper function.



PTO



Left side indicator



Right side indicator



Preheat



Engine oil pressure



Battery



Parking Brake (Brake)



High beam



Low beam



DPF



Brake Release



Water Separator Indicator



QT Indicator



4WD Indicator



EMG Failure Indicator



Engine Hydraulic Pressure Indicator



Fuel Gauge



High Speed

## "USE AND DISPOSAL" POLICY CONCERNED WITH ENVIRONMENT PRESERVATION

We try our best to preserve the environment, and are always concerned about our environmental impact at each step of planning, development, production, distribution, use and disposal of products, and for our overall operations through an “environmentally friendly” management system. We comply with international environmental regulations, environmental regulations designated by country and local authorities and other requirements with which we are in agreement, and we work towards the prevention of environmental pollution and the conservation of resources. We provide environmental education and have an awareness campaign to raise environmental awareness among all our employees and members of the supporting companies.

We introduce the “Use and Disposal” policy concerned with environment preservation as follows.

1. Please read the operator’s manual though for global environment protection. Overload on the machine shortens the product life and increases the harmful exhaust gas, which cause air pollution due to the incomplete combustion.
2. When replacing various fluids (for engine, transmission, hydraulics, etc.) by yourself, don’t dispose the used oil to anywhere not recommended. It can pollute the ground and water. Please contact your local dealer to dispose it legally.
3. Observe the operator’s manual and store or dispose the waste product properly. Rust, oil, etc. leaked from waste product improperly stored can pollute the ground and water. Accordingly for a waste product disposal, contact the necessarily “approved waste collection and recycling facility” to discard the used materials legally.

# 1. FOR SAFE OPERATION

<b>SAFETY PRECAUTIONS.....</b>	<b>1-2</b>
BEFORE USING THE MACHINE .....	1-2
BEFORE WORKING.....	1-11
WHILE WORKING.....	1-16
AFTER USING THE MACHINE .....	1-17
PRECAUTION FOR PROLONGED STORAGE .....	1-21
OTHER.....	1-23
<b>DECAL MOUNTING LOCATION .....</b>	<b>1-31</b>
<b>DECAL.....</b>	<b>1-33</b>
CAUTIONS FOR DECAL MAINTENANCE .....	1-36

## SAFETY PRECAUTIONS

If the instructions in this chapter are ignored, it may cause a machine failure, a fatal accident with injury or death.

For further detailed information, refer to each chapter.

### NOTE

- Please understand that some of the figures or contents in this manual may not match with your own machine due to the product variation.
- This tractor is not designed for road driving. Please use a truck to move this machine on the public roads.

## BEFORE USING THE MACHINE

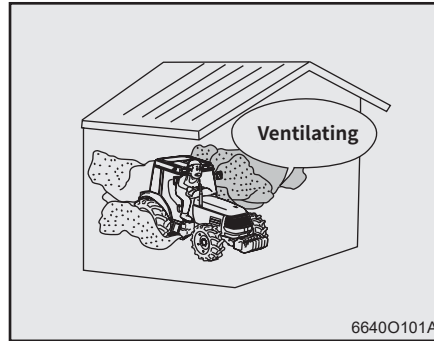

### ⚠ WARNING

Beware of exhaust gas;

- Running the engine, repairing (tightening) any painted part or grinding any painted area should be performed only in a well-ventilated area.

If this instruction is ignored, the exhaust gas or dust can cause intoxication and lead to fatal consequences.

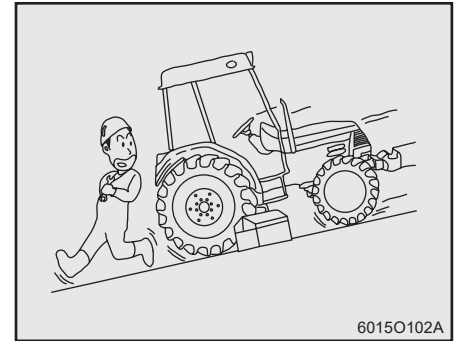

### ⚠ WARNING

Wide and flat enough area;

- Inspect or repair the tractor on a wide and flat area.

If this instruction is ignored, an unexpected accident may occur, such as overturning of the tractor.



**! WARNING**

Clean and arranged place;

- Do not mess the place by dust, mud, oil, or parts

If this instruction is ignored, an unexpected accident may occur.

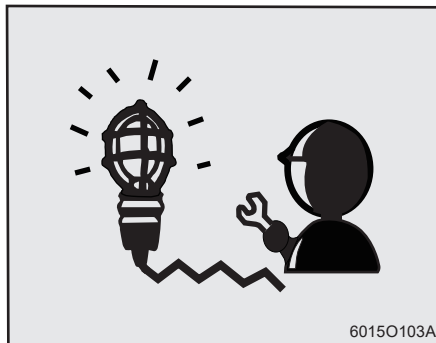
**! WARNING**

Carry out maintenance in a well-lit place;

- Make sure work area is properly lighted.
- Use safety work lights with protective covering when working inside or under the machine.

If this instruction is ignored, an unexpected accident may occur, possibly fire or explosion.

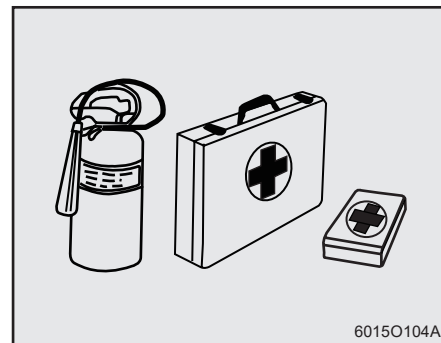
**! WARNING**

Prepare for emergencies;

- Keep a first aid kit and fire extinguisher handy at all times while operating machine.

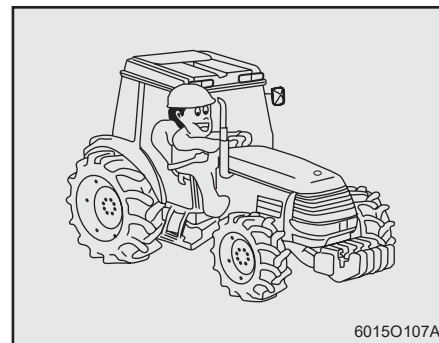
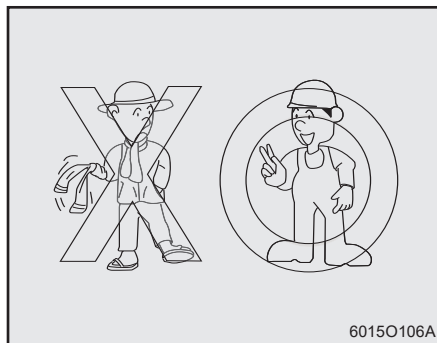
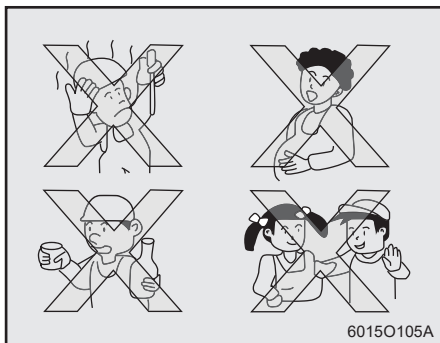

**! WARNING**

Do not drive if you are;

- Unable to concentrate because of fatigue, under treatment of medicine.
- Under the influence of alcohol
- Pregnant
- Under the age of 18

**! WARNING**

Wear properly for the job;

- Hair band, loose clothing is not allowed. Wear tight clothes, work hat, and work shoes which have rough bottoms against slippery surface.

If this instruction is ignored, you will be exposed to a risk of being entangled, slipping, or falling.

**! WARNING**

Use only recommended implements;

- Be sure to use only implements which are recommended by manufacturer.

If this instruction is ignored, an unexpected accident may occur or tractor may not perform properly.

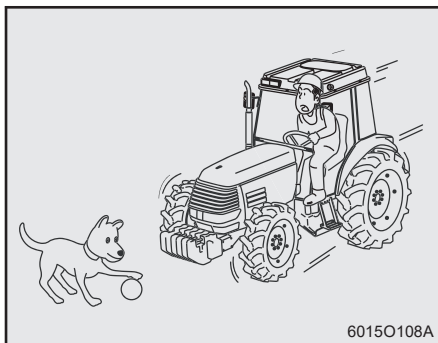

**⚠ WARNING**

Start the machine slowly after reminding bystander;

- Start the engine after reminding bystanders of your intention. Do not start the machine abruptly.

If this instruction is ignored, unexpected accident or injury can happen.

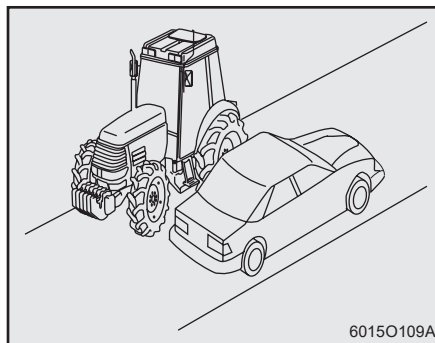

**⚠ WARNING**

Pay attention to the shoulder of the road;

- When moving along the unpaved road with ditches or slanted sides, pay attention to the shoulders.

If this instruction is ignored, there is a risk of falling over.

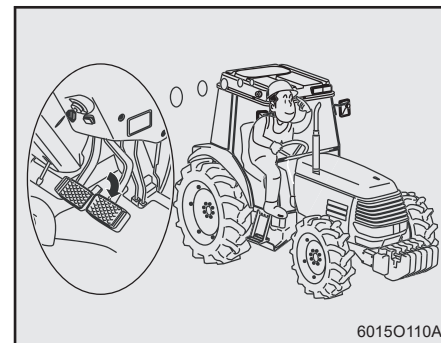

**⚠ WARNING**

Interlock the brake pedals (left and right) when driving on a road;

- Make sure to interlock the brake pedals (left and right) when driving on a road

If this instruction is ignored, there is a risk of abrupt turning or overturning due to one-sided braking.

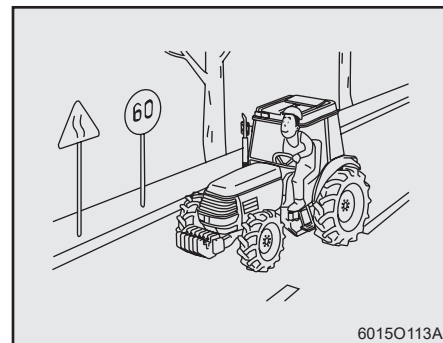
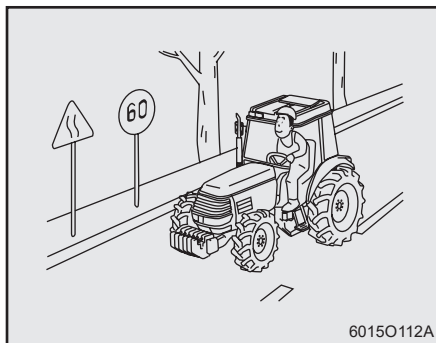
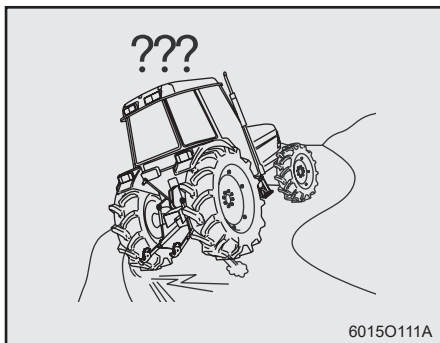

**⚠ WARNING**

Avoid rapid starting, braking, turning, and excessive speed;

- Start and stop the tractor slowly. Reduce engine speed when making a turn and driving on hilly or curved roads.

If this instruction is ignored, there is a risk of overturning or damage to the machine.

**⚠ WARNING**

Observe traffic regulations and drive safely;

- When driving on the road, observe the traffic regulations and wear a hard hat and seat belt.

If this instruction is ignored, there is a risk of accident or injury.

**⚠ WARNING**

Observe traffic regulations when driving on a road safely;

- If the machine is broke down and stopped on the road, move the machine to a safe place out of the road.

If this instruction is ignored, there is a risk of accident or injury.

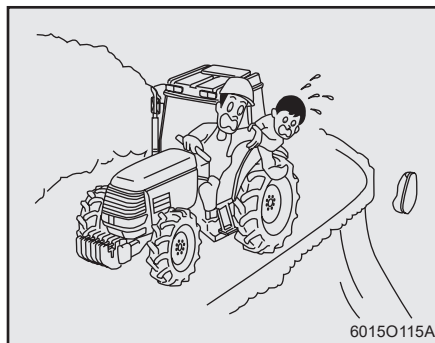
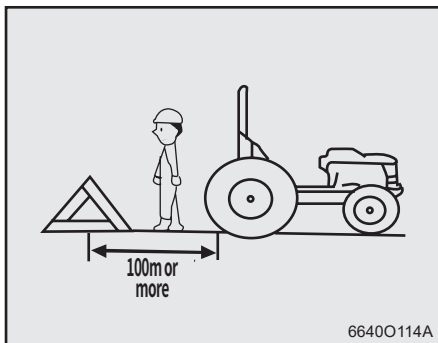

### WARNING

Put machine shut down sign if the machine is stopped on the road;

- If the tractor is stopped on the road due to the machine failure, put the machine shut down sign (Emergency triangle reflex reflector) at least 100~200 yards before failed machine in accordance with local traffic laws.

If this instruction is ignored, the machine can be hit by a car and cause a traffic accident with injury or death.

### WARNING

Only driver should be aboard the tractor while in operation;

- This tractor is designed to allow only one operator. The driver must not allow anyone else to get on the tractor.
- Especially never allow children on the machine while in use.

If this instruction is ignored, an unexpected accident may occur.

### WARNING

Do not allow anyone near while operating the tractor or implement;

- When engaging or disengaging the implement by moving the tractor, make sure that no one is around the tractor or between the implement and the tractor.

If this instruction is ignored, there is a risk of accident or injury.

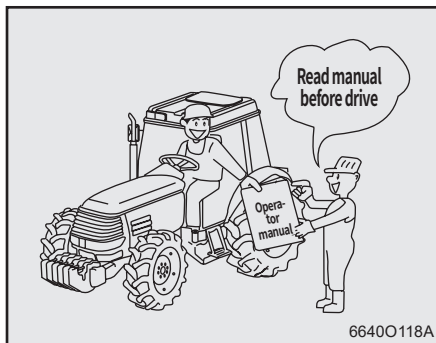

**! WARNING**

Precautions for children;

- Fully warn the children and keep them away from the tractor at all times.

If this instruction is ignored, unexpected accident of injury can happen.

**! WARNING**

Properly train anyone operating;

- Explain the handling tips in detail and make sure the driver reads the Manual before driving.

If this instruction is ignored, there is a risk of death, serious injury, or damage to tractor.

**! WARNING**

Use Pesticides safely;

- Careless use of agricultural chemicals such as disinfectants, herbicide, pesticides, rat poison, and fertilizer can be harmful to environment and human body. Be sure to observe all relevant regulation and instructions to use the agricultural chemicals efficiently and safely. Then it may prevent injury or accident.

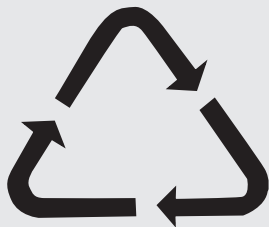

6015O120A

 **WARNING**

Observe all relevant regulations for disposal;

- Be sure to observe all relevant regulations when you dispose of the engine oil, transmission oil, fuel, coolant, filters and battery.
- Never dispose the used oil directly to the river or drainage, follow legal procedures.



6015O121A

 **WARNING**

Observe all relevant regulations for disposal;

- Careless disposal of waste product can be harmful to environment and ecosystem.
- When draining the fuel and oil, use a proper container that is not leaking, not food or beverage containers to prevent from drinking. Do not bury the waste product in the ground or dispose to drainage.

 **WARNING**

No smoking or open flame when fuelling;

- Do not smoke or use match or lighter while refueling.
- If this instruction is ignored, fuel can catch fire and lead to explosion or fatal injury with burn.

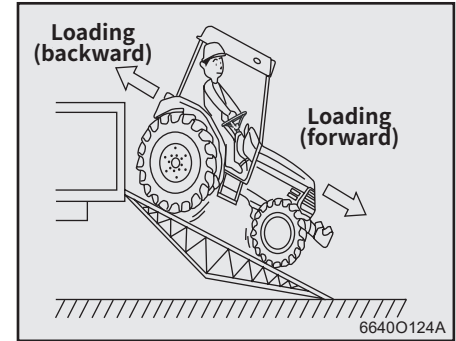
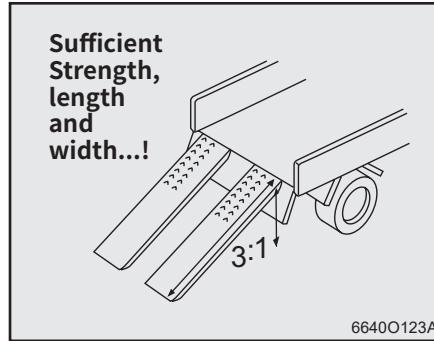
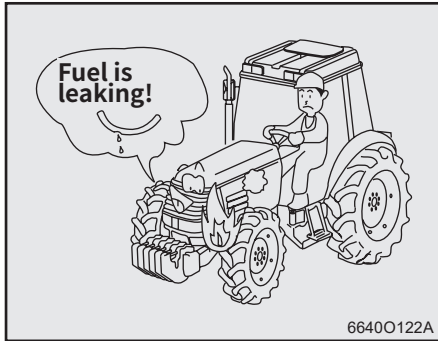

**! WARNING**

Inspect for fuel leaking;

- Check the fuel lines and hoses for damage or leakage

If this instruction is ignored, there is a risk of fire.

**! WARNING**

Consider the strength, length and width of loading ramps before using;

- Loading or unloading must be done on a flat and safe place, the tractor engine switched off, and the parking brake engaged. The loading ramps must be non-slip and have sufficient strength, length, and width for the tractor.

If this instruction is ignored, the tractor may roll backwards or fall off causing accident or injury.

**! WARNING**

Move the tractor backward when loading, and forward when unloading;

- Move the tractor backward when loading it on the truck, and forward when unloading from the truck.

If this instruction is ignored, the tractor may roll or fall off causing accident or injury.



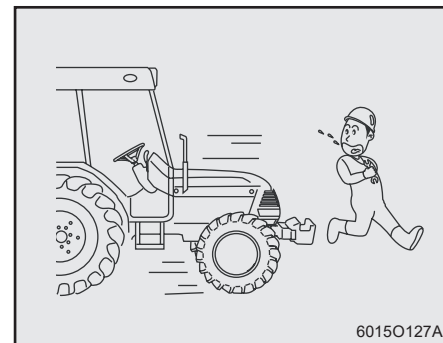
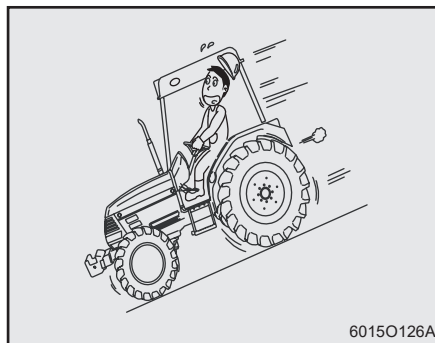
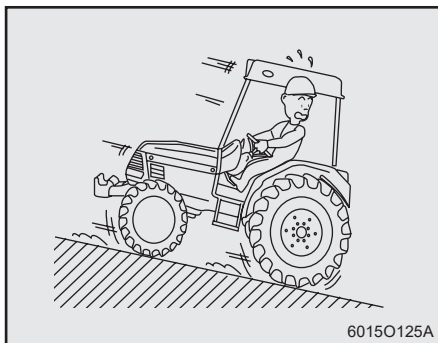

## BEFORE WORKING

1

### WARNING

Be careful when driving on the loading ramps;

- Be careful when driving on the loading ramps. Do not disengage the clutch, shift the main shift, range shift, or forward/reverse lever.

If this instruction is ignored, the tractor may roll backwards or fall causing accident or injury.

### WARNING

Do not shift gears on slopes or on the loading ramps;

- When driving on slopes or on loading ramps, select the proper shift gear before approaching the loading ramps and then do not shift the gear on the loading ramps.

If this instruction is ignored, there is a risk of slipping, rolling, or overturning.

### CAUTION

Stop the engine before maintenance;

- Stop the engine before maintenance when checking, repairing or cleaning the machine.

If this instruction is ignored, there is a risk of injury.

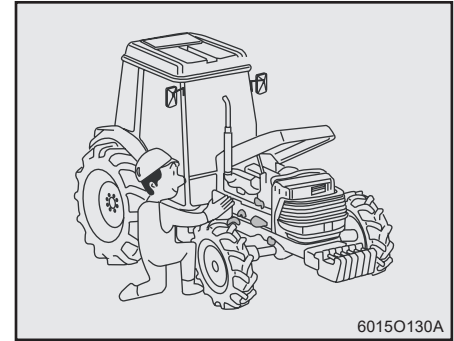
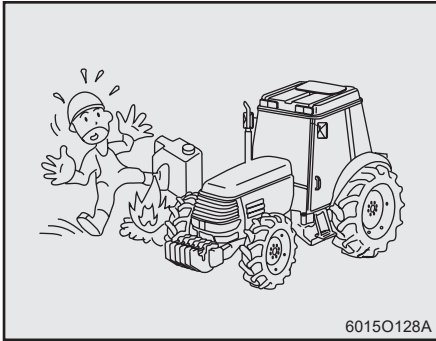

**⚠ DANGER**

Stop and cool down the engine before fueling or lubricating;

- Do not fill the fuel while the engine is running or machine is hot.

If this instruction is ignored, fuel can catch fire or lead to fatal injury with burn.

**⚠ DANGER**

No fire or spark near to the battery;

- No fire or spark near to the battery while checking and charging the battery.

If this instruction is ignored, the battery can cause a blaze or explosion and lead to a fatal injury or death.

**⚠ DANGER**

Remove dirt and debris from muffler and engine before operating;

- Clean if there is dust, debris or fuel on the engine or muffler before operating the machine every day.

If this instruction is ignored, there is a risk of fire.

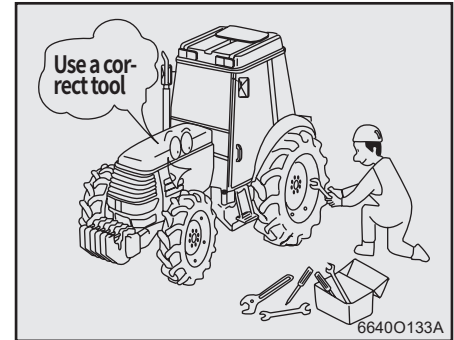
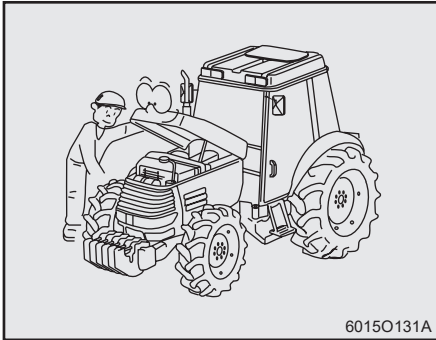

### ⚠ WARNING

Check electrical component and wire harness;

- Check before work if the wire harnesses are burned or stuck on any other component, if the cord cover is peeled off or if the wire connectors are loose.

If this instruction is ignored, the electrical short can cause fire and injury.

### ⚠ CAUTION

Do not over inflate tires;

- When filling tires with air, do not inflate it beyond the maximum pressure stated in this manual. (Refer to P5-22 of Proper inflation pressure)

If this instruction is ignored, the tire may blow out, causing an injury.

### ⚠ CAUTION

Use correct tools;

- Use proper tools to carry out all maintenance procedure. Also have available the required tools in the tractor at all times.

If this instruction is ignored, there is a risk of accident due to poor maintenance.

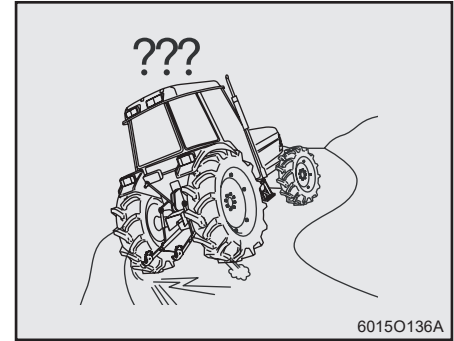
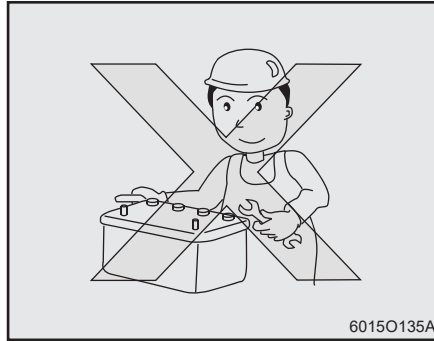
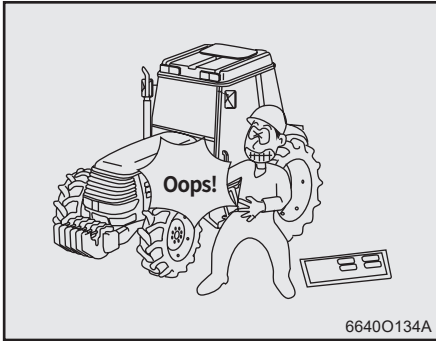

 **CAUTION**

Secure hood and side covers before operating tractor;

- After detaching the covers for checking or maintenance, make sure to put them back in their place.

If this instruction is ignored, there is a risk that you may get entangled in the tractor or get injured.

 **CAUTION**

Observe correct procedures when installing or removing the battery;

- Connect the (+) terminal first when installing the battery, and disconnect the (-) terminal first when removing it.

If this instruction is ignored, there is a risk of burn or fire due to short circuit.

 **WARNING**

It is necessary to inspect the brake and steering wheel;

- Check if the brakes work properly and evenly on both sides or if the steering wheel is loose.

If this instruction is ignored, there is a risk of accident.

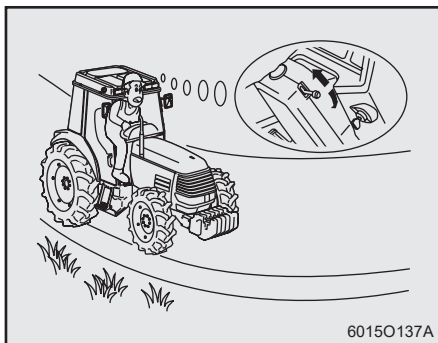

**⚠ WARNING**

Lock tilt lever and telescopic knob when adjusting steering wheel;

- Except when you adjust the steering wheel, make sure that the tilt lever and telescopic knob are secured in the "No" and "Lock" positions.

If this instruction is ignored, the tractor may not turn properly, causing an accident.

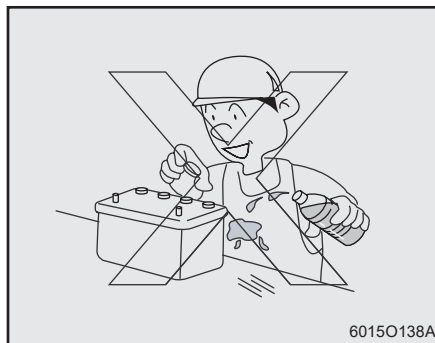

**⚠ DANGER**

Avoid contact with the battery solution;

- Be careful that your body or your clothes do not come in contact with the battery solution. If it contacts your skin, wash immediately with water.

If this instruction is ignored, it can burn your skin or clothes.

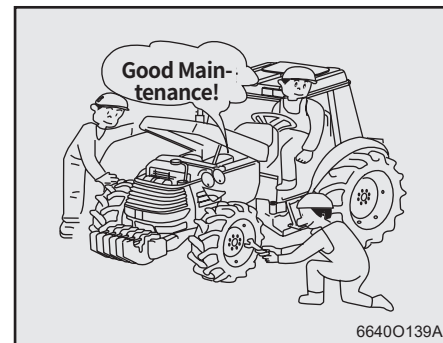

**⚠ WARNING**

Be sure to check before and after using machine;

- Be sure to check the machine before and after using. Especially inspect and repair controls such as clutch, brake, lever, etc.

If this instruction is ignored, the machine can be broken or lead to an accident or injury.

## WHILE WORKING

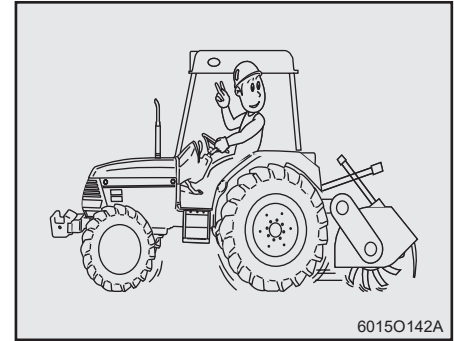
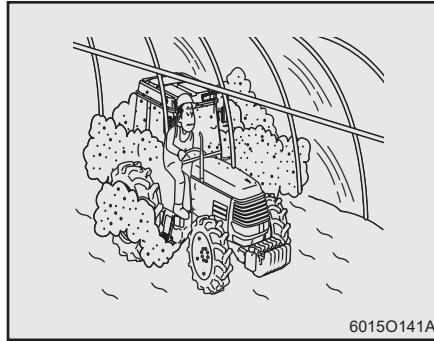
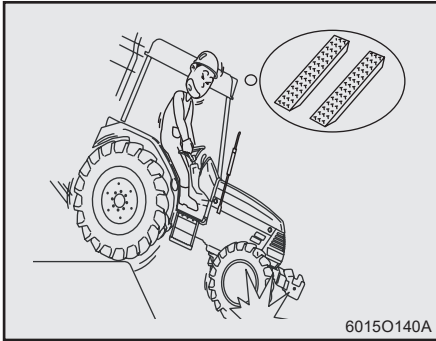

### **WARNING**

Use the loading ramps when crossing a ditch or a dike;

- Be sure to use the loading ramps when crossing a ditch or dike, or when passing through soft land. The loading ramps must be suitable for the tractor in width, length and strength.

If this instruction is ignored, there is a risk of accident that the tractor may slip or turn over.

### **WARNING**

Properly ventilate when working in a green house;

- Ventilate the green house to let out the exhaust gas.

If this instruction is ignored, the exhaust gas can cause intoxication and lead to fatal consequences.

### **WARNING**

Pay attention and keep hands on the steering wheel while driving;

If this instruction is ignored, there is a risk of accident or injury.

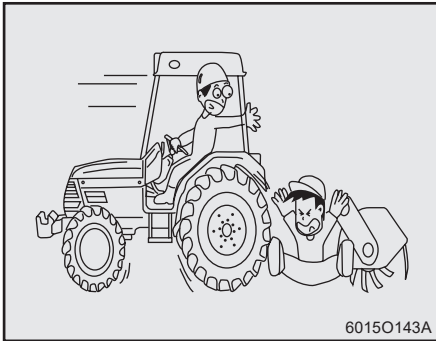

**! WARNING**

Do not allow anyone near while operating the tractor or implement;

- When engaging or disengaging the implement by moving the tractor, make sure that no one is around the tractor or between the implement and the tractor.

If this instruction is ignored, there is a risk of accident or injury.

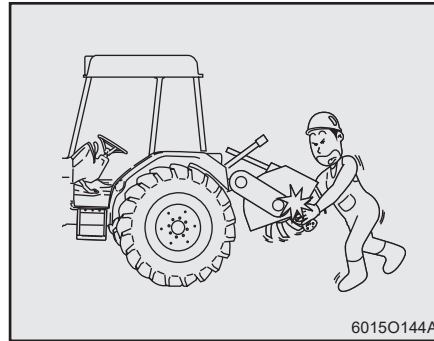

**! WARNING**

Stop the engine when removing grass, etc. from blades of the cultivator;

- Stop the engine when removing grass, etc. from blades of the cultivator and lock the flow control valve not to lower the implement.

If this instruction is ignored, there is a risk that you will get entangled in the cultivator or sustain a serious injury due to lowering the implement.

## AFTER USING THE MACHINE

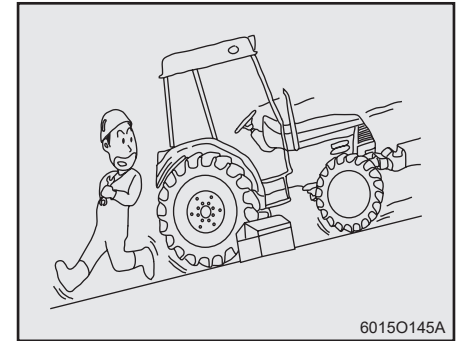

**! WARNING**

Perform the maintenance on a level and safe location;

- Perform the maintenance on a level and safe location that will keep the tractor in place and will not cause a risk to people passing by. Before carrying out the maintenance, place blocks at the front and rear tires to prevent movement.

If this instruction is ignored, an unexpected accident may occur, such as overturning of the tractor.

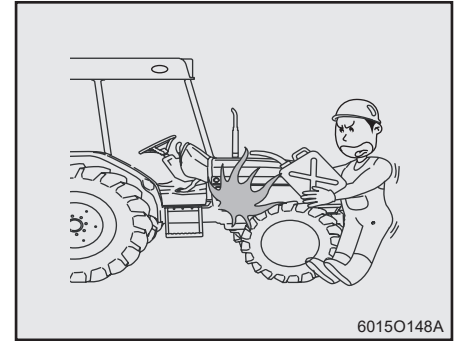
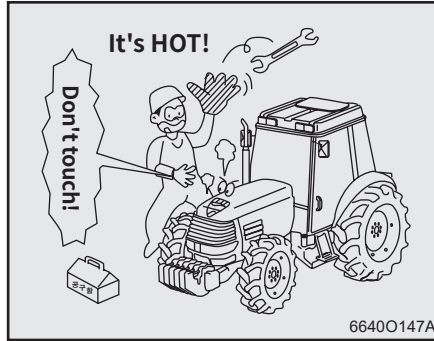
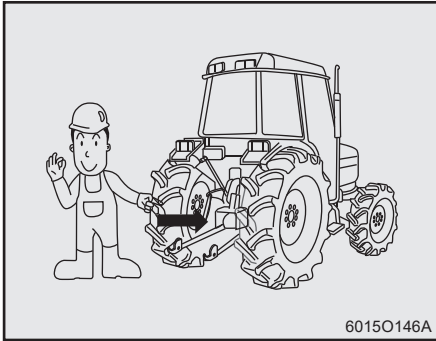

 **CAUTION**

Cover the PTO shaft when not in use;

- When the PTO shaft is not in use, apply grease and keep it covered.

If this instruction is ignored, there is a risk that you may get entangled or get injured. Implement shaft installation on the PTO shaft will not be easy due to the rust on it.

 **CAUTION**

Carry out maintenance after the parts have cooled down;

- Carry out the maintenance work after the heated area such as the muffler or the engine is fully cooled down.

If this instruction is ignored, there is a risk of getting burnt.

 **CAUTION**

Stop and cool down the engine before fueling or lubricating;

- Do not fill the fuel while the engine is running or machine is hot.

If this instruction is ignored, fuel can catch fire or lead to fatal injury with severe burns.



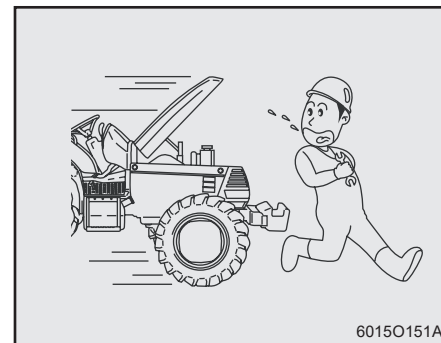
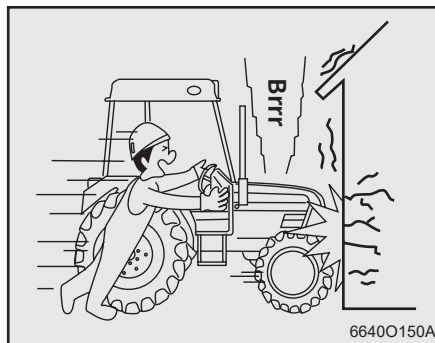

### ⚠ CAUTION

Be careful of high oil pressure;

- Make sure that the hydraulic coupling or the hose is not loose or damaged. Before separating the hydraulic coupling or the hose, eliminate the high pressure inside the hydraulic system by moving the control lever while engine is stopped.

If this instruction is ignored, the oil under high pressure may cause skin injury.

### ⚠ WARNING

Make sure that you are seated in the driver's seat with your seat belt fastened before starting engine;

- When starting the engine, make sure that you are seated in the driver's seat with your seat belt fastened and check the seat position and the safety of the tractor.

If this instruction is ignored, an unexpected accident may occur.

### ⚠ CAUTION

Stop the engine before maintenance;

- Stop the engine before maintenance such as checking, repairing or cleaning the machine.

If this instruction is ignored, there is a risk of injury.

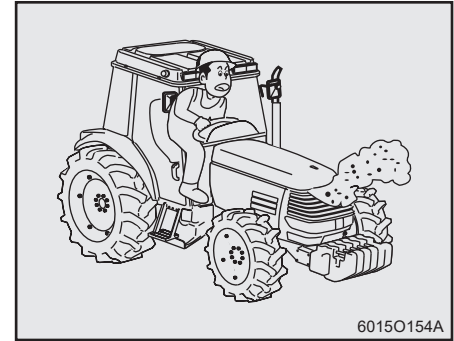
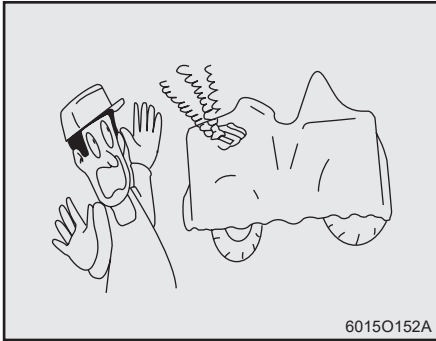

**! WARNING**

Put tractor rain cover on only after tractor has cooled down;

- Put tractor rain cover on only after parts such as the engine and muffler have cooled down.

If this instruction is ignored, there is a risk of fire.

**! WARNING**

Do not open the radiator cap when the radiator is hot;

- Never open the radiator cap when the radiator is heated.

If this instruction is ignored, hot water may spurt, causing burns or damage.

**! WARNING**

Remove dirt and debris from muffler and engine before operating;

- Clean if there is dust, debris or fuel on the engine or muffler before operating the machine every day.

If this instruction is ignored, there is a risk of fire.

## PRECAUTION FOR PROLONGED STORAGE

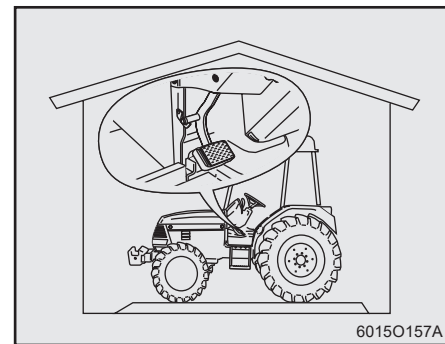
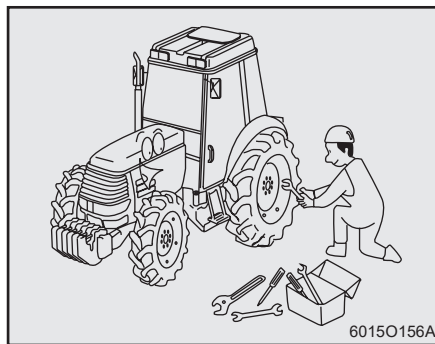
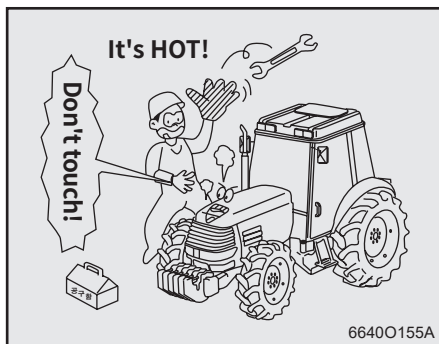

**⚠ CAUTION**

Be careful of hot muffler;

- During operation and right after the engine is turned off, the muffler is very hot. Avoid touching it.

If this instruction is ignored, you may get burnt.

**⚠ CAUTION**

After working, immediately repair if necessary;

- Immediately repair or replace the faulty parts.
  - Tighten the loose bolt and nut right away.

If this instruction is ignored, an unexpected accident may occur due to poor maintenance.

**⚠ CAUTION**

Disengage the clutch when storing the tractor for a long time;

- When storing the tractor for a long period of time, make sure to put the clutch pedal in the disengaging position.

If this instruction is ignored, the clutch disc can be stuck to the fly wheel after long period time.

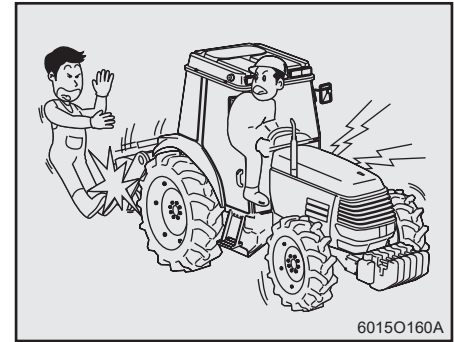
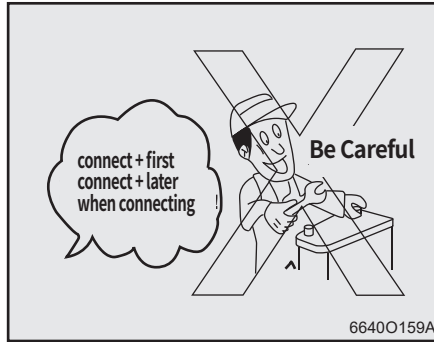
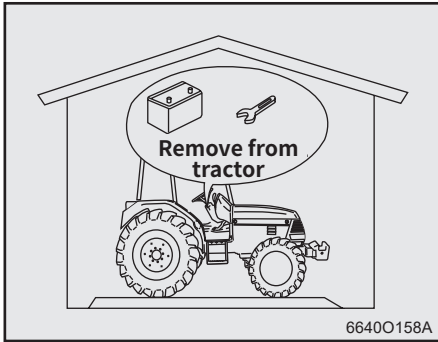

**⚠ WARNING**

Disconnect the Battery and the key when storing the tractor for a long period of time;

- When storing the tractor without use for a long period of time, park the machine on the leveled ground and clean each component, remove the battery and keep the key in a safe place.

If this instruction is ignored, battery power may be weakened and starting will be failed.

**⚠ CAUTION**

Observe correct procedures when installing or removing the battery;

- Connect the (+) terminal first when installing the battery, and disconnect the (-) terminal first when removing it.

If this instruction is ignored, there is a risk of burn or fire due to short circuit.

**⚠ WARNING**

Confirm that the implement is down on the ground when starting the engine;

- When starting the engine, confirm that the control lever is on "Lowest" position.

If this instruction is ignored, implement may come down suddenly and cause an injury.

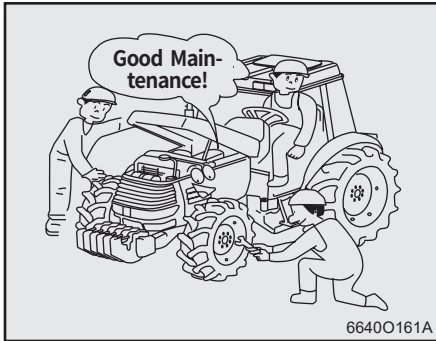

### ! WARNING

Maintenance periodically;

- After using tractor, visit your local dealer for maintenance, such as oil change and filters.
  - Contact the local dealer to discard the parts (battery, etc.) or waste materials.

If this instruction is ignored, there is a risk of accident due to poor maintenance.

## OTHER

### ! WARNING

Do not adjust or repair following components. Consult your local TYM dealer for these repair;

- Injection capacity and timing of the engine fuel injection pump.
- Correction and repair of hydraulic system (safety valve, hydraulic pump, brake valve, PST cylinder, SCV valve).

There is a risk of accident or injury or machinery breakdown. Remember it may cause the warranty cancellation.

If this instruction is ignored, consult your local TYM dealer for those repair and adjustment.

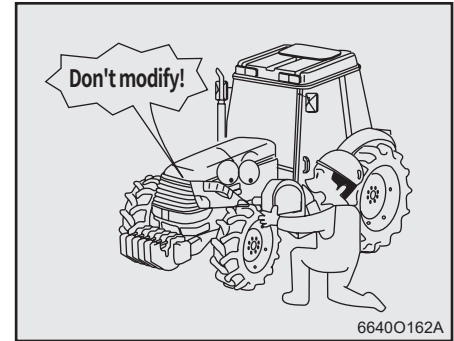

### ! CAUTION

Do not modify the tractor;

- Use only the genuine parts or other approved parts. Do not modify the tractor.

If this instruction is ignored, there is a risk of accident or injury or machinery breakdown. Remember it may cause the warranty cancellation.

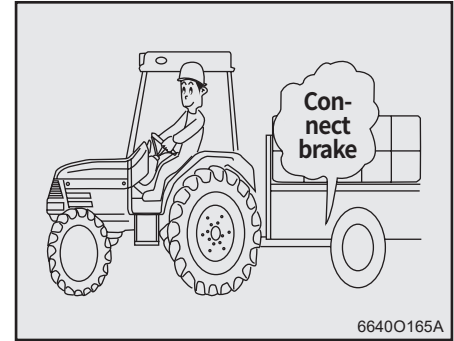
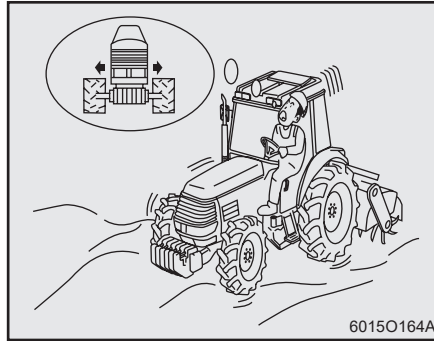
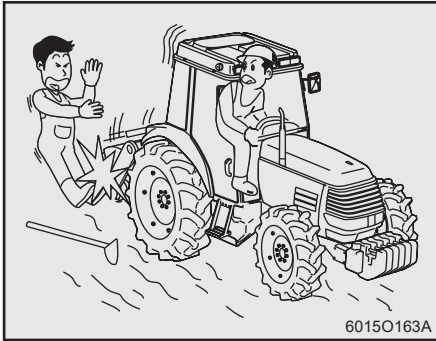

**⚠ WARNING**

Pay attention when turning with implement;

- Depending on implements, the overall length may become very long. Pay particular attention to people or objects nearby when making a turn.

If this instruction is ignored, there is a risk of person injury or a collision of the implement.

**⚠ WARNING**

Move wheels to widest setting (width between left and right tires) when working slope or when towing;

If this instruction is ignored, there is a risk of turning over.

**⚠ WARNING**

Use caution sign when towing a trailer;

- Link the brake of the trailer with the brake of the tractor. Do not shift gears when driving on a hill.

If this instruction is ignored, there is a risk of accident or injury.

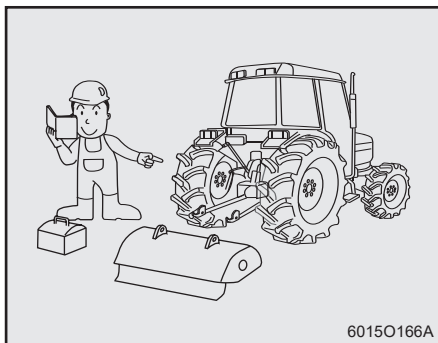

**! WARNING**

Follow the instruction manual when engaging an implement;

- When engaging an implement to the tractor, follow the instruction manual for the implement.

If this instruction is ignored, there is a risk of personal injury or damage to the tractor.

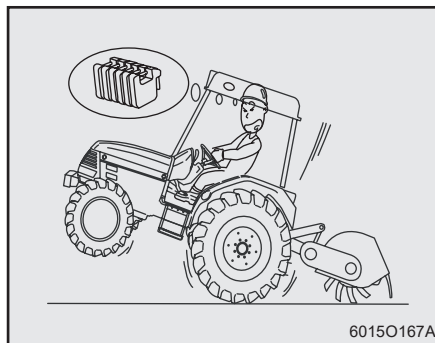

**! WARNING**

Balance a heavy implement with weights;

- When engaging a heavy implement, load the weights on the front of tractor to keep the balance of the tractor.

If this instruction is ignored, there is a risk of accident or injury due to loss of balance.

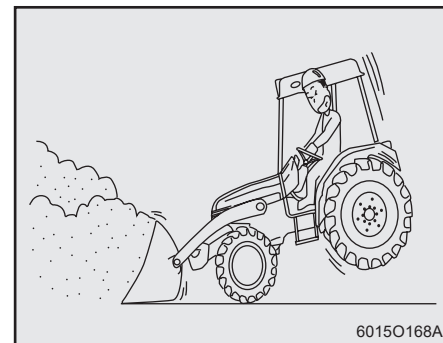

**! WARNING**

Pay attention to the balance between the front and rear side during the front-end-loader operation;

- During the front-end-loader operation, apply weights or implement to avoid losing balance between the front and the rear side of tractor.

If this instruction is ignored, there is a risk of overturning accident due to loss of balance.

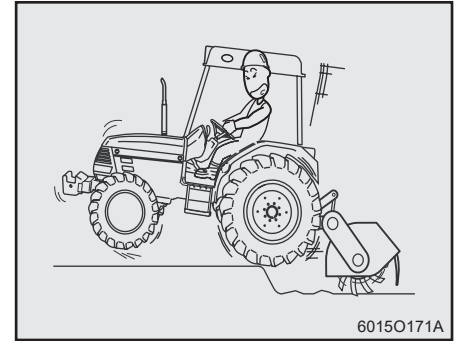
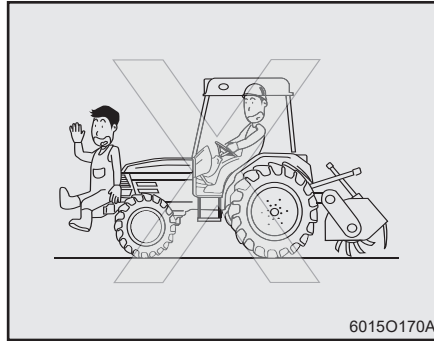
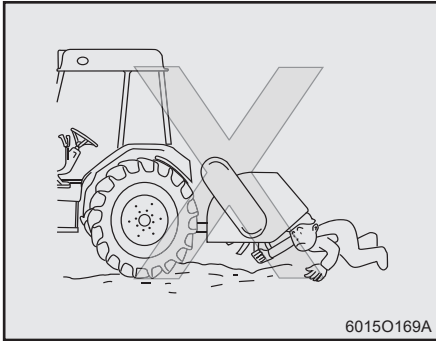

**⚠ WARNING**

Do not get under or put your feet under the implement;

- Do not get under or put your feet under the implement.

If this instruction is ignored, the implement unit may fall down and there is a risk of injury.

**⚠ WARNING**

Do not substitute balance weights with a person or anything else;

- Do not use a person or anything else in place of the balance weight. Use only genuine balance weight.

If this instruction is ignored, there is a risk of accident or injury.

**⚠ WARNING**

Be careful of unexpected movement when using the rotary tiller;

- When working with the rotary tiller, put the tiller slowly on soft or rocky ground. The tractor may be pushed in an unexpected direction by the rotating force of the tiller.

If this instruction is ignored, there is a risk of accident or injury.



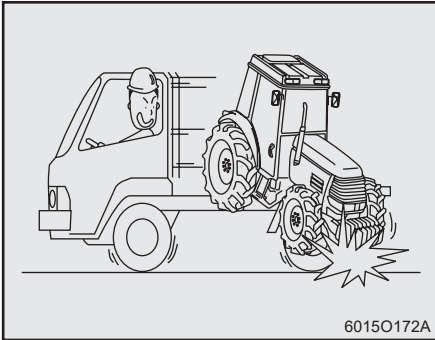

### WARNING

Properly secure tractor during transport;

- When transporting the tractor, apply the parking brake with gear engaged and fasten the tractor to the truck securely using ropes or belts with sufficient strength.

If this instruction is ignored, There is a risk of accident that the tractor may fall off the truck.

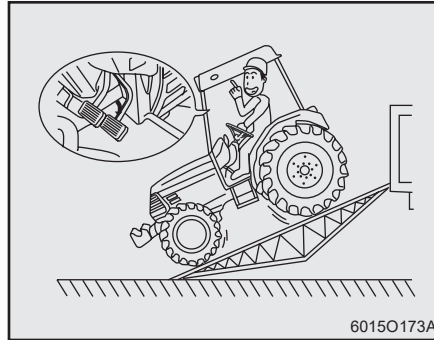

### DANGER

Interlock the brake pedals for both sides when loading or unloading the tractor;

- It is necessary to interlock the brake pedals for both sides when loading or unloading the tractor.

If this instruction is ignored, the tractor may overturn due to one-sided braking when the brake pedal is depressed in an emergency.

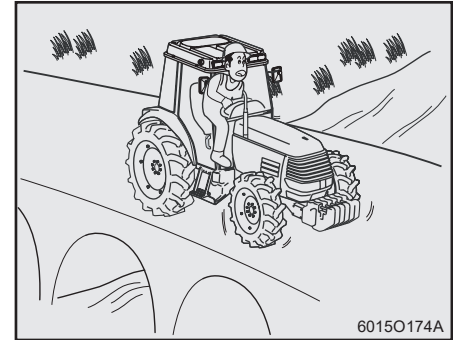

### WARNING

Release the differential gear lock when making a turn;

- Make sure to release the differential gear lock when making a turn.

If this instruction is ignored, the tractor may not turn to the intended direction and cause an accident.

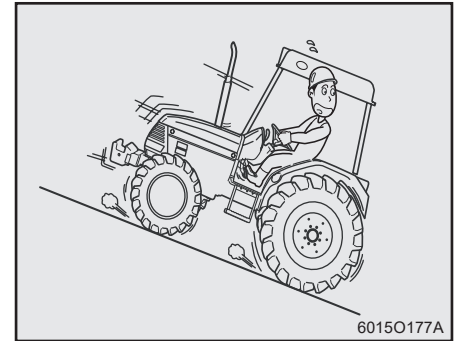
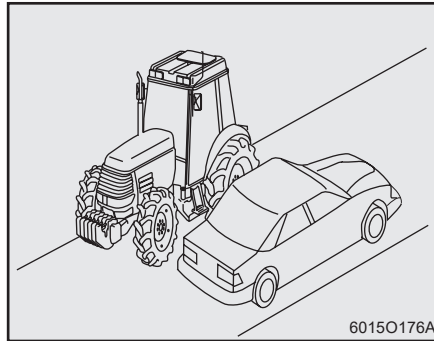
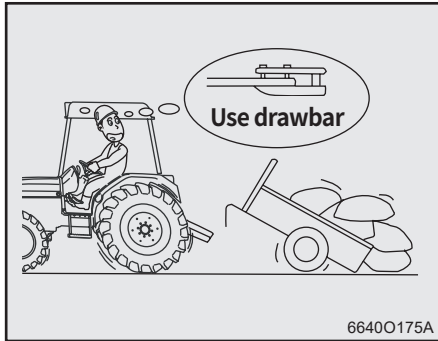

**! WARNING**

Use the drawbar when towing;

- Make sure to use the drawbar when towing. Never tow anything with the top link or the lower links.

If this instruction is ignored, the tractor may turn over.

**! WARNING**

Pay attention to the shoulder of the road;

- When moving along the unpaved road with ditches or slanted sides, pay attention to the road shoulder.

If this instruction is ignored, there is a risk of falling over.

**! WARNING**

Be careful when driving on a hill;

- Be careful when driving on a hill. Do not disengage the clutch on the hill. Do not shift the main shift lever, range shift lever, or shuttle lever in [neutral] on the hill.

If this instruction is ignored, the tractor may roll backwards or fall causing accident or injury.

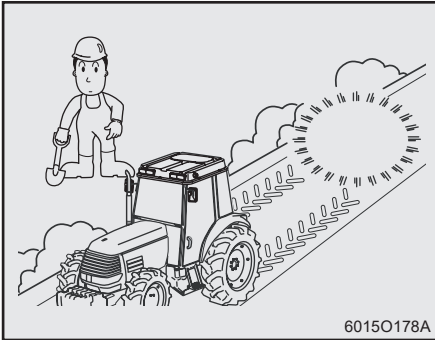

**! WARNING**

Turn off engine in a level area when leaving the tractor;

- When leaving the tractor, park the tractor on a level and safe area, turn off the engine, and apply the parking brake. Also, lower the implement on the ground.

If this instruction is ignored, the tractor may move and cause an accident.

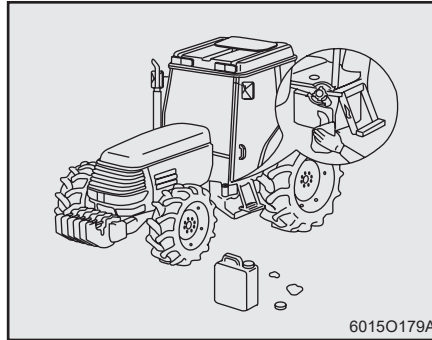

**! WARNING**

Remove spilled excess fuel after closing the fuel cap;

- After filling the fuel tank, close the fuel filler cap completely and wipe off the excess fuel thoroughly.

If this instruction is ignored, there is a risk of fire.

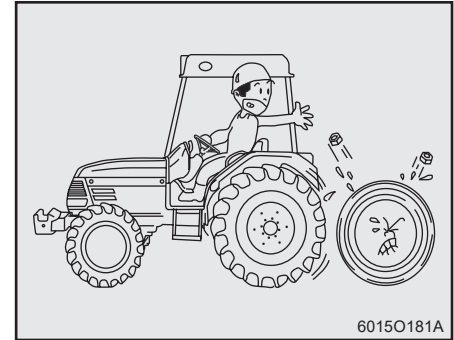

**! WARNING**

Be aware of the PTO RPM requirements for the implements;

If this instruction is ignored, there is a risk of accident or injury.

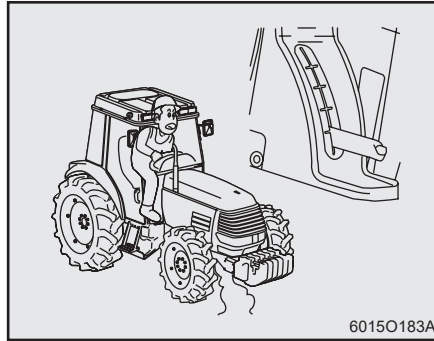
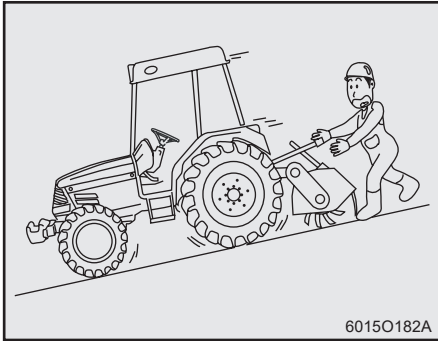

**⚠ WARNING**

Only engage or disengage implements on flat, level area:

- Engage or disengage the implement on a flat and safe place. Supply proper lighting at all times and especially night.

[Otherwise]

There is a danger of accident.

**⚠ CAUTION**

Engage the parking brake during warming up the engine;

If this instruction is ignored, the tractor may move and cause an accident or injury.

## DECAL MOUNTING LOCATION





## DECAL

(1) No.: TA00036924A



(2) No.: TZE5130000C4



(3) No.: TZE5180000C4



(4) No.: TA00040603A [MEC. Model]

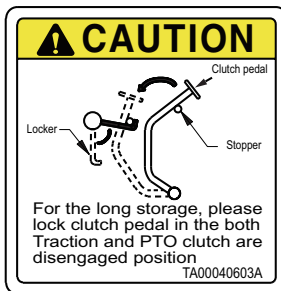

(5) No.: TZE4190000C4

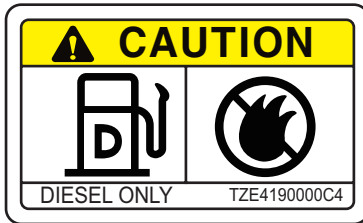

(6) No.: TZE5110000B4



(7) No.: TZE5160000B3

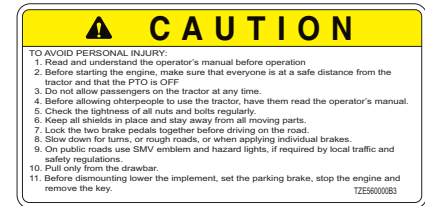

(8) No.: TZE5170000B3

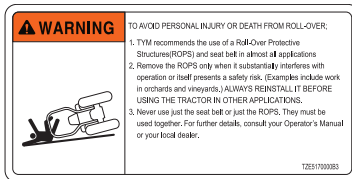

(9) No.: TZE5140000B3

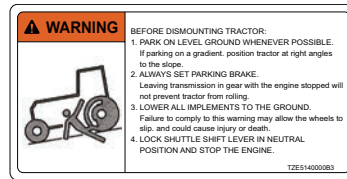

(10) No.: TZE5120000B4





(11) No.: TA00015596B

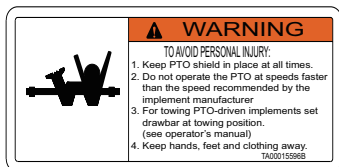

**⚠ WARNING**

TO AVOID PERSONAL INJURY:

1. Keep PTO shield in place at all times.
2. Do not operate the PTO at speeds faster than the speed recommended by the implement manufacturer
3. For towing PTO-driven implements set drawbar at towing position. (see operator's manual)
4. Keep hands, feet and clothing away.

TA00015596B

(12) No.: TZE4100000B4 [MEC. Model]

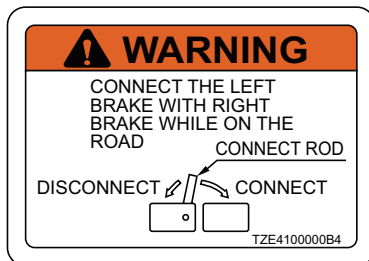

**⚠ WARNING**

CONNECT THE LEFT BRAKE WITH RIGHT BRAKE WHILE ON THE ROAD

DISCONNECT      CONNECT ROD

TZE4100000B4

(13) No.: TZE5770000B3

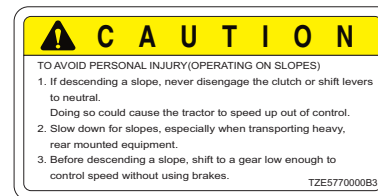

**⚠ CAUTION**

TO AVOID PERSONAL INJURY (OPERATING ON SLOPES)

1. If descending a slope, never disengage the clutch or shift levers to neutral. Doing so could cause the tractor to speed up out of control.
2. Slow down for slopes, especially when transporting heavy, rear mounted equipment.
3. Before descending a slope, shift to a gear low enough to control speed without using brakes.

TZE5770000B3

(14) No.: NTE5150000C4



**⚠ WARNING**

Use seat belt

NTE5150000C4

(15) No.: NTE5210000C4

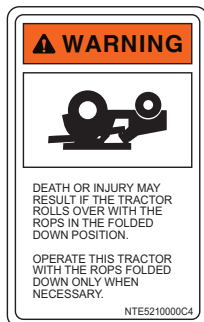

**⚠ WARNING**

DEATH OR INJURY MAY RESULT IF THE TRACTOR ROLLS OVER WITH THE ROPS IN THE FOLDED DOWN POSITION.

OPERATE THIS TRACTOR WITH THE ROPS FOLDED DOWN ONLY WHEN NECESSARY.

NTE5210000C4

(16) No.: NTE5220000C4

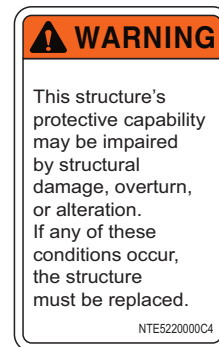

**⚠ WARNING**

This structure's protective capability may be impaired by structural damage, overturn, or alteration. If any of these conditions occur, the structure must be replaced.

NTE5220000C4

## CAUTIONS FOR DECAL MAINTENANCE

Safety decals are attached to the tractor for safe operation. Make sure to follow the instruction on the decals as well as the following instruction:



### CAUTION

- Keep the decals clean and intact. If any decal is dirty, wash it with soap and dry with a soft cloth.
- Never use a solvent such as thinner or acetone, since it can ruin the decals.
- Do not spray high-pressure water directly onto the decal. The decal may fall off the tractor.

### ⊕ IMPORTANT

- If a decal is damaged or lost, contact your local TYM dealer immediately to install a new decal.
- Make sure to attach the decal in the correct position cleanly without bubbles after cleaning its mounting surface.
- If a decal is attached to a component to be replaced, replace the decal as well.

## 2. REGARDING WARRANTY SUPPORT

<b>REGARDING WARRANTY CERTIFICATE .....</b>	<b>2-2</b>
<b>REGARDING AFTER-SALES SERVICE .....</b>	<b>2-2</b>
VEHICLE IDENTIFICATION NUMBER (VIN) .....	2-2
<b>REGARDING SUPPLYING SERVICE PARTS .....</b>	<b>2-3</b>
<b>REGARDING GENUINE PARTS AND FLUID .....</b>	<b>2-3</b>

## REGARDING WARRANTY CERTIFICATE

**⚠ WARNING**

Do not modify the machine. If it is damaged by unapproved modification and misuse against description of manual, it will not be covered under warranty.

## REGARDING AFTER-SALES SERVICE VEHICLE IDENTIFICATION NUMBER (VIN) PRODUCTION SERIAL NUMBER

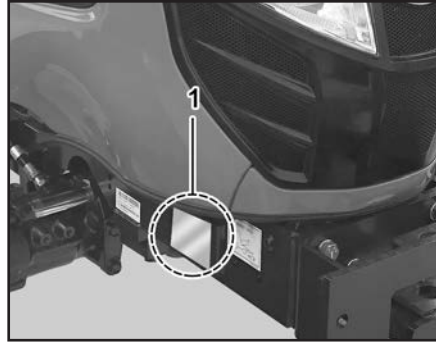

*(1) Model And Production Serial Number*

The manufacturer's serial number is marked on the serial number decal which is attached to the front right side of the front axle bracket.

## ENGINE SERIAL NUMBER

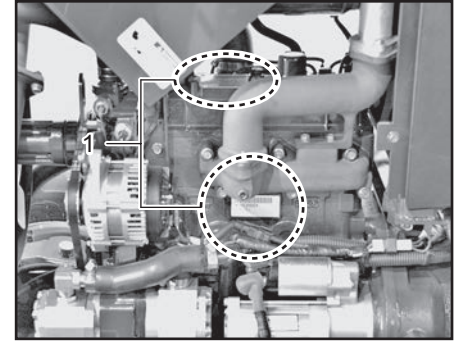

*(1) Engine Serial Number*

The engine number is stamped on the cylinder block and is specified on the decal which is attached to the cylinder block on the left side of the engine. Also, the decal indicating the engine model and standards is attached on the top of the engine cylinder head cover.

## REGARDING SUPPLYING SERVICE PARTS

### ► REGARDING AFTER-SALES SERVICE

If you have a problem on your machine, refer to "Troubleshooting" of chapter 7 to check by yourself. Or contact immediately to authorized **TYM** dealer nearby.

### ► BE PREPARE FOR THE FOLLOWING QUESTION BEFORE CALLING

- Model and product serial number
- In case of engine failure, engine serial number
- Working conditions (What kind of job and how fast)
- Run hour of machine
- Describe the problem in detail as possible

We supply the service parts in accordance with the separated quality assurance regulation.

Consult your local dealer for availability and pricing.

## REGARDING GENUINE PARTS AND FLUID

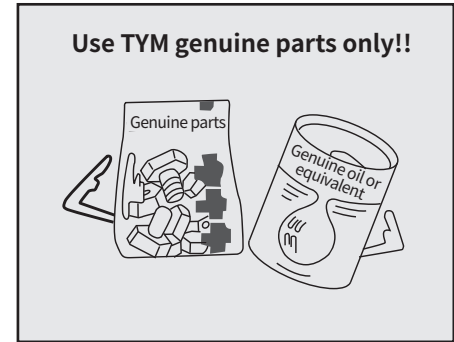

The **TYM** genuine parts and fluid are passed severe durability and performance test. Please use **TYM** genuine parts for your safety.



# 3. SPECIFICATIONS

MAJOR SPECIFICATIONS ..... 3-2  
DRIVING SPEED ..... 3-4

## MAJOR SPECIFICATIONS

Specification		F25R(H) F25Rn(hn)	F36R(H) F36Rn(hn)	F42R(H) F42Rn(hn)	F50R(H) F50Rn(hn)
PTO Power kW (ps)		15.7 (21)	22.5 (30)	26.8 (36)	30.7 (40)
Engine	Model	A1700N6	A1700N2	A2000N2	A2300N2
	Type	Vertical, 4-stroke, water-cooled diesel engine			
	No. of cylinders	3		4	
	Bore x Stroke mm (in.)	88 × 94 (3.46 × 3.70)			
	Displacement cc	1,715		2,084	2,287
	Horsepower kW (ps)	18 (24)	26 (35)	31 (42)	36 (48)
	Revolution rpm	2,100	2,600		
	Max. torque kgf-m/rpm	9.5 / 1600	11.2 / 1,700	13.2 / 1,600	15.8 / 1,650
	Battery V	12			
	Fuel	Diesel fuel			
Capacity	Fuel tank ℓ (u.s. gal)	27 (7.13)			
	Engine crankcase ℓ (u.s. gal)	4.3 (1.14)			
	Coolant ℓ (u.s. gal)	5.0 (1.32)		5.5 (1.45)	
	Transmission case ℓ (u.s. gal)	Manual: 34 (8.98) / HST: 37 (9.77)			
Dimensions	Overall length mm (in.)	3,071 (120.9) (W/O Front Weight)			
	Overall width mm (in.)	R(H) : 1,451 (57.13) / Rn(hn) : 1,348 (53.07)			
	Overall height mm (in.)	2,471 (97.3)			

※Dimensions and weights are based on 8-16 / 12.4-24.



Specification		F25R(H) F25Rn(hn)	F36R(H) F36Rn(hn)	F42R(H) F42Rn(hn)	F50R(H) F50Rn(hn)
Dimensions	Wheel base	mm (in.) 1,670 (65.7)			
	Ground clearance	mm (in.) 359 (14.1)			
	Tread	Front wheel	mm (in.) R(H) : 1,204 (47.4) / Rn(hn) : 1,104 (43.5)		
		Rear wheel	mm (in.) R(H) : 1,160 (45.7) / Rn(hn) : 1,024 (40.3)		
Weight	kg	R(n) : 1,356 RH(n) : 1,347	R(n) : 1,444 RH(n) : 1,435	R(n) : 1,487 RH(n) : 1,478	
Driving system	Tire (standard)	Front wheel	8.0-16 4PR		
		Rear wheel	12.4-24 6PR		
	Steering system	Electro-hydraulic power steering			
	Transmission	Synchro Mesh, Synchro Shuttle			
	Brake	Wet multi disc			
Hydraulic system	Hydraulic control system	Position/Draft			
	Pump flow	ℓ/min	43.5	46.8	54.2
	3-point hitch	CAT1			
	Max. lift	kg	1,500		
PTO	PTO shaft specification	Ø 35 mm - 6 splines			
	Revolution	rpm	560 (1 gears)	560/780 (2 gears)	

※ Dimensions and weights are based on 8-16 / 12.4-24.

## DRIVING SPEED

※ The tractor's speed is changed by the condition of the tires and road surface.

※ To ensure safety, drive at a proper speed.

### [MEC. MODEL]

Engine speed: F25R(n) - 2,100 rpm

F36R(n)/F42R(n)/F50R(n) - 2,600 rpm

Tire rolling radius: 532 mm (Rear 12.4-24)

km/h (mph)

RANGE		A				B				C			
		1	2	3	4	1	2	3	4	1	2	3	4
F25R(n)	FORWARD	1.1 (0.68)	1.6 (0.99)	2.1 (1.30)	2.5 (1.54)	2.9 (1.80)	4.1 (2.54)	5.4 (3.35)	6.3 (3.90)	8.6 (5.33)	12.1 (7.50)	16.0 (9.90)	18.7 (11.60)
	REVERSE	1.1 (0.68)	1.6 (0.99)	2.0 (1.23)	2.4 (1.47)	2.8 (1.70)	3.9 (2.41)	5.2 (3.22)	6.1 (3.77)	8.3 (5.14)	11.7 (7.25)	15.4 (9.52)	18.0 (11.1)
F36R(n) F42R(n) F50R(n)	FORWARD	1.4 (0.87)	2.0 (1.24)	2.6 (1.61)	3.1 (1.93)	3.7 (2.30)	5.1 (3.17)	6.7 (4.16)	8.1 (5.03)	10.7 (6.64)	15.1 (9.38)	19.6 (12.17)	23.9 (14.84)
	REVERSE	1.3 (0.81)	1.8 (1.12)	2.4 (1.49)	2.9 (1.80)	3.6 (2.24)	4.9 (3.04)	6.5 (4.04)	8.0 (4.97)	10.3 (6.40)	14.1 (8.76)	18.9 (11.74)	23.0 (14.28)

- ※ The tractor's speed is changed by the condition of the tires and road surface.
- ※ To ensure safety, drive at a proper speed.

**[HST MODEL]**

Engine speed: F25H(n) - 2,100 rpm  
 F36H(n)/F42H(n)/F50H(n) - 2,600 rpm

Tire rolling radius: 532 mm (Rear 12.4-24)

km/h (mph)

RANGE		A	B	C
F25H(n)	FORWARD	4.9 (3.04)	12.6 (7.8)	20.9 (12.9)
	REVERSE			
F36H(n) F42H(n) F50H(n)	FORWARD	6.1 (3.79)	15.6 (9.69)	25.9 (16.0)
	REVERSE			

# MEMO

A series of horizontal dotted lines for writing.

# 4. OPERATION DESCRIPTION

<b>EXTERIOR VIEW .....</b>	<b>4-2</b>	<b>CONTROLS 1 .....</b>	<b>4-14</b>
<b>SWITCHES AND LEVERS .....</b>	<b>4-3</b>	FOOT CONTROLS .....	4-14
MAIN SWITCH .....	4-5	CLUTCH PEDAL .....	4-15
HAZARD WARNING FLASHER SWITCH .....	4-5	BRAKE PEDALS (LEFT/RIGHT).....	4-16
TURN SIGNAL/LAMP SWITCH .....	4-6	FOOT THROTTLE PEDAL.....	4-16
SHUTTLE SHIFT LEVER[MEC. MODEL] .....	4-6	<b>CONTROLS 2 .....</b>	<b>4-17</b>
CRUISE CONTROL SWITCH[HST MODEL].....	4-7	HAND CONTROLS.....	4-17
DPF REGENERATION SWITCH.....	4-8	MAIN SHIFT LEVER.....	4-17
<b>INSTRUMENT CLUSTER.....</b>	<b>4-9</b>	RANGE SHIFT LEVER .....	4-18
PTO INDICATOR.....	4-10	HAND THROTTLE LEVER.....	4-18
LEFT/RIGHT TURN SIGNAL INDICATOR .....	4-10	PTO ON/OFF SWITCH.....	4-18
HIGH BEAM INDICATOR .....	4-10	OUTSIDE PTO ON/OFF SWITCH .....	4-19
PARKING BRAKE & BRAKE INDICATOR .....	4-11	DIFFERENTIAL LOCK PEDAL .....	4-19
ENGINE OIL PRESSURE WARNING LAMP .....	4-11	PARKING BRAKE.....	4-20
BATTERY CHARGE WARNING LAMP .....	4-12		
PREHEAT INDICATOR.....	4-12		
FUEL GAUGE.....	4-12		
TACHOMETER/HOUR METER .....	4-13		
COOLANT TEMPERATURE GAUGE .....	4-13		

## EXTERIOR VIEW

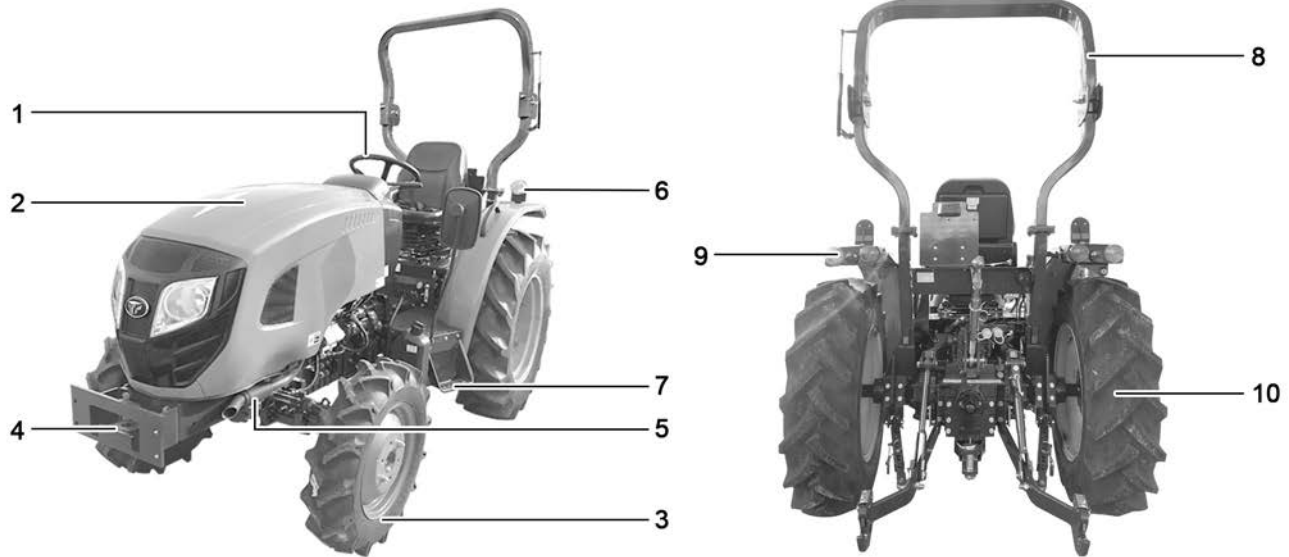

- (1) Steering Wheel
- (2) Bonnet
- (3) Front Tire

- (4) Front Weight Hitch
- (5) Muffler
- (6) Combination Lamp

- (7) Step
- (8) Safety Frame
- (9) Combination Lamp(REAR)

- (10) Rear Tire

## SWITCHES AND LEVERS



4

- A: Steering Wheel (Handle)
- B: Ignition Switch
- C: Hazard Warning Flasher Switch
- D: PTO Switch
- E: Cruise Switch (only forward)]
- F: Instrument Cluster
- G: Turn Signal / Lamp switch
- H: DPF Regeneration Switch

※ Refer to the relevant content for further detailed information

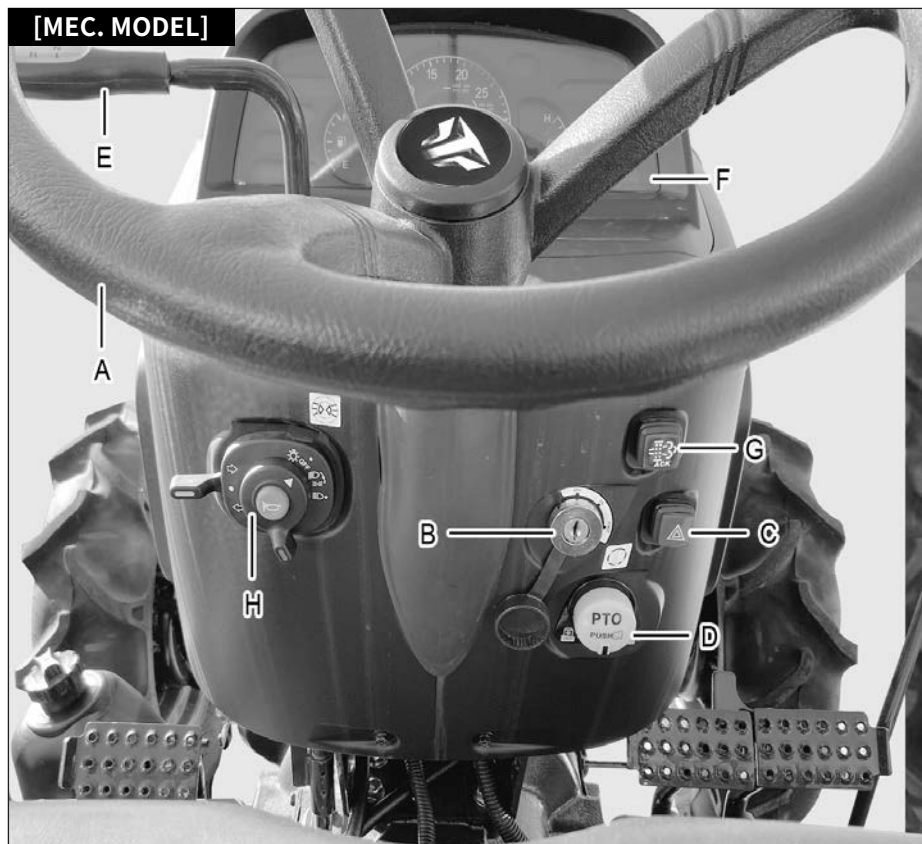

- A: Steering Wheel (Handle)
- B: Ignition Switch
- C: Hazard Warning Flasher Switch
- D: PTO Switch
- E: Shuttle Shift Lever
- F: Instrument Cluster
- G: DPF Regeneration Switch
- H: Turn Signal / Lamp switch

※ Refer to the relevant content for further detailed information



## MAIN SWITCH

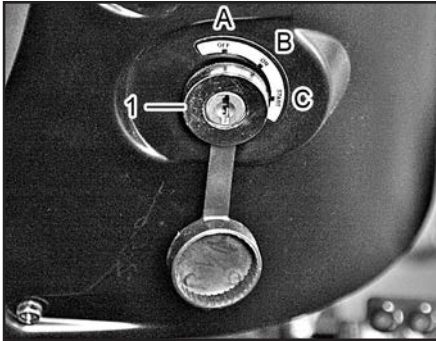

(1) Main Switch      (A) OFF  
(B) ON                (C) START

The main switch is used to start or stop the engine.

OFF: The engine is stopped, and current ends at the ignition switch.

ON: Electric current flows to all switches in the electrical system.

START: When the start motor is engaged, the engine will start. When the engine is started, release the key. The key will return to the "ON" position automatically and the engine will keep running.

### CAUTION

- To start the engine, put the shuttle shift lever to the "Neutral" position to release the safety start system.

## HAZARD WARNING FLASHER SWITCH



(1) Hazard Warning Flasher Switch

Press the hazard flasher warning switch in emergency to warn other vehicles in order to prevent an accident.

Pressing this switch blinks all turn signal lamps regardless of the position of the main switch. Pressing it again disables the flasher function.

**⚠ CAUTION**

- Prolonged operation can consume electricity excessively. Therefore, use it only in emergency. Use it only when necessary as it can discharge the battery and obstruct other drivers' view.

## TURN SIGNAL/LAMP SWITCH

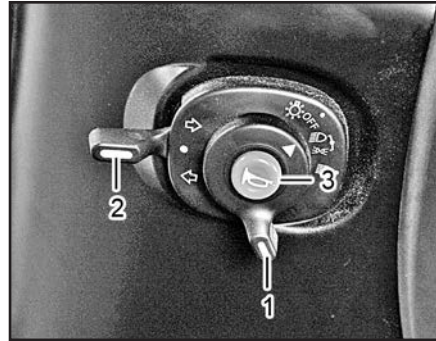

(1) Lamp Switch  
(2) Turn Signal Lamp Knob (3) Horn Button

Turning the lamp switch clockwise to the first notch turns on the tail lamps and instrument cluster. Turning it further turns on the high/low beam.

Push up the turn signal lamp knob to turn on the right turn signal lamp and press down the knob to turn on the left turn signal lamp. To sound the horn, press the horn button in center of the switch.

## SHUTTLE SHIFT LEVER [MEC. MODEL]

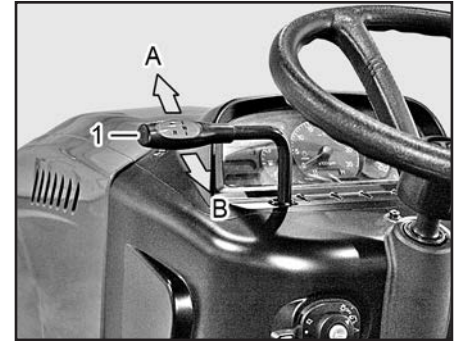

(1) Shuttle Shift Lever  
(A) Forward (B) Reverse

This is used to drive the tractor forward or backward. Shift the lever with the clutch pedal and brake pedal depressed to maximum.

## CRUISE CONTROL SWITCH [HST MODEL]

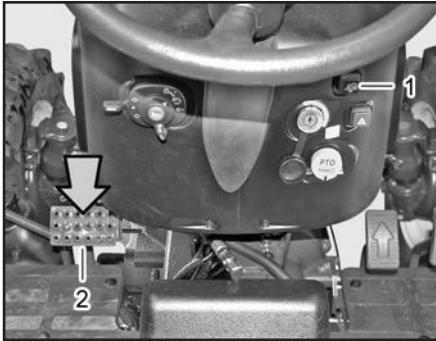

1. When the machine has reached the desired speed, press cruise control switch to "ON" Release the HST pedal and the machine will operate at the selected speed.
2. When applying full pressure to the Brake pedals, the cruise control will deactivated and it will be necessary to reset the cruise control to the desired speed.
3. When applying light pressure to the Brake pedals, the machine's ground speed will be reduced until the Brake

pedals released. At that point the machine will continue at the previous setting.

4. To reset the desired speed, you should turn off the cruise control switch then increase machine speed to reach the desired speed push cruise switch to on.

### CAUTION

- When stop the machine cruise control keep machine stop status.
- Make sure connecting the both Brake pedals when use cruise control function.

#### [Otherwise]

There is a risk abrupt turning or overturning due to onesided Braking when the Brake pedal is depressed.

## DPF REGENERATION SWITCH



*(1) DPF Regeneration Switch*

Holding the button down for more than 3 seconds initiates regeneration; the lamp turns off in 30 minutes when automatic regeneration is complete.

The DPF (diesel particulate filter) collects soot contained in the engine exhaust and reduces exhaust smoke. The soot collected in the filter must be burned periodically to prevent the filter from clogging and to ensure that the filter can continue collecting soot. The DPF is regenerated by increasing the back pressure in the engine and raising the temperature of the exhaust.

## INSTRUMENT CLUSTER

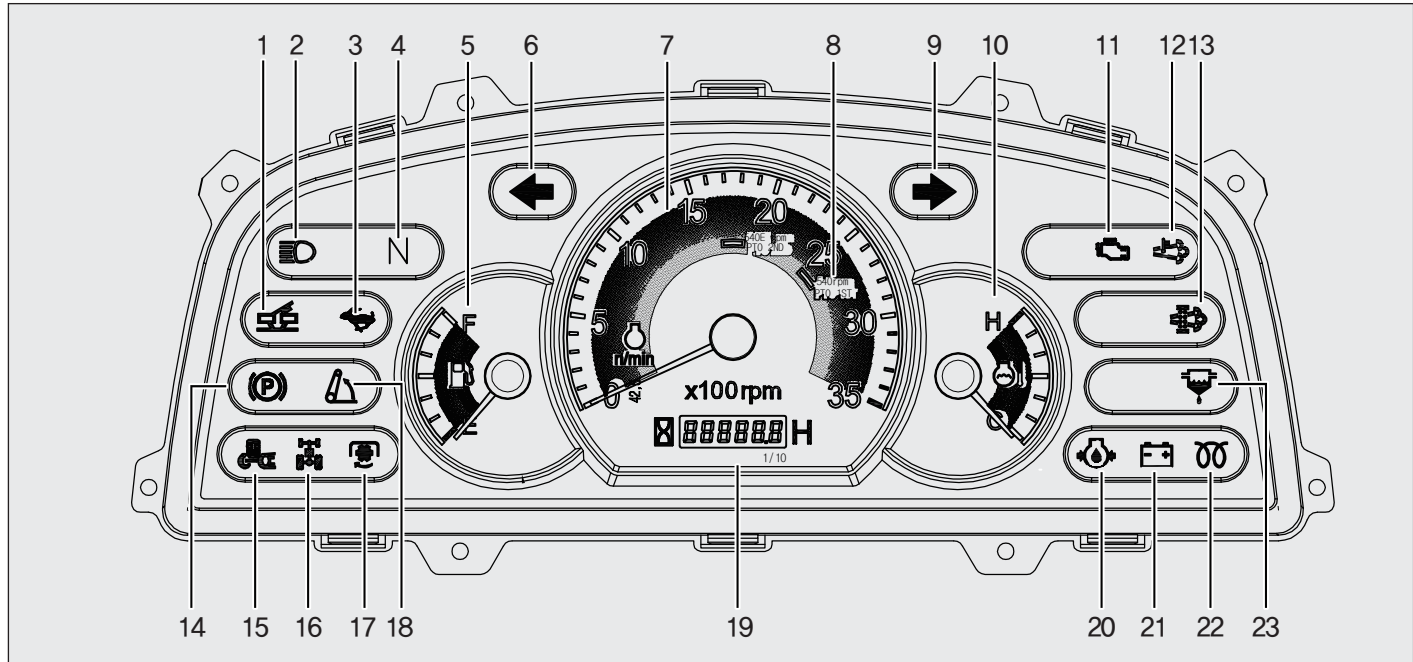

- |                           |                                |                                      |  |
|---------------------------|--------------------------------|--------------------------------------|--|
| (1) Brake Relaser         | (7) Tachometer                 | (13) DPF Indicator                   | (19) Hour Meter                          |
| (2) Upper Beam Indicator  | (8) PTO Rotating Position      | (14) Parking Brake (Brake) Indicator | (20) Engine Hydraulic Pressure Indicator |
| (3) High Speed            | (9) Turn Signal Indicator      | (15) QT Indicator                    | (21) Charge Warning Lamp                 |
| (4) Neutral               | (10) Coolant Temperature Gauge | (16) 4WD Indicator                   | (22) Preheat Indicator                   |
| (5) Fuel Gauge            | (11) DPF Fail Indicator        | (17) PTO Indicator                   | (23) Water Separator Indicator           |
| (6) Turn Signal Indicator | (12) EGT Indicator             | (18) Lift Indicator                  |  |

### PTO INDICATOR

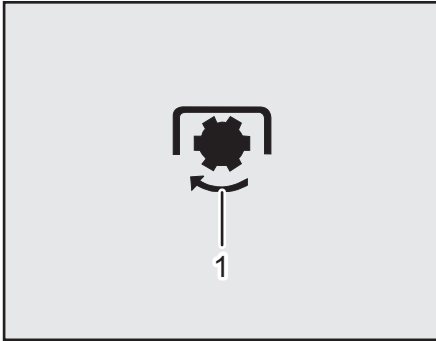

*(1) PTO Indicator*

This comes on when the PTO clutch switch is in the "IND" or "LINK" position.

### LEFT/RIGHT TURN SIGNAL INDICATOR

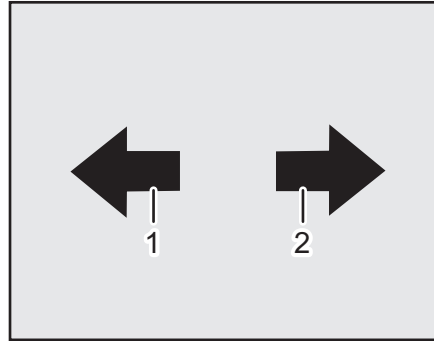

*(1) Left Turn Signal Indicator  
(2) Right Turn Signal Indicator*

This indicates the condition when operating one of the turn signal lamps for the desired turning direction.

### HIGH BEAM INDICATOR

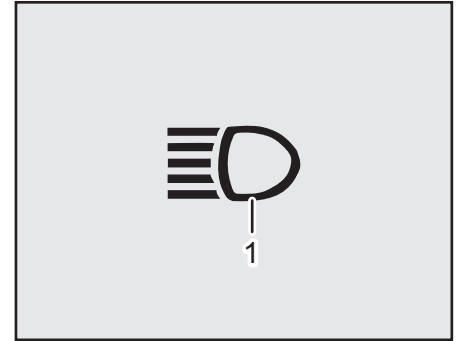

*(1) High Beam Indicator*

It indicates the high beam. Select the low beam for driving on a road.

## PARKING BRAKE & BRAKE INDICATOR

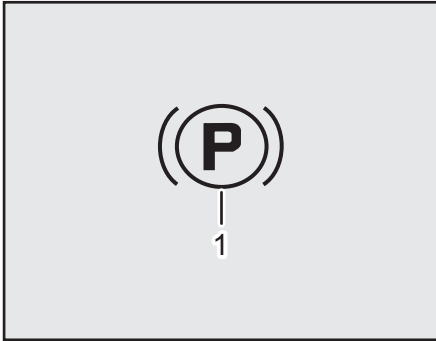

(1) Parking Brake (Brake) Indicator

This comes on when the parking brake is applied or the brake pedal is depressed. [US] This comes on when the parking brake is applied only. [EU] If the parking brake is applied, release the parking brake lever before driving. However, the lamp on the right side does not come on if only one side brake is released.

## ENGINE OIL PRESSURE WARNING LAMP

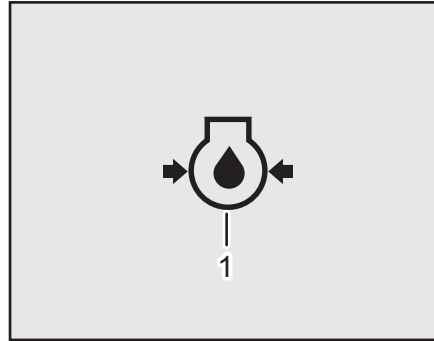

(1) Engine Oil Pressure Warning Lamp

When setting the main switch into the ON position while the ambient temperature is about 5°C, this indicator comes on to indicate the heater is energized. After the indicator goes off (automatically), turning the switch to the START position can start the engine. The illumination duration of the thermostat pilot lamp varies by the current applying duration of the heater according to the coolant temperature.

### NOTE

- Coolant temperature over 5°C: 1 sec. or shorter / Less than 5°C: 3 - 30 seconds

### BATTERY CHARGE WARNING LAMP

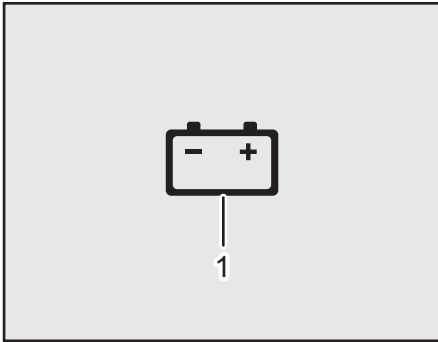

(1) Battery Charge Warning Lamp

The battery charge warning lamp is turned on when the ignition switch is initially turned to the "ON" position before starting the engine but turned off after starting the engine. If this lamp comes on while driving, the charging system is malfunctioning. In this case, check the fan belt or ask your local dealer for further inspection if necessary.

### PREHEAT INDICATOR

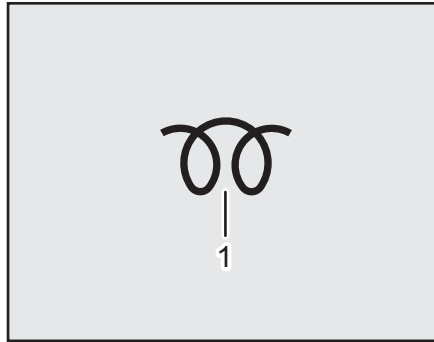

(1) Preheat Indicator

The 4WD indicator comes on when the 4WD lever is placed in "ON" position.

### FUEL GAUGE

This indicates the remaining fuel level. Immediately fill the fuel tank if the needle reads the red area.



## TACHOMETER/HOUR METER

The tachometer indicates the engine rpm and the hour meter indicates the total run hour of the tractor.

## COOLANT TEMPERATURE GAUGE

This coolant temperature gauge indicates the engine coolant temperature after the ignition switch is turned to the "ON" position. If the needle reads the red area, immediately stop working and then inspect the tractor.

## CONTROLS 1 FOOT CONTROLS

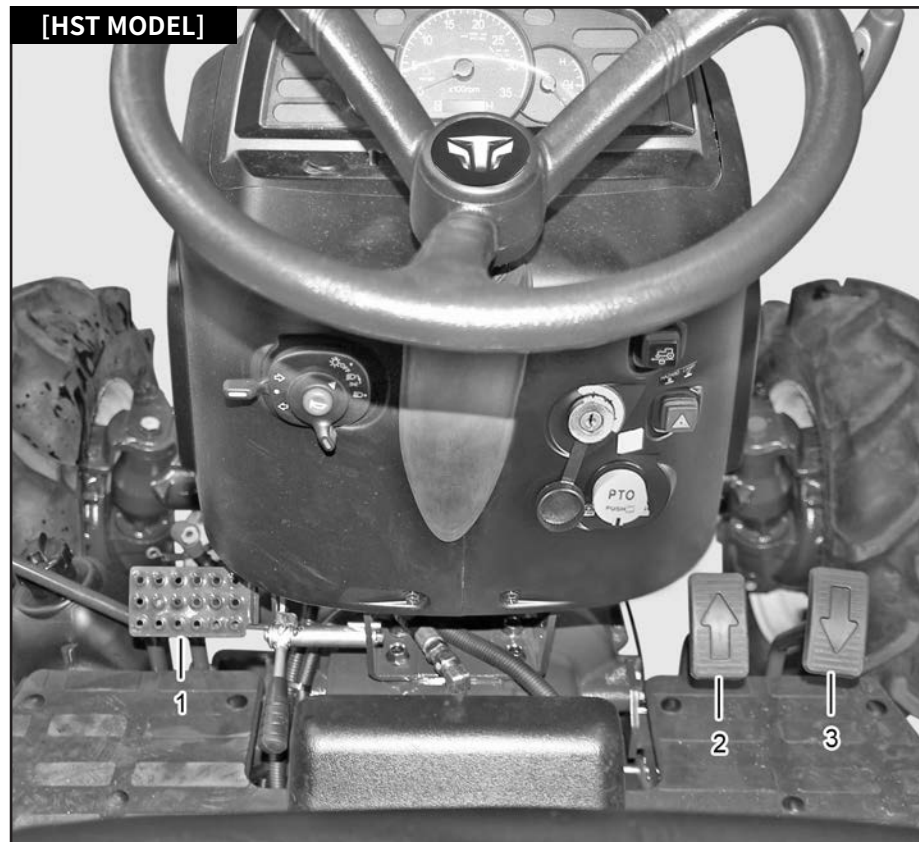

- (1) Brake Pedal
- (2) Forward Pedal
- (3) Backward Pedal

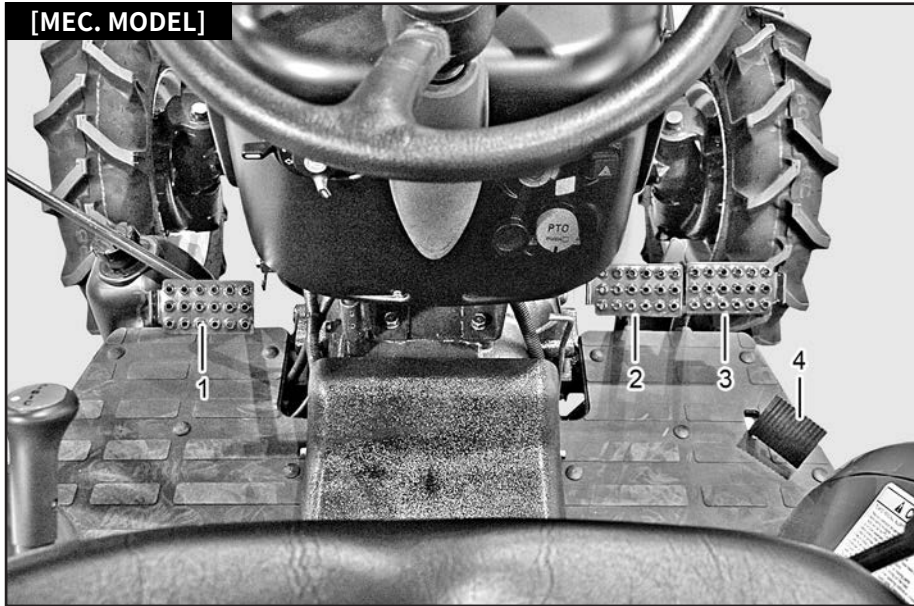

(1) Clutch Pedal  
(2) Left Brake Pedal

(3) Right Brake Pedal  
(4) Foot Throttle Pedal

## CLUTCH PEDAL

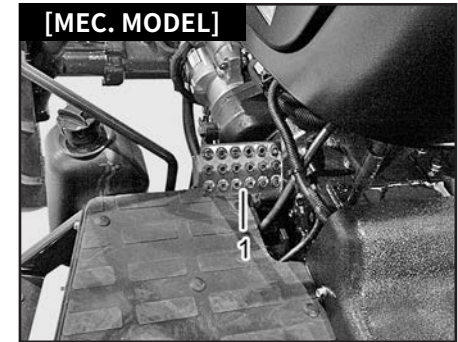

(1) Clutch Pedal

If the clutch pedal is depressed, driving power is stopped supplying. When the clutch pedal is depressed, the main/range shift lever can be operated. To start off smoothly, release the clutch pedal slowly.

## BRAKE PEDALS (LEFT/RIGHT)

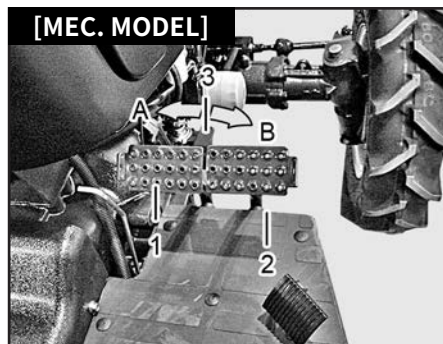

(1) Left Brake Pedal (2) Right Brake Pedal  
 (3) Link Bracket  
 (A) Release (B) Engage

Each brake pedal is activated independently. To make a sharp turn, depress one of the brake pedals on the turning direction to brake the rear wheel on the same side.

Make sure to interlock the brake pedals with the link bracket before driving on a public road.

### **WARNING**

- Make sure to interlock the left and right brake pedals with the link bracket while driving for travel. If this instruction is ignored, there is a risk of an accident such as roll-over due to unintended movement.

## FOOT THROTTLE PEDAL

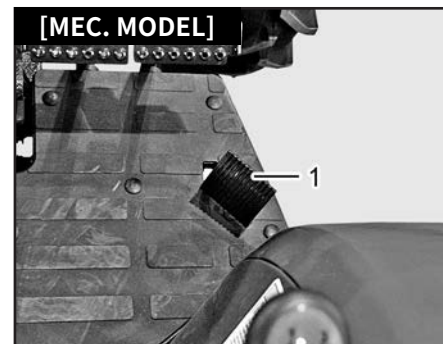

(1) Foot Throttle Pedal

The foot throttle pedal and the hand throttle lever are separated. If the pedal is depressed, the engine rpm becomes faster. While the pedal is released, the engine is idling.

To speed up during driving, use this pedal.

## CONTROLS 2

### HAND CONTROLS

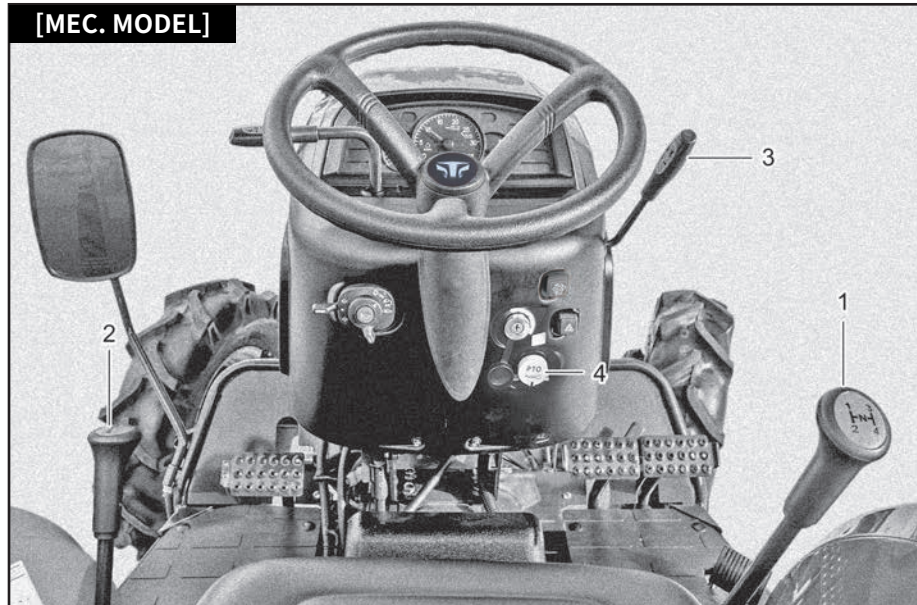

(1) Main Shift Lever  
(2) Range Shift Lever

(3) Hand Throttle Lever  
(4) PTO ON/OFF Switch

## MAIN SHIFT LEVER

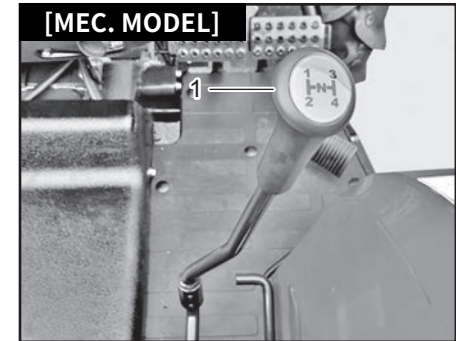

(1) Main Shift Lever

Four speeds can be selected by moving this main shift lever in “H” shaped path.

You can shift this lever from the 1st to 4th gears even when the tractor is moving by disengaging the clutch during driving as these gears are synchromesh type gears.

## RANGE SHIFT LEVER





(1) Range Shift Lever

3 speeds can be selected by the range shift lever. Therefore, in total, 12 forward driving speeds and 12 reverse driving speeds are provided by combination of the main shift lever and range shift lever.

Make sure to operate the lever while the tractor is stationary. Shift the lever with the clutch pedal firmly depressed.

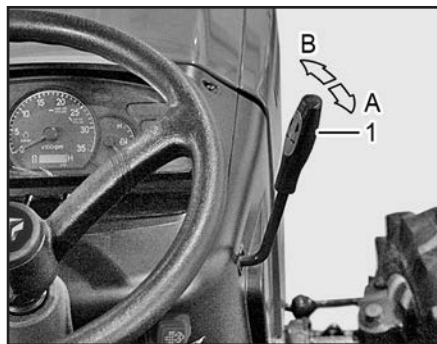
## HAND THROTTLE LEVER



(1) Hand Throttle Lever  
(A)  Low Speed (B)  High Speed

The hand throttle lever is to increase or decrease the engine rpm. This lever is mainly used while working on a field with the constant engine rpm.

 Increasing engine RPM

 Decreasing engine RPM

### NOTE

- Use the foot throttle pedal during driving for travel, not the hand throttle lever.

## PTO ON/OFF SWITCH



(1) PTO ON/OFF Switch

[IND]: In the IND position, the PTO shaft rotates constantly regardless of the position of the rear implement.

[AUTO]: In the AUTO position, the PTO shaft stops rotation when the rear implement is lifted to a certain level. The PTO shaft rotates again as soon as the rear implement is lowered.

## OUTSIDE PTO ON/OFF SWITCH

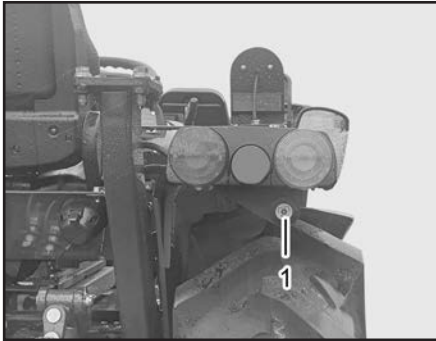

(1) Outside PTO ON/OFF Switch

PTO is activated under the conditions as below.

1. No one in the seat.
2. Hazard lamp and parking brake are in operation.
- 3) Shuttle in neutral.
- 4) Press the PTO switch for 4 sec.

Pressing the switch again to deactivates the PTO.

## DIFFERENTIAL LOCK PEDAL

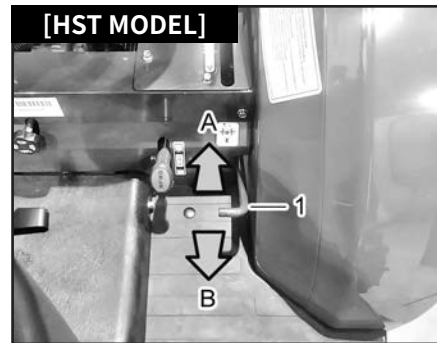
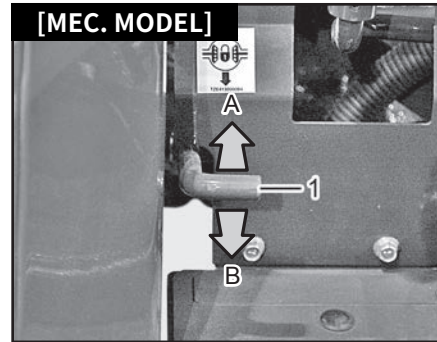

(1) Differential Lock Pedal

(A) Release

(B) Engage

The differential lock pedal is to keep the wheel rotation on both sides the same when one of the rear wheels is idling or spinning without traction. Be sure to use the steering wheel only while the wheels are set in a straight ahead position. Otherwise, the differential system may be damaged.



### WARNING

- Be sure to release the differential lock before making a turn.

## PARKING BRAKE

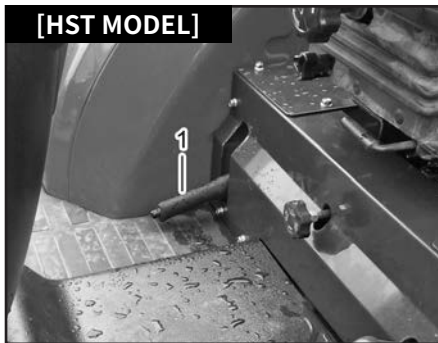
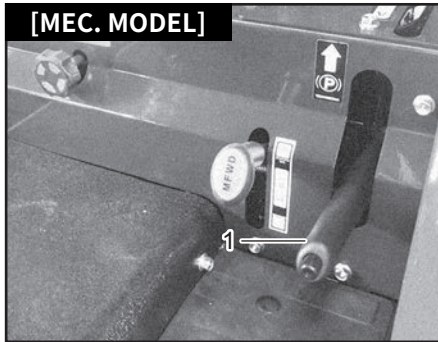

To apply the brake, depress the brake pedals firmly and push the lever forward. To release the brake, depress the brake pedals firmly.

(1) Parking Brake Lever



# 5. OPERATION

## DAILY INSPECTION BEFORE STARTING ..... 5-2

## PRE-OPERATION CHECK..... 5-2

PRE-OPERATION ..... 5-2

BEFORE STARTING THE ENGINE ..... 5-2

RUNNING-IN PERIOD ..... 5-3

## STARTING ENGINE ..... 5-3

HOW TO START ..... 5-3

COLD START ..... 5-6

## STOPPING ENGINE..... 5-6

## TRACTOR OPERATION ..... 5-6

WHEN ATTACHING WEIGHT ..... 5-6

REDUCE SPEED WHEN TOWING LOAD ..... 5-7

HOW TO DRIVE ..... 5-7

STOPPING ..... 5-11

PARKING ..... 5-12

DIFFERENTIAL LOCK ..... 5-13

HOW TO FOLD ROPS ..... 5-14

CONTROL LEVER ..... 5-15

DPF REGENERATION ..... 5-15

## ATTACHMENT OF IMPLEMENT ..... 5-18

ATTACHMENT POSITION ..... 5-18

CENTER LINK ADJUSTMENT ..... 5-19

ATTACHING IMPLEMENT ..... 5-19

ADJUSTMENT OF CHECK BAR ..... 5-21

ADJUSTMENT OF VERTICAL HEIGHT ..... 5-21

POSITIONING OF DRAW BAR ..... 5-22

INSTALLATION OF PTO DRIVEN IMPLEMENT ..... 5-22

HOW TO CONNECT HYDRAULIC HOSE FOR  
LOADER ATTACHMENT ..... 5-23

## CONTROL AND OPERATION OF HYDRAULIC SYSTEM

..... 5-24

SCV CONTROL LEVER AND COUPLER ..... 5-24

CONNECTING CYLINDER HOSE ..... 5-24

TIRES, WHEELS AND BALLAST ..... 5-25

TIRE TYPE ..... 5-25

WHEEL AND AXLE ..... 5-26

## DAILY INSPECTION BEFORE STARTING

### 1. Check the engine oil level.

After wiping out the dipstick, insert it fully and then withdraw it. Oil should be between the two marks on dipstick.

Do not operate the engine if oil level is below minimum mark. If below, add the corresponding grade oil according to the season through the filler.

### 2. Feed grease to all greasing points indicated below every 10 hours when working in damp and muddy conditions.

- Front axle pin
- Steering shaft and Cylinder end
- Tie rod both ends
- Front axle supporter

### 3. After cleaning the machine with highly pressurized water, lubricate the indicated points with grease below if necessary.

- Bonnet latch
- Seat sliding rail

## PRE-OPERATION CHECK PRE-OPERATION

Check the engine operation carefully.

### ⊕ IMPORTANT

- **The engine is tuned or set for normal use. In case of a new tractor, especially carry out inspection and check within first 100 hours.**
- Be sure to warm up the engine. Inspect the battery charge warning lamp, oil pressure warning lamp and engine coolant temperature gauge.
- Avoid any unnecessary engine idling.
- Frequently check the engine oil, coolant, transmission fluid and front axle oil levels. Also, inspect for leakage of those fluids.

### NOTE

- **Make sure to add the corresponding grade oil for the season. Use only genuine oil specified by TYM.**

## BEFORE STARTING THE ENGINE

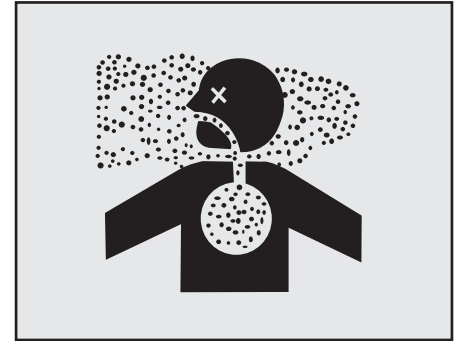

### ⚠ CAUTION

- **Avoid running the engine in an enclosed area. Exhaust gas can be very harmful to your health. If it is unavoidable to run the engine in an enclosed area, extend the exhaust pipe to the outside to release exhaust gas to the atmosphere.**

## RUNNING-IN PERIOD

### ⊕ IMPORTANT

- Always keep wheel bolts tightened to prevent any accident. Confirm that the wheel bolts are tight before operation. Check wheel bolt torque at least twice within the first 10 hours of operation, check it periodically at every 50 hours thereafter. Change the oil and filter after first 50 hours of operation.

#### ▶ Within first 10 hours of operation

- Inspect daily or every 10 hours
- Tighten the wheel bolts

#### ▶ After first 50 hours of operation

- Tighten the wheel, disc and hub bolts
- Check the alternator and fan belt tension as well as air inlet
- Tighten the cooling system's hose and clamp
- Perform the scheduled 50-hour maintenance
- Change the transmission/hydraulic oil and oil filter element
- Change the engine oil and filter
- Change the front axle fluid

## STARTING ENGINE HOW TO START



1. Check the fuel gauge. Make sure that a sufficient amount of fuel is in the tank.

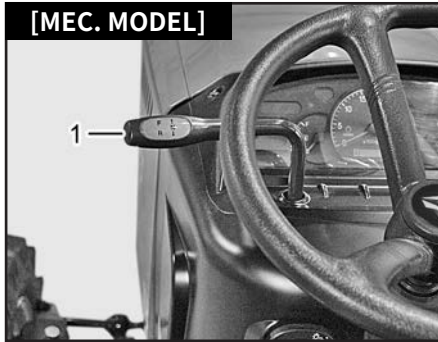

(1) Shuttle shift lever

2. Set the shuttle shift lever in the neutral position. If not, the engine won't be started.



(1) PTO ON/OFF switch

3. Confirm that the PTO switch is set in the OFF position. If not, the engine won't be started. Turn off the PTO switch to the OFF position.



(1) Hitch control lever

(A) Lowering

(B) Lifting

4. Check the position of the implement. Push the control lever forward to lower the implement down onto the ground.

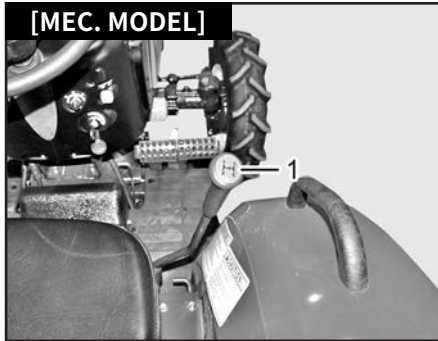

(1) Main shift lever

5. Put the main shift lever in the neutral position.



(1) Hand throttle lever

 Max.  Min.

6. Place the hand throttle lever to the Minimum position.

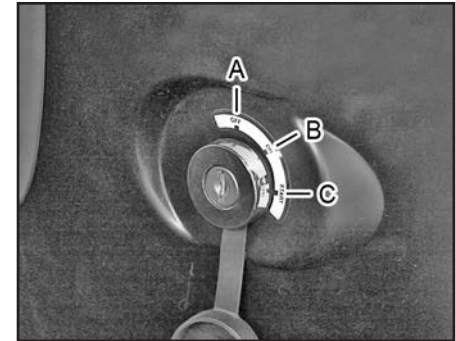

(1) Main switch

(A) OFF

(B) ON

(C) START

7. Turn the main switch to the "START" position. When the engine is started, take your hand off the key.

### IMPORTANT

- Do not operate the start motor more than 20 seconds at a time. If the start motor won't start, wait until the motor is cooled down at least for 2 minutes and then try again.

## COLD START

### CAUTION

- In case of the tractor equipped with the cold start system, do not use starting fluid.

1. When starting in cold weather, turn the ignition switch to the "ON" position and then wait until the preheat indicator is turned off.
2. For safe operation, turn the ignition switch to the "START" position with the clutch pedal depressed.
3. Repeat the above procedures until the engine is operated smoothly.
4. Let the engine idle at 1,200 rpm to warm up the engine up to the operating temperature.

## STOPPING ENGINE

Make sure to reduce the engine rpm with the hand throttle lever in the Low speed position before stopping the engine. Depress the clutch pedal and put all shift levers in the neutral position.

And then turn the main switch to the "OFF" position to stop the engine.

## TRACTOR OPERATION WHEN ATTACHING WEIGHT



### CAUTION

- Do not drive on a road under a heavily loaded condition. Otherwise, it can lead to an injury or machine damage.

1. Reduce the speed when driving on a bumpy or rough ground.
2. Attach the additional weight needed for stability and safe cornering if required.
3. Make sure that the front wheels are not risen up when transporting implements or towing a heavy load.

## REDUCE SPEED WHEN TOWING LOAD

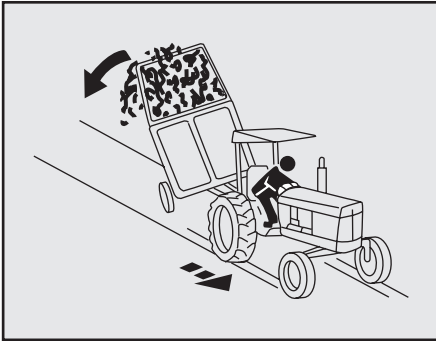

### CAUTION

The stopping distance becomes longer on a downhill in proportion to the speed and load weight. If the towed weight is heavier than the tractor and the braking system is not installed on the trailer, reduce the speed. Observe the guideline for towing speed and capacity.

Observe the guideline for towing speed and capacity as below.

1. If the trailed weight is the same or lighter than the tractor, maintain the maximum speed of 26 km/h.
2. If the trailed weight is twice the tractor or less, maintain the maximum speed of 13 km/h.
3. If the trailed weight is more than twice the tractor, do not tow it.
4. Be careful especially when towing a load on a bad condition of ground, slope or corner.

## HOW TO DRIVE

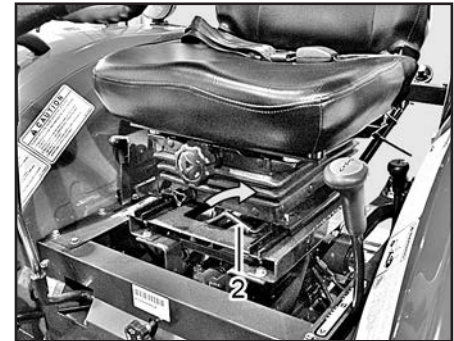

(1) Safety belt

(2) Seat sliding lever

- Adjust the seat properly and fasten the seat belt. Adjust the seat to easily reach the pedal and the steering wheel.

If the seat belt is worn across the abdomen or waist, not the hips, an injury can occur in case of an accident or impact.

Adjust the levers properly according to the driver's physical condition.

### CAUTION

If the tractor is out of control, it can cause a personal injury or even death. Keep the following instructions on a road:

- Interlock the both brake pedals.
- Use the foot throttle pedal.
- Reduce the speed while driving on a slippery, or gravel road.
- Attach the proper weight.
- When reducing the speed, use the brake gently and carefully.

### IMPORTANT

- Don't put a foot on the brake pedal unnecessarily during driving. Such action can reduce the brake's service life.

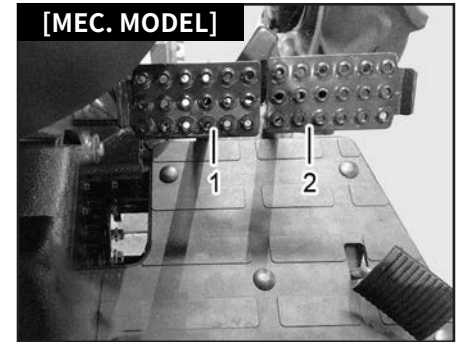

(1) Brake pedal (LH) (2) Brake pedal (RH)

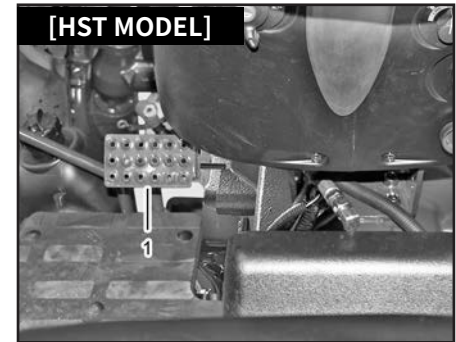

(1) Brake pedal



2. Check if both brake pedals are interlocked.

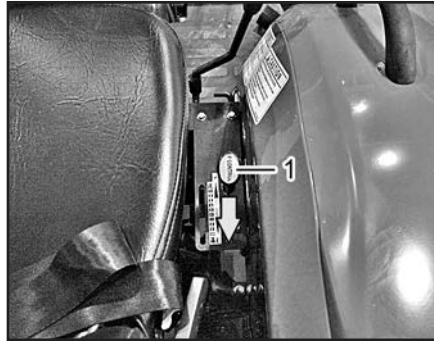

*(1) Control lever*

3. Lift the implement. To lift the installed implement, pull the control lever backward.

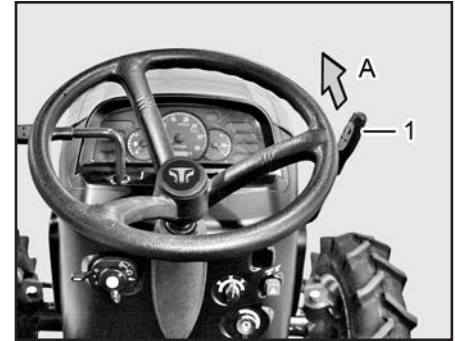

*(1) Hand throttle lever  
(A) Engine rpm increases*

4. Control the hand throttle lever. Increase the engine rpm from low to high speed gradually.

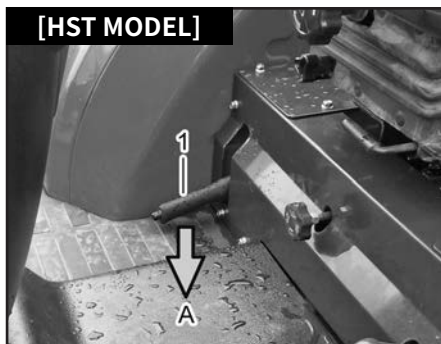
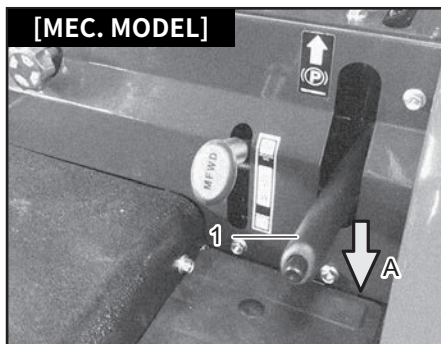

(1) Parking brake lever  
(A) Release

5. Release the parking brake. It can be released by depressing the brake pedal firmly.

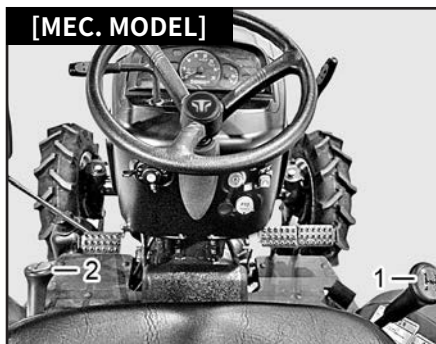

(1) Main shift lever (2) Range shift lever

6. Put the main and range shift levers into the proper positions as the operator's intention.

**CAUTION**

- The range shift lever should be operated while the vehicle is stationary. If not, there is a risk of machinery damage.

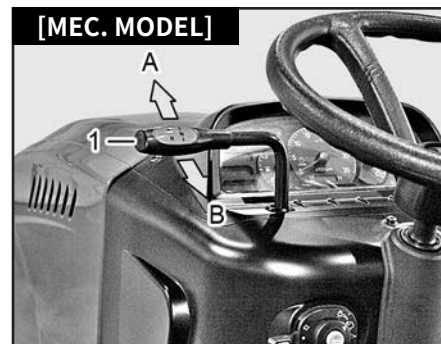

(1) Shuttle shift lever  
(A) Forward (B) Reverse

7. Operate the shuttle shift lever. This lever is used to select forward or reverse driving of the tractor. Shift the lever with the clutch pedal and brake pedal depressed to maximum.

 **CAUTION**

- Don't put a foot on the clutch pedal unnecessarily during driving. Otherwise, the clutch is set in the slip position, resulting in premature wear of the clutch.
- Do not change the tractor speed abruptly for safe driving.
- Be careful of all directions of the tractor before driving. If not, it can cause an accident.
- When driving on a steep slope or moving to a location for loading or unloading, do not put your hand on the main shift lever. If the shift lever is half engaged, it can lead to an accident. Make sure to place the lever in the low speed position in advance.

**STOPPING**

1. Stop the tractor with the brake pedal and clutch pedal.
2. Put the main shift lever to the neutral position.
3. Put the shuttle shift lever to the neutral position.
4. Put all SCV levers to the neutral position.
5. Set the PTO switch in the OFF position.
6. Lower all implements on the ground.
7. Push the hand throttle lever back slowly to decelerate the engine and keep the engine for 1 - 2 minutes of unloaded idling.
8. Make sure the parking brake is applied.
9. Turn the main switch to the OFF position to stop the engine.

 **CAUTION**

- When leaving the tractor, put the shuttle shift lever into the neutral position. If not, the tractor may move even though the engine is stopped.

## PARKING

### ⊕ IMPORTANT

- The tractor needs to be stationary before making a shift. If the parking brake is applied while the tractor is moving, the transmission can be damaged.
- Each part of the engine is cooled down by the engine oil. If the hot engine is suddenly stopped, its high temperature or insufficient lubricant can cause damage to the related parts.

### ⚠ CAUTION

- Remove the ignition key before leaving the tractor to prevent its use by an unqualified person.

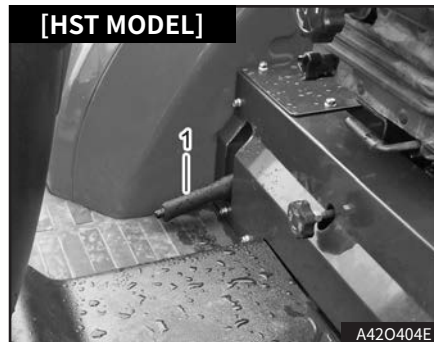
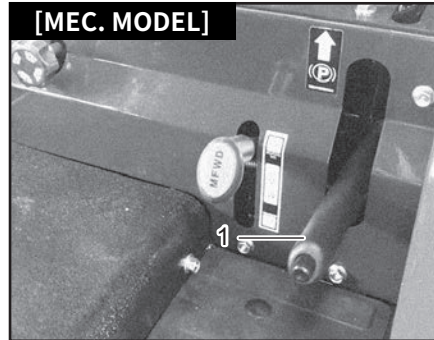

(1) Parking brake lever

When parking the tractor, securely engage the parking brake by pulling the parking brake lever completely. To release the parking brake, depress the parking brake pedal firmly.

### ⚠ CAUTION

- The brake disc can be rapidly worn if you drive with the parking brake applied. To park the vehicle, apply the parking brake and then place prop under the rear wheels.

## DIFFERENTIAL LOCK

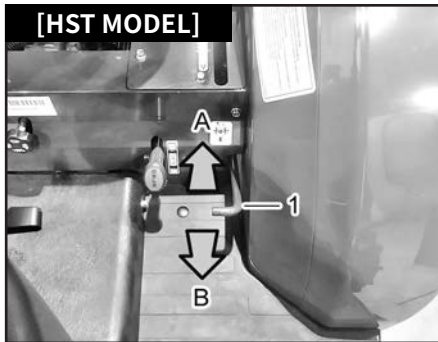
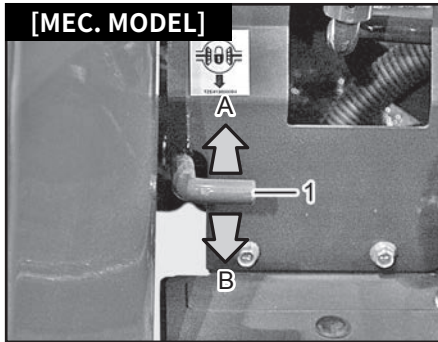

(1) Differential Lock Pedal  
 (A) Release (B) Engage

**CAUTION**

- Do not drive the tractor at high speed or make a turn with the differential lock engaged.

**IMPORTANT**

- To prevent the power train from damage, do not press the differential lock pedal when one wheel is spinning fast and the other wheel is stopped.

1. When the speed at one wheel starts to drop, depress the differential lock pedal to activate the differential lock.
2. If the wheel traction resistance on both wheel is not even, the differential lock keeps being engaged. While both wheel traction resistance is even, the differential lock is automatically disengaged. If the differential lock is not disengaged, depress one and another brake pedal separately.

3. If the tire is rotating idle repeatedly, try to engage the differential lock again.

## HOW TO FOLD ROPS

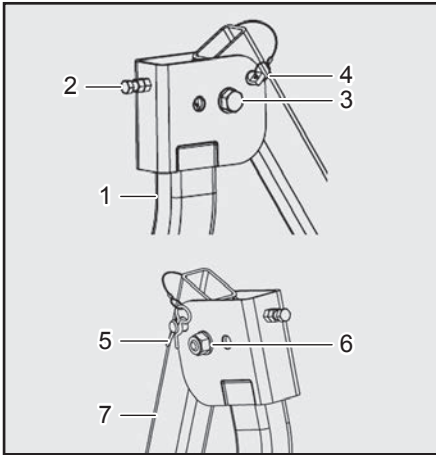

1. Loosen the bolt (3) and nut (6) of the frame. (Do not unscrew them completely.)
2. Unfold the upper frame backward after removing the snap pins (4) and pins (5) on both sides.



### CAUTION

- Be careful as the frame can fold by its weight, resulting in injuries, including head, shoulder and hand injuries.

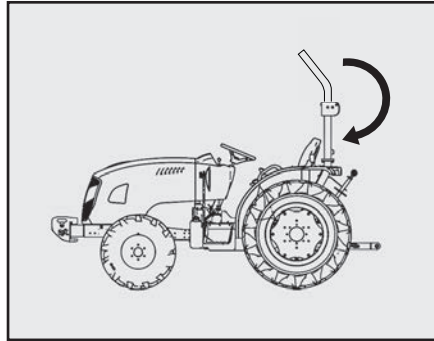

3. Fit the pins (5) through the holes of the frames (1 & 7) and fit the snap pins (4) into the holes of the pins (5) to fix the frames.
4. Tighten the bolt (3) and nut (6) firmly.



### WARNING

- Do not modify or disassemble the safety frame without approval.

- If the safety frame is incorrectly installed, it can lead to a severe accident during a rollover accident.
- Make sure to install the bolts, pins and nuts properly to set the safety frame upright securely.
- To fold the safety frame
  - The safety frame is heavy. Have others help you with folding or unfolding the frame.
  - The safety frame may fold abruptly by its weight. Make sure no injury is occurred by dropping frame.
  - While the safety frame is folded, do not wear the seat belt.
  - When the safety frame is unfolded back and work is done, set the frame upright immediately before starting to drive.

## CONTROL LEVER



(1) Control lever

(A) Lowering

(B) Lifting

1. This control lever can be used to lower and lift an implement freely.
2. Pulling the lever back lifts the implement while pushing it forward lowers the implement.

### CAUTION

- To avoid a personal injury, use the control lever when attaching/detaching the implement.

## DPF REGENERATION



(1) DPF Regeneration Switch

### 1. Engine Max Rpm

Keep above 3,000 rpm with Accel Lever. However, the following conditions must be satisfied.

- Parking on
- Gear Neutral
- Shuttle Neutral (Mechanical) & Pedal Neutral (HST)
- Cooling water temp. 60°C~100°C

2. To press the regeneration button for more than 3 seconds.

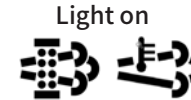

Press and hold for more than 3 seconds to display the related regeneration lamp on the instrument Panel.



3. DPF regeneration completed after 30 minutes.





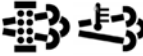

When the DPF regeneration is completed, the regeneration lamp is turned off on the instrument panel.

**DPF REGENERATION INDICATION**

Items	Lamp Indication		Description
DPF regeneration time reached		Light on	If the DPF has more than a certain amount of soot, it informs the driver that it is time to regenerate. [Buzzer] Buzzer sounds 3 times every minute.
DPF regeneration starts			If driver press the regeneration button for more than 3 seconds in high idle (2,850 rpm or more), driver can enter the regeneration mode. [Buzzer] Buzzer sounds for 2 seconds at start
DPF regeneration proceeding		Light on	Controlling the exhaust valve to burn soot on the DPF. [Buzzer] Buzzer sounds once every 3 minutes
		Blinking per 0.5 sec	
DPF regeneration complete		Lamp Off	Regeneration is completed after 30 minutes from the start of regeneration. [Buzzer] Buzzer sounds 3 times after 3 minutes of DPF regeneration.



## ERROR DISPLAY DURING DPF REGENERATION

Items	Lamp Indication		Description
Engine overheating		Blinking	Activates when the cooling water temperature exceeds 105 degrees during DPF regeneration. You can not retry regeneration within 10 minutes. [Buzzer] Repeat 1Sec Sound On→0.5 Sec Sound Off, and if it goes below 100 degrees, Buzzer is turned off.
Regeneration fail		Blinking	By judging after the end of the regeneration period, it activates when the differential pressure does not decrease by more than 100mbar compared with the start of regeneration even though the differential pressure is blocked at the start of regeneration.
3 times consecutive regeneration failures		Blinking	Even if the DPF regeneration has been completed after 3 consecutive regeneration tries, check the pressure difference due to soot.
Regeneration off		Blinking	If regeneration stop during regeneration operation for any of the following reasons. -Engine less than 2,600 rpm -Post DPF(EGTS2) temperature overheat -Not parking
Engine stop during regeneration		Blinking for 10 min	Blinking for 10 minutes if engine stop is detected during regeneration and the differential pressure is greater than 130 mbar at restart.
DPF error		Light on	Activates when the DPF is damaged or removed.

## ATTACHMENT OF IMPLEMENT ATTACHMENT POSITION

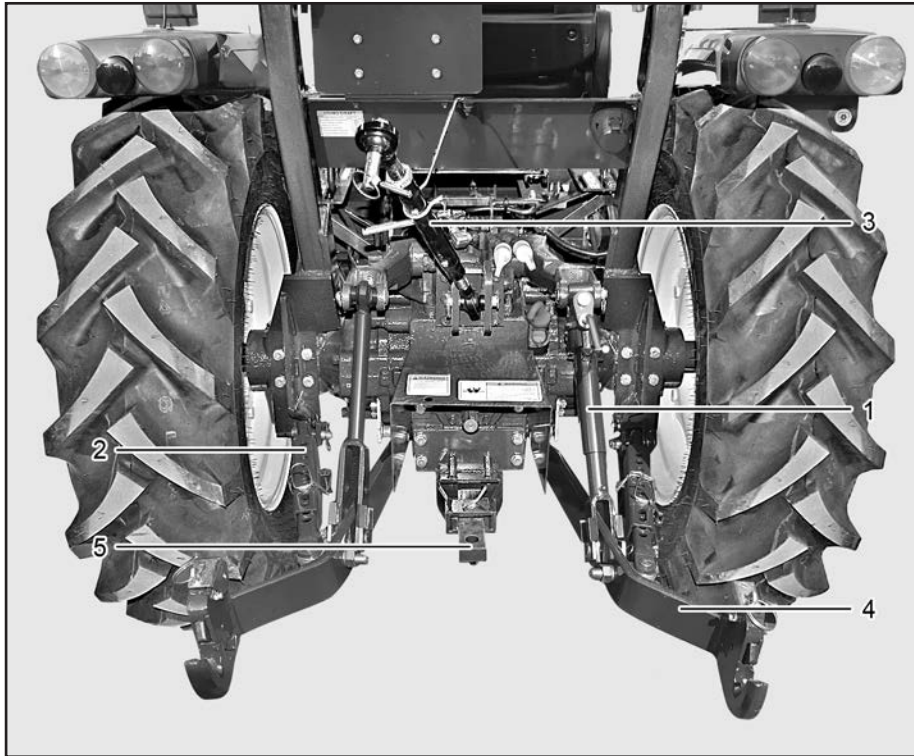

(1) Lift link  
(2) Check bar

(3) Center link  
(4) Lower link

(5) Draw bar

### CAUTION

Select an implement to match the tractor horse power;

The tractor horse power should correspond with the size of an implement. If the power level of tractor is exceeded, the implement may be damaged. Also, if the implement is too big, the tractor may be damaged. Be sure of the maximum and minimum power of the tractor before attaching an implement.

## CENTER LINK ADJUSTMENT

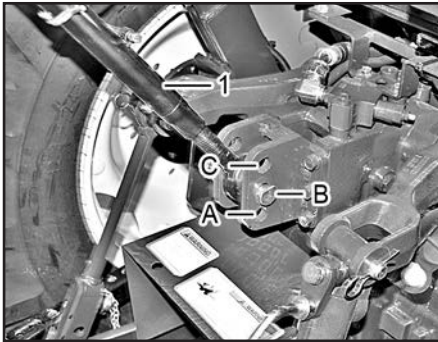

(1) Center link      (A) High traction  
(B) Mid traction    (C) Low traction

The center link can be installed to 3 selective positions according to the working condition.

A: If the center link is attached to the bottom position, the draft system will be activated with highest sensitivity which is suitable for the implement such as a plow or equivalent which requires traction force.

B: The center hole is the standard installation hole for a rotary tiller.

C: If the center link is attached to the top position, the draft system will not be activated. Therefore, it is good for the implement such as a drilling machine or equivalent which does not require any traction force.

## ATTACHING IMPLEMENT

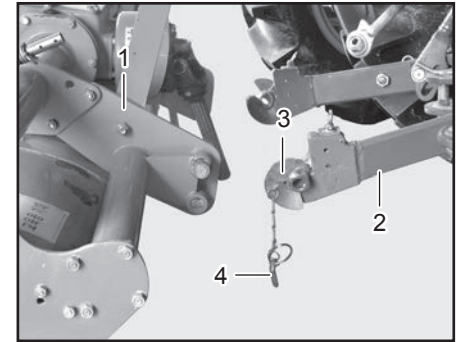

(1) Implement      (2) Lower link  
(3) Ball            (4) Lock pin

1. Drive the tractor backward to move close to an implement to fit the position of 3-point hitch.
2. Apply the parking brake and stop the engine.
3. After inserting the hitch pins of the implement into the lower links, secure it with the lock pin.

**⚠ WARNING**

- To prevent the rocker shaft from unexpected movement, turn "OFF" the traction (draft) control before attaching the implement to the hitch.

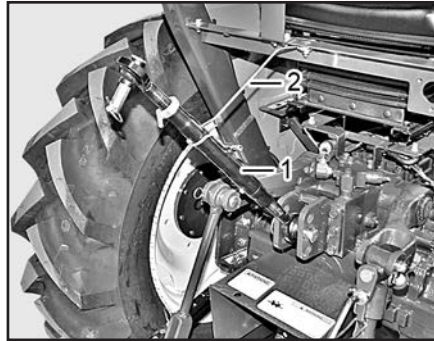

(1) Center link      (2) Fixing bracket

**⚠ CAUTION**

- Always check if there's no interference with the implement, quick-coupler of the implement, and other attachments when attaching to the 3-point hitch to avoid fatal personal injury or machinery damage.

4. Detach the center link from the fixing bracket.
5. Attach the center link to the top mast of the implement.
6. Adjust the length of the center link and lower link if required.

## ADJUSTMENT OF CHECK BAR

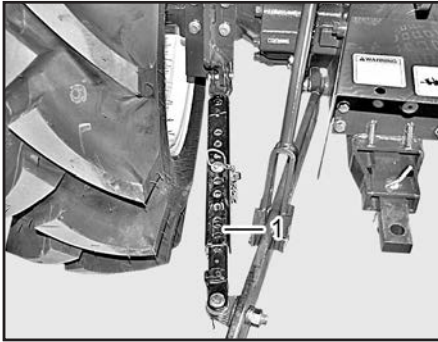

(1) Stabilizer

1. For implements such as a plow and disc harrow, adjust the length so that it can be moved for 5 - 6 cm sideways.
2. For implements such as a rotary tiller and mower, adjust the length so that it cannot be swayed sideways.

## ADJUSTMENT OF VERTICAL HEIGHT

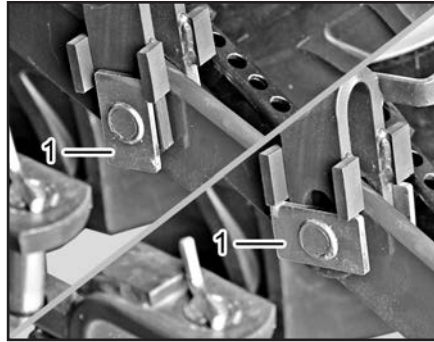

(1) Rectangular steel plate

1. To let the implement float along contour of the ground, turn the rectangular steel plate to the vertical position.
2. To secure the implement, turn the rectangular steel plate to the horizontal position.

### ⊕ IMPORTANT

- Do not extend the center link excessively out of the limit. The center link's body or thread can be damaged.

## POSITIONING OF DRAW BAR

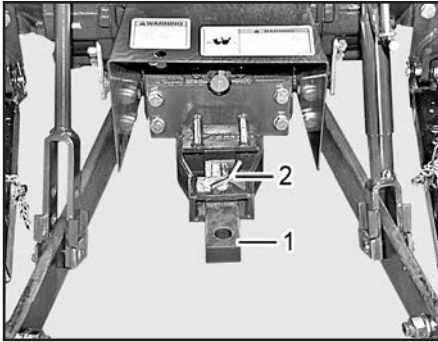

(1) Draw bar

(2) Lock pin

Make sure to use the drawbar when towing the implement such as a trailer. In case of using the 3-point hitch (PTO drive), retract the draw bar to its shortest position and secure it.

The draw bar is adjusted in 2 stages.

1. Hold the draw bar and pull out the lock pin from the bracket.
2. Move the draw bar front and back to fit the lock pin.
3. When towing a heavy load, tow it with shortest draw bar position.

## INSTALLATION OF PTO DRIVEN IMPLEMENT

1. Attach the implement to the tractor.
2. Lift the implement off the ground.
3. Stop the engine and put the PTO shift lever in the neutral position.
4. After opening the PTO cover, connect the universal joint shaft while turning the PTO shaft by hand so as to align the splines.
5. To check the PTO shaft is secured, check if the pin is returned to the original position by pulling the universal joint shaft.
6. Close the PTO cover.
7. Adjust the PTO shift lever according to the working speed.
8. Check if the safety shields are in place and working environment is normal. If the master safety shield is not installed, do not operate the PTO. Stop the engine to check the PTO shaft and its guards Repair or lubricate if required.
9. The PTO shaft should not be interfered by any surrounding parts.

## HOW TO CONNECT HYDRAULIC HOSE FOR LOADER ATTACHMENT

### ⚠ CAUTION

- If someone is entangled in the rotating part, it can cause a fatal injury. Always wear protective gear and install the safety shields and guards to the drive line. Don't wear loose clothing.
- Do not remove the installed protective cover of the PTO drive shaft without permission. If working with this protective cover removed, it can cause a severe injury. Refer to the warning decal on the cover.

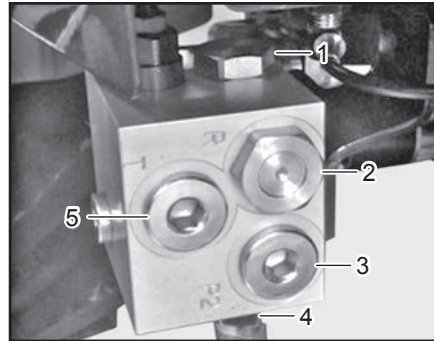

- (1) R2                      (2) R1  
 (3) P2                      (4) P1  
 (5) T

### ⚠ CAUTION

- Before installing a loader, make sure to stop the engine in advance and connect its hydraulic hose.

## HYDRAULIC CIRCUIT OF FRONT OUTLET VALVE

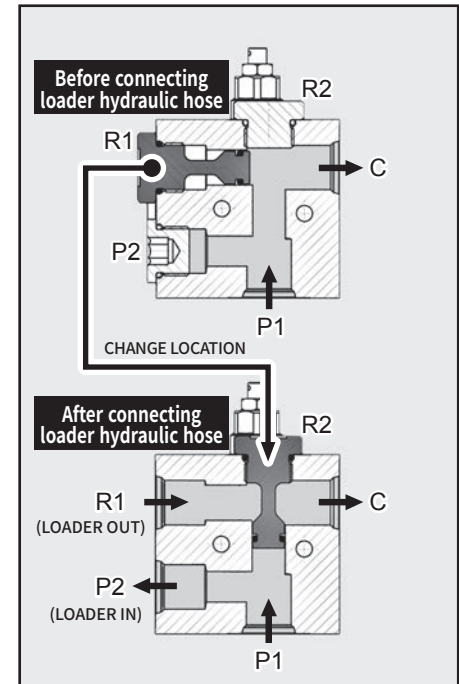

When installing a loader, the plug of the port R1 should be fit to the port

R2 to enable correct operation of the loader.

### CAUTION

The hydraulic hoses are subject to physical wear, aging and explosion. Make sure to inspect the hoses on a regular basis. If any hose is damaged, replace it with a new one immediately.

## CONTROL AND OPERATION OF HYDRAULIC SYSTEM SCV CONTROL LEVER AND COUPLER

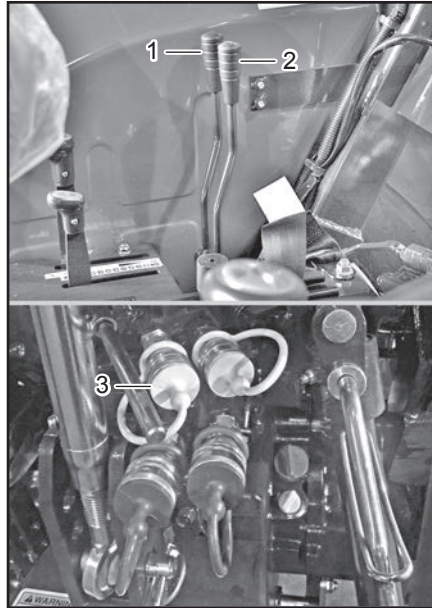

- (1) SCV control lever 1  
 (2) SCV control lever 2  
 (3) Coupler

The levers (1 and 2) adjust the oil flow rate and direction of the SVC valves located on the rear side of the tractor. The left coupler is for expansion and the right coupler is for retraction.

1. Distinguish the hoses for expansion and retraction. The hose for expansion should be connected to the left coupler while the hose for retraction should be connected to the right coupler.
2. Remove the dust cap from the hose end.
3. Push the coupler cap.
4. Check if the hose end and the coupler are clean. Insert the hose tip into the coupler correctly. Pull the hose one time to check that it is properly inserted.
5. When connecting the outer hydraulic hose, be careful not to allow foreign material to enter it. Necessarily keep the connector clean during installation.



### ⚠ CAUTION

- Escaping hydraulic fluid under pressure has sufficient force to penetrate skin, causing a serious personal injury. Be sure to release all residual pressure before disconnecting hydraulic lines. Before adding pressure to the hydraulic system, make sure to tighten all connections.
- To check leakage, use a cardboard and protect your hands and feet from the pressurized fluid.
- If injured by escaping fluid, see a medical doctor at once. This fluid injected in the skin can produce gangrene and/or severe allergic reaction.
- The outer hydraulic pipes are subject to physical wear, aging and explosion. Failure to perform periodic inspections may lead to a fluid leak. Periodically inspect the hoses and immediately replace if required.

## TIRES, WHEELS AND BALLAST TIRE TYPE

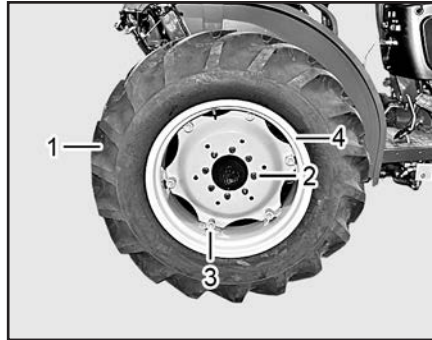

- (1) Tire                      (2) Wheel nut  
(3) Rim bolt                (4) Rim

Though the tire pressure is factory set to the prescribed level, it naturally drops slowly in the course of time. Thus, check it everyday and inflate as necessary.

## PROPER INFLATION PRESSURE

		Tire size	Inflation pressure (kg/cm <sup>2</sup> )
With rotary tiller	Front wheel	8-16	2.0
	Rear wheel	12.4-24	1.3
With loader	Front wheel	8-16	3.0
	Rear wheel	12.4-24	2.0

## TIGHTENING TORQUE

	Specification
Wheel & axle mounting bolt	167 - 206 N.m (17 - 21 kgf.m)
Wheel rim and disc mounting bolt	167 - 206 N.m (17 - 21 kgf.m)

**FRONT WHEEL ASSEMBLY**

Front wheel	A	B	Remarks
F25R(H) F36R(H) F42R(H) F50R(H)	1,234	1,519	8-16 4PR
F25Rn(hn) F36Rn(hn) F42Rn(hn) F50Rn(hn)	1,108	1,397	

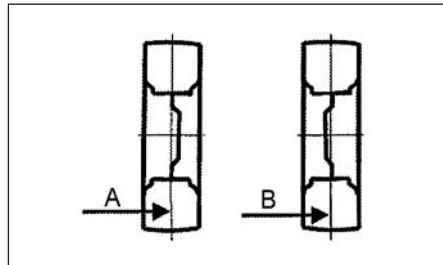

**REAR WHEEL ASSEMBLY**

Front wheel	C	D	E	F
F25R(H) F36R(H) F42R(H) F50R(H)	1,024	1,130	1,174	1,280
F25Rn(hn) F36Rn(hn) F42Rn(hn) F50Rn(hn)	1,024	1,130	1,174	1,280

\* Tire size : 12.4-24 6PR

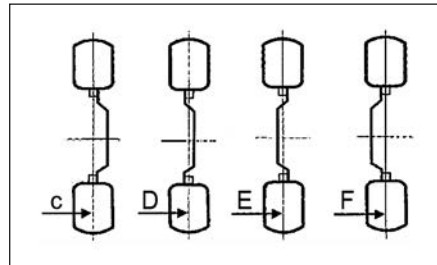

**WHEEL AND AXLE**

If the wheel or axle is loosened, tighten to the specified torque.

1. Drive the tractor about 100 m and tighten it to the specified torque.
2. Inspect the wheel and axle every 10 hours of engine run or every 3 hours of working.
3. Inspect all wheels and axles frequently and securely tighten if necessary.

 <b>CAUTION</b>
<ul style="list-style-type: none"> <li>• Never operate the tractor with a loose rim, wheel, hub or axle.</li> </ul>

<b>NOTE</b>
<ul style="list-style-type: none"> <li>• When operating a new tractor or when removing the wheel, follow the procedures above.</li> </ul>

## 6. MAINTENANCE

**MAINTENANCE SCHEDULE CHART ..... 6-2**

**FLUIDS..... 6-4**

FLUIDS AND CAPACITY..... 6-4

**ROUTINE MAINTENANCE..... 6-5**

OPENING HOOD..... 6-5

CHECKING AND REPLACING ENGINE OIL..... 6-5

CHECKING AND CHANGING TRANSMISSION FLUID 6-6

CHECKING AND CHANGING FRONT AXLE OIL..... 6-7

REPLACING ENGINE OIL FILTER ..... 6-7

REPLACING TRANSMISSION FLUID FILTER ..... 6-8

CHECKING AND CHANGING COOLANT..... 6-9

ANTI-FREEZE..... 6-9

CHECKING AND ADDING FUEL ..... 6-10

CHECKING BATTERY ..... 6-10

CHECKING HOSES AND PIPES..... 6-11

CHECKING ELECTRIC WIRING..... 6-11

GREASING ..... 6-12

CHECKING AND ADJUSTING STEERING WHEEL..... 6-12

CHECKING AND ADJUSTING BRAKE..... 6-12

CHECKING FUEL FILTER WATER SEPARATOR ..... 6-13

CHECKING EXHAUST GAS..... 6-14

CHECKING FUSE AND FUSIBLE LINK..... 6-14

CHECKING AND ADJUSTING TOE-IN ..... 6-15

CHECKING AND ADJUSTING FAN BELT..... 6-15

## MAINTENANCE SCHEDULE CHART

○ : Check · Add · Adjust      ● : Replace  
 ★ : Replace at first time only    △ : Clean

INSPECTION PART	HOUR														YEAR	
	50	100	150	200	250	300	350	400	450	500	550	600	650	700	1YR	2YR
ENGINE OIL LEVEL	CHECK BEFORE EVERY WORK															
ENGINE OIL & FILTER	★					●					●				●	
FUEL FILTER										●						
FUEL HOSE & BAND	CHECK BEFORE EVERY WORK															●
AIR CLEANER ELEMENT		△		△		△		△		●		△		△		●
AIR CLEANER HOSE & BAND	CHECK BEFORE EVERY WORK															●
INLET HOSE & BAND	CHECK BEFORE EVERY WORK															●
COOLANT																●
COOLANT LEVEL	CHECK AND ADD BEFORE EVERY WORK															
RADIATOR & RADIATOR NET	CHECK AND CLEANING BEFORE EVERY WORK															
RADIATOR HOSE & BAND	CHECK BEFORE EVERY WORK															●
FAN BELT & A/C BELT		○		○		○		○		○		○		○		
BATTERY		○		○		○		○		○		○		○		

- ※ Replace the fan belt & a/c belt as required.
- ※ Charge and replace the battery as required.
- ※ Inspection should be done every 50 hours. If the tractor is not used much, inspect every year.
- ※ Replace a part at running hour or year whichever comes first.

○ : Check · Add · Adjust      ● : Replace  
 ★ : Replace at first time only    △ : Clean

INSPECTION PART	HOUR														YEAR	
	50	100	150	200	250	300	350	400	450	500	550	600	650	700	1YR	2YR
TRANSMISSION OIL	★	○	○	○	○	○	●	○	○	○	○	○	○	○		
TRANSMISSION OIL FILTER	★	○	○	○	○	○	●	○	○	○	○	○	○	○		
FRONT AXLE OIL	★	○	○	○	○	○	●	○	○	○	○	○	○	○		
FUEL PIPE & CONNECTION	CHECK BEFORE EVERY WORK															●
STEERING WHEEL HOSE	CHECK BEFORE EVERY WORK															●
HYDRAULIC OIL HOSE		○		○		○		○		○		○		○		
ELECTRIC CABLES	CHECK BEFORE EVERY WORK															
GREASING	CHECK BEFORE EVERY WORK															
TIGHTENING HANDLES		○		○		○		○		○		○		○		
TIGHTENING BOLTS & NUTS	○	○		○		○		○		○		○		○		
CLUTCH		○		○		○		○		○		○		○		
BRAKE		○		○		○		○		○		○		○		
ENGINE BREED PIPE	○	○		○		○		○		○		○		○		
ENGINE CRANKCASE						△						△				
INTAKE/EXHAUST GAS VALVES												○				
FUEL INJECTION VALVE												○				
GENERATOR MOTER	○	○				○				○				○		
HYDARAULIC SYSEM	○	○				○				○				○		

## FLUIDS FLUIDS AND CAPACITY

No.	Fluid	Capacity (ℓ)	Specification	Remarks
1	Fuel	27	Diesel fuel (KS2)	For summer: S, For winter: W
2	Engine oil	4.3	SAE 15W-40	CJ grade or higher
3	Grease	As needed	KSM2130 NO.2	Multi purpose type
4	Coolant	Radiator: 5.0 ℓ (1.32 u.s. gal) Reservoir tank: 0.45 ℓ (0.12 u.s. gal)	Appropriate genuine antifreeze	NO.2 of KSM2142 or equivalent, permanent type
5	Transmission oil(Also for hydraulic steering wheel)	34 (Mec. Model) 37 (HST Model)	TF500	TEXCO TDHOIL, 1893 CHEVRON tractor hydraulic fluid
6	Front axle	6.4	SAE#90	

 **WARNING**

- Check the oil level regularly. Correct the oil level, if needed, before operating.
- Always check and add oil with the tractor on a flat, level surface.

## ROUTINE MAINTENANCE OPENING HOOD

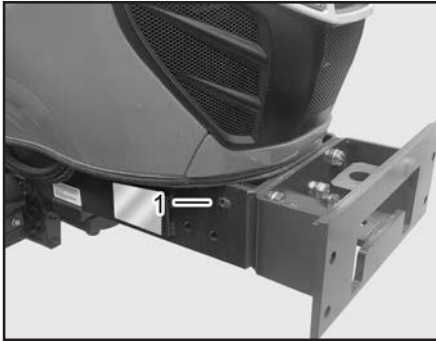

(1) Opening lever

- 1.The hood can be unlocked by pressing the bonnet open lever with a separate tool.
- 2.Slightly lift the hood with both hands and the hood is automatically lifted by the gas spring.
- 3.To close the hood, press its front down slightly until a "click" sound is heard.
- 4.After closing the hood, lift it to check that the hood is securely fixed.

## CHECKING AND REPLACING ENGINE OIL CHECKING

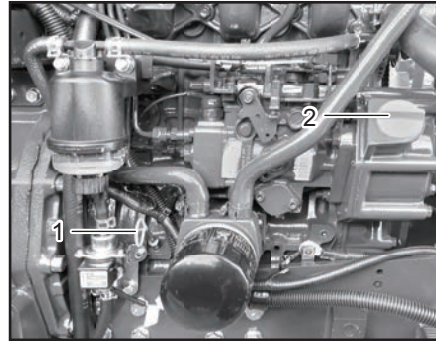

(1) Oil dipstick

(2) Oil inlet

Pull out the oil dipstick, clean it, and then insert it into its original position. Then, pull it out again and check if the oil level is within the specified range. If the oil level is too low, add new oil so that the level is within the allowable range.

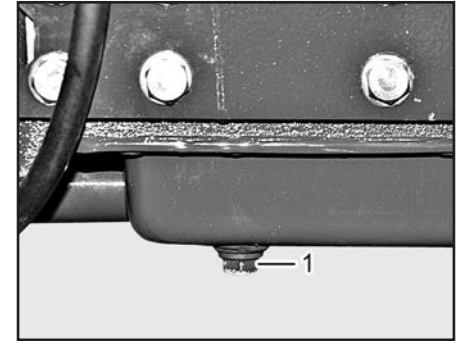

(1) Drain plug

To drain oil, remove the drain plug on the bottom of the engine. Fill new engine oil through the filler after installing the drain plug. Change engine oil periodically with proper engine oil according to the temperature and operating condition.

### NOTE

- First 50HR engine oil has to be changed.

## CHECKING AND CHANGING TRANSMISSION FLUID

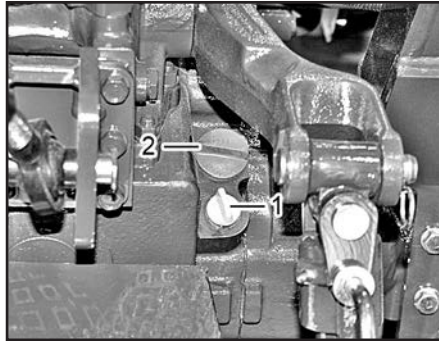

(1) Oil dipstick (2) Oil Inlet

Pull out the oil dipstick from the top of the rear axle housing on the left. Then, wipe it end clean, insert it into the housing, and pull it out again to check if the oil level is between the upper and lower limit marks. If the oil level is too low, add some new oil so that the level is within the allowable range. Also, check for leakage.



(1) Rear axle case  
(2) Transmission case  
(3) Oil Inlet

### CHANGING

Drain transmission fluid by removing the drain plug from the transmission or rear axle case. Change transmission fluid periodically with proper one according to the temperature and operating condition.

#### DANGER

- Be sure to turn "OFF" the ignition switch to stop the engine before pulling out the oil dipstick.

#### CAUTION

- Drain oil while it is warm. However, if it is excessively hot, be careful of a burn.

#### NOTE

- First 50HR transmission fluid has to be changed.



## CHECKING AND CHANGING FRONT AXLE OIL

### CHECKING

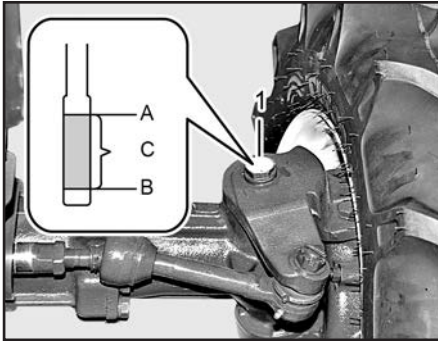

(1) Filler plug  
 (A) Upper limit      (B) Lower limit  
 (C) Specified level

Unscrew the oil filler plugs on the left sides of the front axle housing, wipe them clean, and then insert them into their original position. Then, pull them out again and check if the oil level is within the specified range. If the oil level is too low, add some new oil so that the level is within the allowable range. Also, check for leakage.

### CHANGING

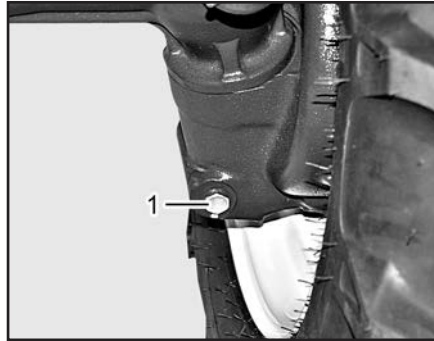

(1) Drain plug

To drain the used oil, remove the right and left drain plugs under the front axle and drain the oil completely.

#### NOTE

- **First 50HR front axle oil has to be changed.**

## REPLACING ENGINE OIL FILTER

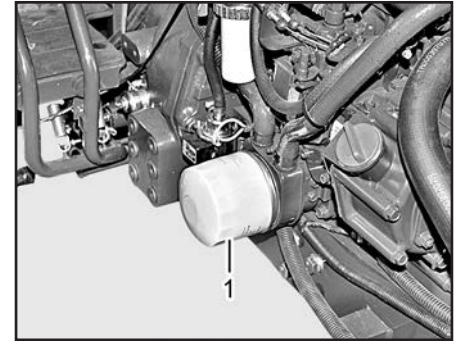

(1) Oil filter cartridge

1. After draining engine oil, remove the oil filter cartridge by turning it counter-clockwise with a filter wrench.
2. Apply a thin film of oil to the rubber ring on the bottom of a new filter and securely install it.
3. After changing engine oil, start and run the engine until the hydraulic pilot lamp is turned off.

4. Check the engine oil level again with the oil dipstick after the hydraulic pilot lamp is turned off. If the level is low, add more oil.
5. This filter is a cartridge type. Replace it at every 300 hours of operation.

<b>NOTE</b>
<ul style="list-style-type: none"> <li>• First 50HR engine oil filter has to be changed.</li> </ul>



## REPLACING TRANSMISSION FLUID FILTER

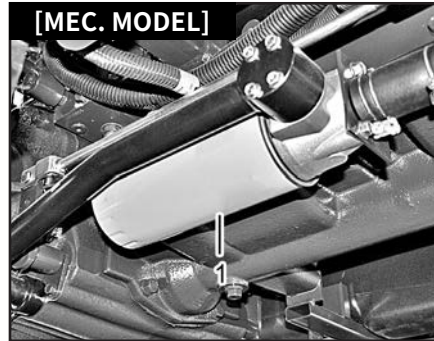

(1) Oil filter cartridge

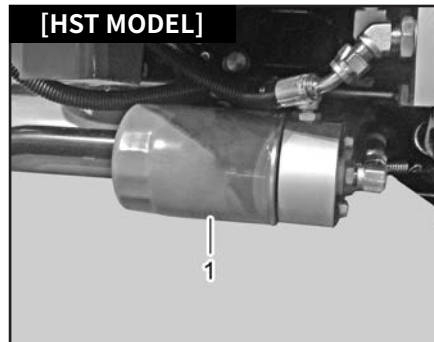

(1) HST filter cartridge

1. After draining transmission oil, remove the oil filter cartridge by turning it counterclockwise.
2. Apply a thin film of oil to the rubber ring on the bottom of a new filter and securely install it.
3. After changing transmission oil, run the engine to deliver oil to each part, and then stop the engine.
4. Check the transmission oil level again with the oil dipstick. If the level is low, add more oil.
5. This filter is a cartridge type. Replace it at every 300 hours of operation.

<b>NOTE</b>
<ul style="list-style-type: none"> <li>• First 50HR transmission fluid filter has to be changed.</li> </ul>

## CHECKING AND CHANGING COOLANT CHECKING

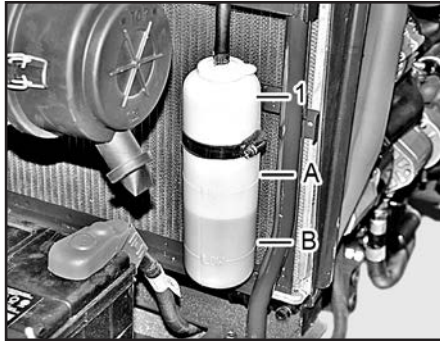

(1) Coolant reservoir tank  
(A) FULL (B) LOW

Open the hood and check if the coolant level in the reservoir tank is between the "FULL" and "LOW" marks. Add coolant through the filler if necessary.

## REPLACEMENT PROCEDURE

1. To drain coolant, open the radiator cap and drain plug and drain coolant completely from the radiator.
2. Flush the radiator until clean water is drained.
3. Add anti-freeze up to the filler neck of the radiator.
4. Start and operate the engine for 5 minutes after filling the reservoir tank with coolant up to the "FULL" level. At this time, press the heater switch of the air conditioner to activate the heater. Stop the engine and check if the coolant level is between the "FULL" and "LOW" marks. If not, add some coolant as needed.

## ANTI-FREEZE

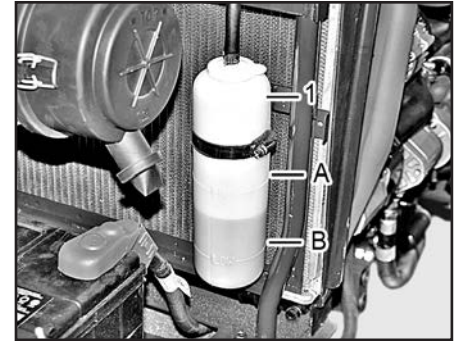

(1) Anti-freeze reservoir tank  
(A) FULL (B) LOW

The anti-freeze is lowering the freezing temperature of water. The tractor is filled with appropriate genuine anti-freeze at factory.

**⚠ CAUTION**

- When changing with new coolant, add anti-rust agent and idle the engine for 5 minutes for mixing.
- As the coolant level is reduced naturally, fill with clean and fresh water.
- The expiration date on anti-freeze is 1 year. Make sure to change it every year.

## CHECKING AND ADDING FUEL

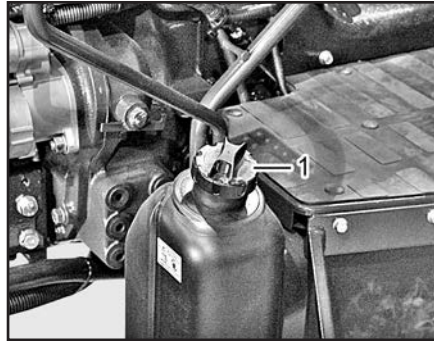

(1) Fuel cap

Turn the main switch to the "ON" position. If the fuel gauge needle is pointing the red area, open the fuel cap, and then fill the fuel tank full through the oil filler. Open the engine side cover and check if there is leakage.

**⚠ DANGER**

- Never smoke or use a lighter while refueling the tractor.
- After refueling, securely close the fuel cap and wipe off any spilled fuel.

## CHECKING BATTERY

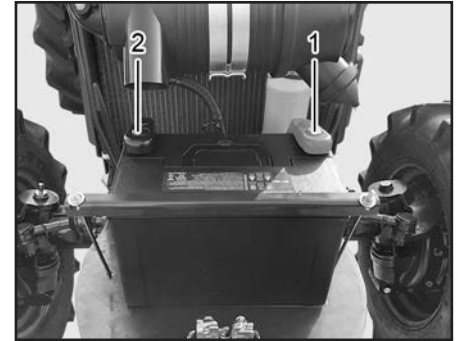

(1) Thick red wire (+) (2) Ground cable (-)

Check if the electrolyte level is within the specified range and add distilled water up to the upper limit if necessary.

**⚠ DANGER**

- Do not expose the battery to flames or sparks.

If this instruction is ignored, you can get burnt by battery explosion.

**CAUTION**

- To connect the battery, connect its positive (+) cable first. To disconnect the battery, disconnect its negative (-) cable first.
- If the amount of electrolyte is excessive in each cell during charging the battery, the metal part of the tractor can be corroded due to the spilled electrolyte.
- Avoid boost charging as possible.
- Charge the battery after removing it from the tractor.
- When replacing the battery, use the TYM genuine battery.

## CHECKING HOSES AND PIPES

Check the fuel hose, hydraulic steering wheel hose (pipe), radiator hose, etc. for damage or leakage. Check if there is any loose bolt. Replace the hoses and pipes every 2 years even if not damaged.

**DANGER**

- Make sure that fuel does not leak through the damaged fuel hose.

## CHECKING ELECTRIC WIRING

Open the hood and check if any cable is in contact with other parts, or if any insulation is peeled off or damaged, or if any contact is loose. Damaged cables must be repaired by an authorized dealer. Arrange for periodic maintenance for cables every 50 hours or once a year even though the cables are not damaged.

**DANGER**

- Before starting to work every day, check if any cable is in contact with other parts, or if any insulation is peeled off or damaged, or any contact is loosened.
- Before and after work, remove any straw or dust on the battery or cables.

## GREASING

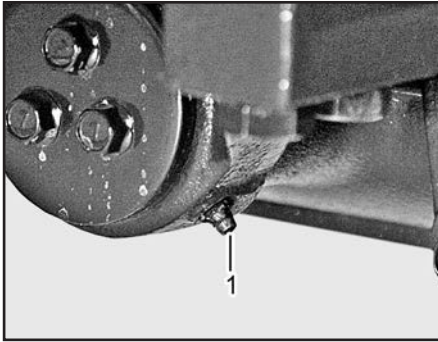

(1) Nipple

Apply grease every 50 hours. Check the relevant parts (9 points) before starting work everyday and add grease as necessary.

### ► Greasing points

- Axle bracket (front & rear)
- Axle tie rod end (LH/RH)
- Brake and clutch pedals
- Lift rod (upper/lower)

After working in wet conditions, make sure to apply grease to the tractor.

## CHECKING AND ADJUSTING STEERING WHEEL

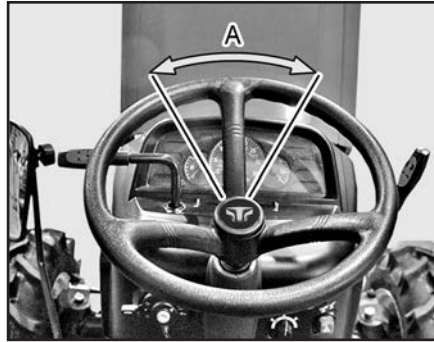

(A) Free play of steering wheel

When the steering wheel is turned to the left and right lightly, there should be free play for 0.8 - 2.0 in. (20 - 50 mm). If the extent of the free play exceeds this range, the steering wheel may feel heavy or the tractor may not move straight. If the free play is not normal, have it fixed at your nearest authorized dealer.



### WARNING

- Check if the steering wheel vibrates severely or has no free play.

## CHECKING AND ADJUSTING BRAKE

[MEC. MODEL]

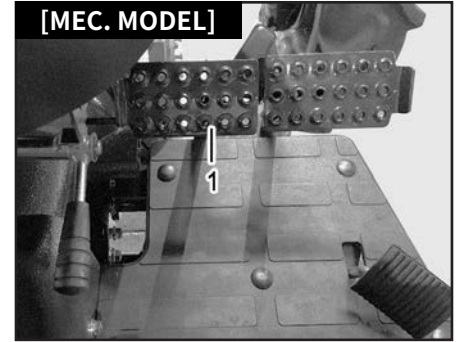

[HST MODEL]

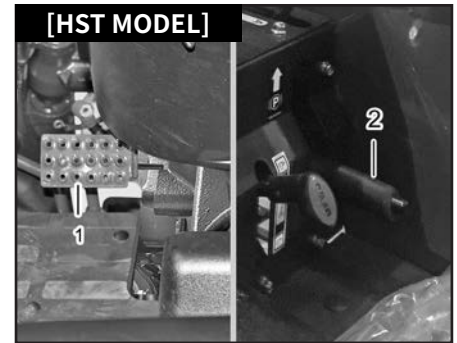

(1) Brake pedal (free play: 5 - 10 mm)  
(2) Parking brake lever

## CHECKING FUEL FILTER WATER SEPARATOR

The free play of the brake pedal is 5 - 10 mm. Adjust both brake pedals at the same time.

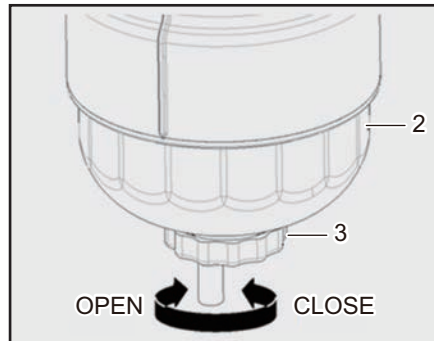
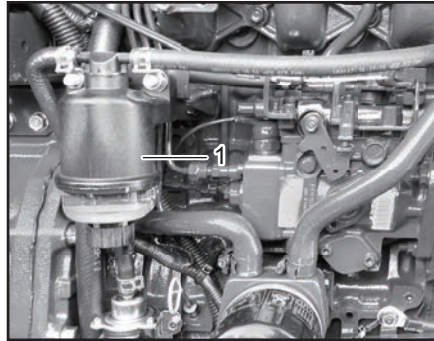

(1) Fuel filter  
(3) Drain plug

(2) Filter head

If moisture is found in the filter head, remove the foreign matter as follows.

- (1) Turn off the starter to prevent air from entering the fuel system.
- (2) Prepare a container to receive the water separator.
- (3) Loosen the drain plug at the bottom of the filter head counterclockwise and let the water drain.
- (4) After the proper amount of fuel has been drained, manually lock the drain valve in the clockwise direction.
- (5) Do not use tools etc. at this time.

## CHECKING EXHAUST GAS

Exhaust gas may be a little black at the time of starting the engine, but normally it is colorless.

- Black: Incomplete combustion due to too much fuel intake
- White: Burning of engine oil

If the temperature is low, water vapor may look white.

If the color of the exhaust gas remains black or white during operation, have the tractor inspected at your nearest authorized dealer.

## CHECKING FUSE AND FUSIBLE LINK

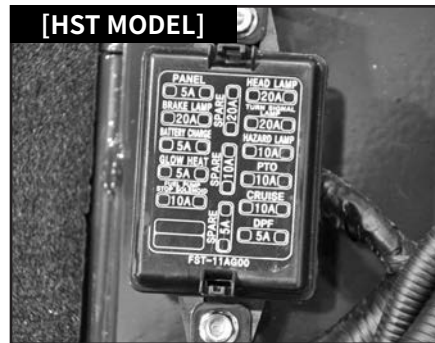
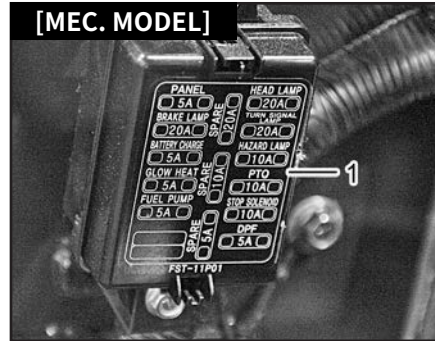

(1) Fuse box

When replacing the fuse, use only the one with the specified capacity. Open the fuse box cover and check the fuses. Replace any blown fuses with new ones of required capacity. Stop the engine and check the main fuses (Fusible link).

If it is blown again, have the tractor inspected at the authorized dealer.

### CAUTION

- When replacing the fuse, use only the one of the specified capacity.



## CHECKING AND ADJUSTING TOE-IN

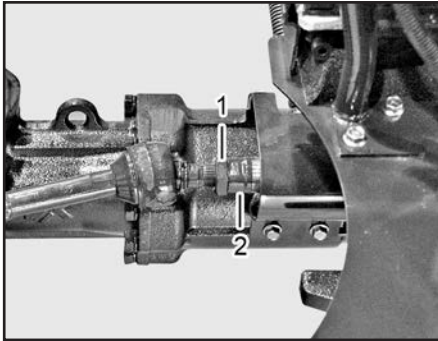

(1) Mounting nut (2) Cylinder rod

If the toe-in is not properly aligned, the steering wheel may be uncontrollable or the tractor may produce an abnormal vibration.

Measure the distance A and the distance B of the front wheels and see if the front one is narrower than rear one by 0.2- 0.3 in. (4 - 8 mm).

If not, loosen the mounting nuts at the end of the cylinder rod on both sides and adjust the length of the screws.

Tighten the nuts when the toe-in is 0.2 -

0.3 in. (4 - 8 mm). Be sure of both lengths of the left and right tie rod ends are the same.

## CHECKING AND ADJUSTING FAN BELT

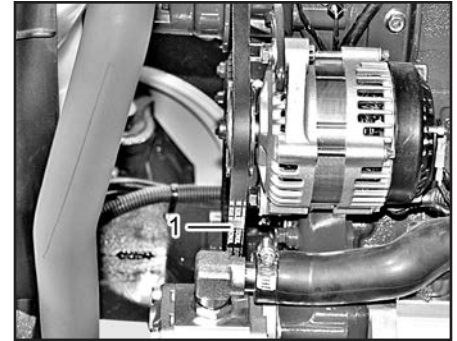

(1) Fan belt

Loosen the generator mounting bolts and move the generator to adjust the tension of the fan belt.

If the fan belt still slips after the generator is moved to the maximum, replace the belt with a new one.

New belts must be inspected after 50 hours of running.



**CAUTION**

- Carry out inspection or maintenance after the engine is fully cooled down.

If this instruction is ignored, you may get burnt.

# 7. TROUBLESHOOTING

TRUBLESHOOTING - ENGINE.....	7-2
TRUBLESHOOTING - CLUTCH AND BRAKE .....	7-5
TRUBLESHOOTING - HYDRAULIC SYSTEM .....	7-6
TRUBLESHOOTING - ELECTRICAL SYSTEM .....	7-7

## TROUBLESHOOTING - ENGINE

Symptom	Inspection item	Action
1. The starter motor does not start when the ignition switch is turned to "START".	• Is the clutch depressed?	• Depress the clutch pedal fully and turn the ignition switch to the "START" position.
	• Is the battery discharged?	• Charge the battery.
	• Is the battery terminal loosened or corroded?	• Clean and tighten the terminals.
	• Is the main fuse blown out?	• Replace the fuse.
	• Is the ignition switch broken?	• Contact the dealer for repair or replacement.
	• Is the starter motor damaged?	• Contact the dealer for repair or replacement.
2. The starter motor runs, but the engine does not start.	• Is the fuel tank empty?	• Fill up the fuel tank and bleed the system.
	• Is the fuel mixed with air?	• Bleed the fuel system.
3. The engine revolution is irregular.	• Is air mixed in the fuel system?	• Bleed the fuel system.
	• Is water mixed in the fuel?	• Drain water and replace fuel.
	• Is the injection nozzle clogged?	• Contact the dealer for repair or replacement.
	• Is the fuel filter clogged?	• Clean or replace it.

Symptom	Inspection item	Action
4. The engine is overheated.	• Is the coolant level low?	• Refill the coolant.
	• Is the fan belt loosened or damaged?	• Adjust the belt tension or replace it.
	• Is the radiator fin clogged?	• Clean it.
	• Is the engine oil level low?	• Refill the engine oil.
	• Is the engine running under overload?	• Reduce the load.
5. The engine power is too weak.	• Is the air cleaner clogged?	• Inspect the air cleaner and replace the element.
	• Is the nozzle damaged?	• Contact the dealer for repair.
	• Is the compression force weak?	• Contact the dealer for repair.
	• Is the valve clearance adjusted properly?	• Contact the dealer for repair.
	• Is the injection timing incorrect?	• Contact the dealer for repair.

Symptom	Inspection item	Action
6. The coolant warning lamp was turned "ON" during operation.	<ul style="list-style-type: none"> <li>• Is the coolant level in the reservoir tank low?</li> </ul>	<ul style="list-style-type: none"> <li>• Refill the coolant.</li> </ul>
7. The engine oil pressure lamp is turned "ON" during operation.	<ul style="list-style-type: none"> <li>• Is the engine oil level low?</li> </ul>	<ul style="list-style-type: none"> <li>• Refill the engine oil up to required level.</li> </ul>
	<ul style="list-style-type: none"> <li>• Is the viscosity of the engine oil low?</li> </ul>	<ul style="list-style-type: none"> <li>• Replace the engine oil with proper viscosity.</li> </ul>
	<ul style="list-style-type: none"> <li>• Is the pressure switch defective?</li> </ul>	<ul style="list-style-type: none"> <li>• Replace the switch.</li> </ul>
	<ul style="list-style-type: none"> <li>• Is the oil pump defective?</li> </ul>	<ul style="list-style-type: none"> <li>• Contact the dealer for repair.</li> </ul>
8. The battery charge warning lamp is turned "ON" during operation.	<ul style="list-style-type: none"> <li>• Is the alternator defective?</li> </ul>	<ul style="list-style-type: none"> <li>• Contact the dealer for repair.</li> </ul>
	<ul style="list-style-type: none"> <li>• Is the fan belt loosened or damaged?</li> </ul>	<ul style="list-style-type: none"> <li>• Adjust the fan belt tension or replace it.</li> </ul>

## TROUBLESHOOTING - CLUTCH AND BRAKE

Symptom	Inspection item	Action
1. The clutch slips or does not be disengaged.	<ul style="list-style-type: none"> <li>• Is the free play of clutch pedal proper?</li> </ul>	<ul style="list-style-type: none"> <li>• Adjust the free play of the pedals.</li> </ul>
2. The brake does not work or works only on one side.	<ul style="list-style-type: none"> <li>• Is the free play of the brake pedals proper?</li> </ul>	<ul style="list-style-type: none"> <li>• Adjust the free play of the pedals.</li> </ul>
3. The brake pedal does not return to its original position properly and it makes a noise.	<ul style="list-style-type: none"> <li>• Is the brake pedal return spring damaged?</li> </ul>	<ul style="list-style-type: none"> <li>• Replace the spring.</li> </ul>
	<ul style="list-style-type: none"> <li>• Is each sliding part well greased?</li> </ul>	<ul style="list-style-type: none"> <li>• Remove the rust and apply grease.</li> </ul>

## TROUBLESHOOTING - HYDRAULIC SYSTEM

Symptom	Inspection item	Action
1. The implement does not be lifted.	• Is the hydraulic flow control dial in the close position?	• Adjust the hydraulic flow control dial.
	• Is the transmission oil level low?	• Refill the transmission oil.
	• Is the air taken in the fluid suction system?	• Tighten the filter or connection parts. Replace the pipe or O-ring if damaged.
	• Is the oil filter clogged?	• Clean or replace it.
	• Is the Selective control valve lever in the detent position?	• Put the Selective control valve lever in the neutral position.
	• Is the hydraulic pump defective?	• Contact the dealer for repair.
	• Is the cylinder damaged?	• Contact the dealer for repair.
2. The implement does not be lowered.	• Is the hydraulic flow control dial in the close position?	• Adjust the hydraulic flow control dial.
	• Is the position control lever on the lowest position?	• Move the position control lever.
	• The implement cannot be lowered even though the position control lever is placed in the lowest position.	• Contact the dealer for repair.



## TROUBLESHOOTING - ELECTRIC SYSTEM

Symptom	Inspection item	Action
1. The headlamp does not turn "ON".	• Is the bulb blown?	• Replace the bulb.
	• Is the fuse blown?	• Replace the fuse.
	• Is the cable connector separated from the socket?	• Inspect it.
	• Is the contact in a poor condition?	• Inspect and clean the grounding and terminals.
2. The turn signal lamp does not come "ON".	• Is the bulb blown?	• Replace the bulb.
	• Is the fuse blown?	• Replace the fuse.
	• Is the cable connector separated from the socket?	• Inspect it.
	• Is the contact in a poor condition?	• Inspect and clean the grounding and terminals.
3. The other lamp does not turn "ON".	• Is the bulb blown?	• Replace the bulb.
	• Is the fuse blown?	• Replace the fuse.
	• Is the cable in a poor contact?	• Inspect the cable and secure the contact.
	• Is the switch defective?	• Replace the switch.

# MEMO

A series of horizontal dotted lines for writing.

## 8. STORAGE AND DISPOSAL

DAILY STORAGE .....	8-2
LONG-TERM STORAGE.....	8-3
OPERATING TRACTOR AFTER LONG-TERM STORAGE .....	8-6
USAGE AND DISPOSAL .....	8-7

## DAILY STORAGE



After work, clean the tractor and dry the moisture and supply grease into each grease nipple.

Avoid water on electrical parts whenever possible, as it will cause equipment breakdown.

1. Store the tractor after cleaning it. Especially, clean it thoroughly after harrowing or working in a wet field.
2. Be sure to lower the implement.
3. Store it indoors if possible. If it should be kept outside, cover it.

### ⚠ CAUTION

- Unless the battery is removed from the vehicle, make sure to disconnect the negative(-) battery cable. The wiring can be gnawed by rodents, leading to a fire.

4. Remove the battery from the tractor in winter and store it indoors for easy starting.
5. Add anti-freeze to the tractor in winter season in order to prevent the radiator from freezing.
6. Remove the ignition key and store it separately.

### ⚠ DANGER

- When covering the tractor, make sure that the engine or the muffler has fully cooled down.

#### [Otherwise]

There is a risk of fire.

### ⚠ CAUTION

- When carrying out checking, maintenance, or repair, make sure to turn off the engine.

#### [Otherwise]

There is a risk that you may be entangled in the tractor or get injured.

## LONG-TERM STORAGE

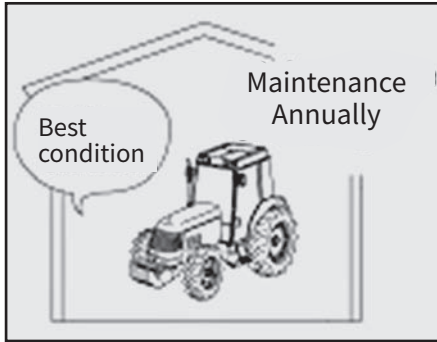

In particular, we recommend that the electrical cables and the rubber hoses, such as fuel hose, steering hoses and radiator hoses, be replaced every two years.

If you carry out maintenance during the off season, you can ensure optimum condition of the tractor as well as safe and comfortable working conditions during the busy season. Also, in order to secure the safety of each part of the tractor and to prevent an accident that may occur due to poor maintenance, arrange with your authorized dealer for periodic maintenance once a year.

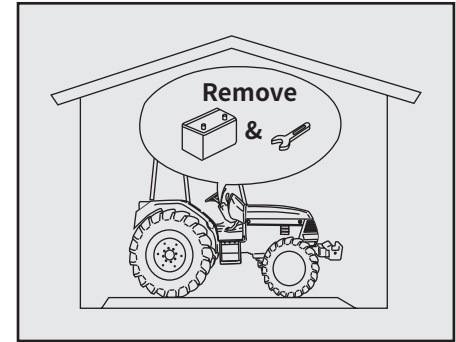

If the tractor is not used for a long time, store it in the following manner.

1. For long storage, put the ignition switch to "OFF".
2. Select a dry and well-drained place for storage. Remove detach the weight & implement or put it down onto the ground.

3. Fill up the fuel tank. Empty space in the fuel tank will produce dewdrops that will produce condensation that will be the cause of rust formation. And lock the fuel cock to "C". (Closed)
4. Disconnect the battery completely and store it away from the tractor in a well-ventilated, dry, dark place if possible. When the battery is attached to the tractor, make sure to connect the (+) terminal first.
5. Change the engine oil and run the engine to circulate oil throughout all the engine parts for about 5 minutes.
6. Drain the coolant from the radiator. After draining the coolant, attach a tag of "No coolant, do not start" to the steering wheel. If there is anti-freeze in the cooling system, it is not necessary to drain it.
7. Check the bolts and nuts for looseness, and tighten if necessary.
8. Add oil, fluid and fuel to each part according to the maintenance chart.
9. Apply a slight coat of grease or oil onto the tractor parts where is easy to be rust such as bare metal surface.
10. Inflate the tires to a pressure a little higher than usual.
11. Place chocks behind and in front of the rear wheels.

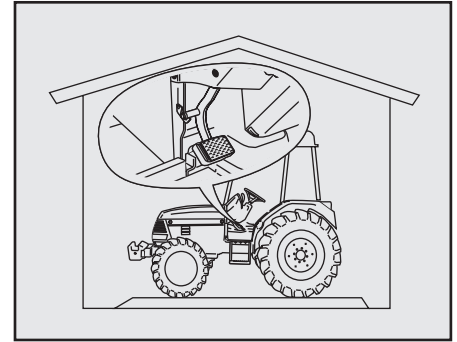

12. Store it in a dry indoor place to avoid rain or snow and cover the body.
13. Keep the clutch pedal in a depressed position to avoid rust on the clutch.
14. Put all controls into the neutral position.

**⊕ IMPORTANT**

- When cleaning the tractor, be sure to stop the engine. Allow sufficient time for the engine to cool before washing.
- Cover the tractor after the muffler and engine have cooled down completely.

**⚠ WARNING**

- Carry out maintenance on a flat and safe place where the tractor will not fall or move and there is no traffic danger. Also, block the front tires to prevent moving of the tractor. Otherwise, there is a risk of accident, such as overturning of the tractor.

**⚠ WARNING**

- Carry out checking and maintenance for each part every year.
- In particular, replace the fuel hoses and the steering hoses every two years. Otherwise, there is a risk of accident or machinery breakdown due to poor maintenance.
- When carrying out checking or maintenance, make sure to stop the engine.
- Replace the covers that have been defected for checking or maintenance.
- Carry out checking or maintenance after heated parts, such as muffler, engine or transmission, have fully cooled down. Otherwise, there is a risk of getting burnt.

**⚠ CAUTION**

To avoid a personal injury,

- Never clean the tractor body while the engine is running.
- Never run the engine in an enclosed area without proper ventilation system in order to prevent poisoning by exhaust gas.
- When storing the tractor, remove the key from the switch and store it separately in order to prevent an unauthorized person from operating the tractor and being injured.

## OPERATING TRACTOR AFTER LONG-TERM STORAGE

Keep the following instructions when operating the tractor after its long-term storage.

1. Perform the inspection procedures before operation.
2. Check the tire air pressure and inflate the tires if it is low.
3. Install a fully charged battery. Check that the battery is fully charged before installing it.
4. Check the fan belt tension.
5. Check all fluid levels. (Engine oil, transmission/hydraulic oil, and engine coolant)
6. Remove grease from the exposed cylinder rod.
7. Apply grease to the lubrication points.
8. Remove the cover from the exhaust pipe.
9. Get onto the tractor and start the engine. To prolong the life and to enhance the performance of the engine, idle the engine for about 30 minutes before starting work.
10. Start the engine, release the parking brake, and check the brake condition by depressing the brake pedal. Adjust the free play of the brake pedals if necessary.
11. Check if the instrument panel and all parts operate correctly while running the engine for a few minutes.
12. Drive the tractor outside and check if it is operating properly. Park the tractor outside and idle the engine for at least 5 minutes. Stop the engine and visually inspect the tractor. Check if there is leakage.
13. Stop the engine and check for leakage. Repair any part as required.



### WARNING

- When operating the tractor in an enclosed area, ventilate the area to release exhaust gas to the outside. Exhaust gas is colorless and not visible, but is harmful.



## USAGE AND DISPOSAL

It is recommended to keep the following to protect the environment:

1. Overload on the machine shortens the product life and increases the harmful exhaust gas which causes air pollution due to the incomplete combustion.
2. When changing the fluid (engine oil, transmission/hydraulic oil, and engine coolant) by yourself, be careful not to spill it and dispose used oil and coolant properly according to the applicable regulations. Otherwise, it can pollute the ground and water.

# MEMO

A series of horizontal dotted lines for writing.