

6225C(EU)(AC02123) TRACTOR

Parts Catalogue



CONTENTS

GROUP NO	GROUP NAME	PAGE
G. ENGINE		
A01_007	CYLINDER BLOCK	6
A02_005	DRIVE PULLY	8
A03_004	CRANK SHAFT PULLEY	10
A04_005	GLOW PLUG ASS'Y OPTION	12
A05_005	CRANK SHAFT ASS'Y OPTION	14
A06_006	BREATHER OPTION	16
A07_005	CAMSHAFT	18
A08_006	ALTERNATOR	20
A09_007	COOLING WATER PUMP	22
A10_008	COOLING FAN SPACER	24
A11_007	INJECTOR	26
A12_014	FUEL INJECTON	28
A13_005	PLUMBING, FUEL	30
A14_003	FUEL FILTER BRACKET	33
A16_003	FUEL FILTER ASS'Y OPTION	35
A17_008	INTAKE MANIFOLD ASS'Y OPTION	37
A18_011	FLYWHEEL	39
A19_009	FLYWHEEL HOUSING	41
A20_011	HEAD, CYLINDER	43
A21_004	HEAD COVER	45
A23_008	TURBOCHARGER SUPPORT ASS'Y OPTION	47
A24_003	TURBOCHARGER	49
A25_003	OIL JET ASS'Y OPTION	51
A26_005	COOLER, ENGINE OIL	53
A27_010	OIL PAN ASS'Y OPTION	55
A28_001	PUMP, LUBRICATING OIL	57
A29_005	FILTER, LUBRICATING OIL	59
A30_003	FRONT GEAR ACCESSORY DRIVE	61
A31_007	PISTON	63
A32_003	LEVER, LOCKER	65
A33_011	EXHAUST MANIFOLD	67
A35_002	IDLE GEAR	69
A36_004	COVER, FRONT GEAR	71
A37_001	BALANCE ASS'Y	73

CONTENTS

GROUP NO	GROUP NAME	PAGE
G. ENGINE		
A38_007	GAUGE, OIL LEVEL	75
A39_001	OIL FILLER CAP	77
A40_003	LIFT ASS'Y OPTION	79
A41_001	COMP,DRIVE PULLEY ASS'Y OPTION	81
A42_003	MOTER, STARTIONS	83
A43_001	DPF SUPPORT OPTION	85
A44_008	DPF MOUNTING OPTION	87
A45_012	DPF	89
A48_006	V-BELT	91
A50_001	COMPRESSOR BRACKET ASS'Y	93
A51_006	INTAKE HOSE ASSY OPTION	95
B. ENGINE ACCESSORIES		
B01010	FUEL TANK	97
B02020	RADIATOR	99
B05011	LEVER ACCELERATOR	101
C. CLUTCH, BREAK, LEVER		
C01030	CLUTCH PEDAL	103
C02010	BRAKE PEDAL	105
C02032	BRAKE LINK	107
C02050	PARKING BRAKE	109
C02051	CABLE, PARKING BRAKE	111
C04010	SHUTTLE ASS'Y	113
C04031	LEVER, MAIN SHIFT	115
C04041	DIFF-LOCK PEDAL	117
C04060	SCV LEVER	119
C04071	LEVER ASS'Y, PTO SPEED CHANGE	121
D. HYDRAULIC		
D01010	HYD PUMP	123
D01020B	LOW PRESSURE PIPE	125
D01040	HYD FILTER	127
D01050	SCV VALVE	129
D02010	STEERING WHEEL	131
D02030	PST HOSE	133
D02040	PST CYLINDER	135

CONTENTS

GROUP NO	GROUP NAME	PAGE
D. HYDRAULIC		
D04000	HYDRAULIC CYLINDER	137
E. FRONT AXLE		
E01010	FRONT AXLE CASE	139
E01013	FRONT AXLE CASE/SPACER	141
E01020	SHAFT COVER	143
E01030	GEAR CASE, FRONT AXLE	145
E01070	FORNT DRIVE SHAFT	147
E01080	TIE ROD	149
F. TRANSMISSION		
F01010	CLUTCH HOUSING	151
F01020	TRANSMISSION CASE	153
F01030	HOUSING, REAR AXLE	156
F02010	CLUTCH RELEASE	158
F02020	CLUTCH SHAFT	160
F02060	REVERSE IDLE SHAFT	162
F02080	CLUTH DISC	164
F03040	RANGE SHIFT DRIVE SHAFT	166
F03050	RANGE SHIFT DRIVEN SHAFT	168
F03060	COUNTER SHAFT	170
F03080	GUIDE SHAFT, MAIN SHIFT	172
F04010	FRONT WHEEL DRIVE SHAFT	174
F04030	FRONT WHEEL DRIVE IDLE SHAFT	176
F05000	DIFFERENTIAL ASS'Y	178
F06030	BRAKE	180
F07000	PTO	182
F07050	PTO VALVE	185
F07120	ROD ASSY, PTO & 4WD	187
F08060	FORK, PTO SHIFT	189
F10020	LIFT ARM	191
F10030	SAFTY VALVE	193
F10040	STOP VALVE	195
F10061	DRAFT/ POSITION CONTROL LEVER	197
F10063	DRAFT CONTROL	199
F10064	POSITION CONTROL LEVER	201

CONTENTS

GROUP NO	GROUP NAME	PAGE
F. TRANSMISSION		
F10120	REAR SCV	203
F11020	FRONT DRIVE & RANGE SHIFT LEVER	205
G. SHEET METAL, CABIN		
G01020	BONNET	207
G01040	LATCHING DEVICE, BONNET	209
G01060A	FIXED BRACKET, BONNET	211
G01080	FRONT AXLE BRACKET	213
G02010	CABIN FRAME	215
G02011	PILLAR COVER	217
G02020	DASH BOARD	219
G02030	SIDE MIRROR	221
G02050	DOOR ASS'Y	223
G02071	FRONT WINDOWS	225
G02072	REAR WINDOWS	227
G02131	ROOF/OUTER	229
G02132	ROOF/INNER	231
G02140	DRIVER'S SEAT	233
G02150	FLOOR MAT	235
G02181	FENDER COVER/LH	237
G02182	FENDER COVER/RH	239
G02190	FENDER ASS'Y	241
G03010	AIR CONDITIONER	243
G03020	A/C DUCT	245
G03080	A.C HOSE/CONDENSER HOSE	247
G03091	COMPRESSOR	249
G05020	TOP LINK	251
G05030	LOWER LINK	253
G05050	LIFT LINK/LH,RH	255
G05070	DRAWBAR	257
H. ELECTRICALS, HARNESS		
H01030	BATTERY	259
H02020	COMBINATION LAMP	261
H03000	HARNESS	263
H04030	INSTRUMENT PANEL	265

CONTENTS

GROUP NO	GROUP NAME	PAGE
H. ELECTRICALS, HARNESS		
H04050	SWITCH	267
H04090	HORN	269
H05040	WASHER LIQUID TANK	271
I. WEIGHT, TOOLS, TIRE		
I01010	FRONT WEIGHT	273
I03000	NAME PLATE	275
I03030	NAME PLATE	277
I05010	FRONT WHEEL&TIRE	279
I05020	REAR WHEEL&TIRE ASSY	281
I07010	SPARE TOOLS	283

A01_007

A2300T3-ETC_5
(AB00333)

CYLINDER BLOCK

Year/Month

2022-12-19

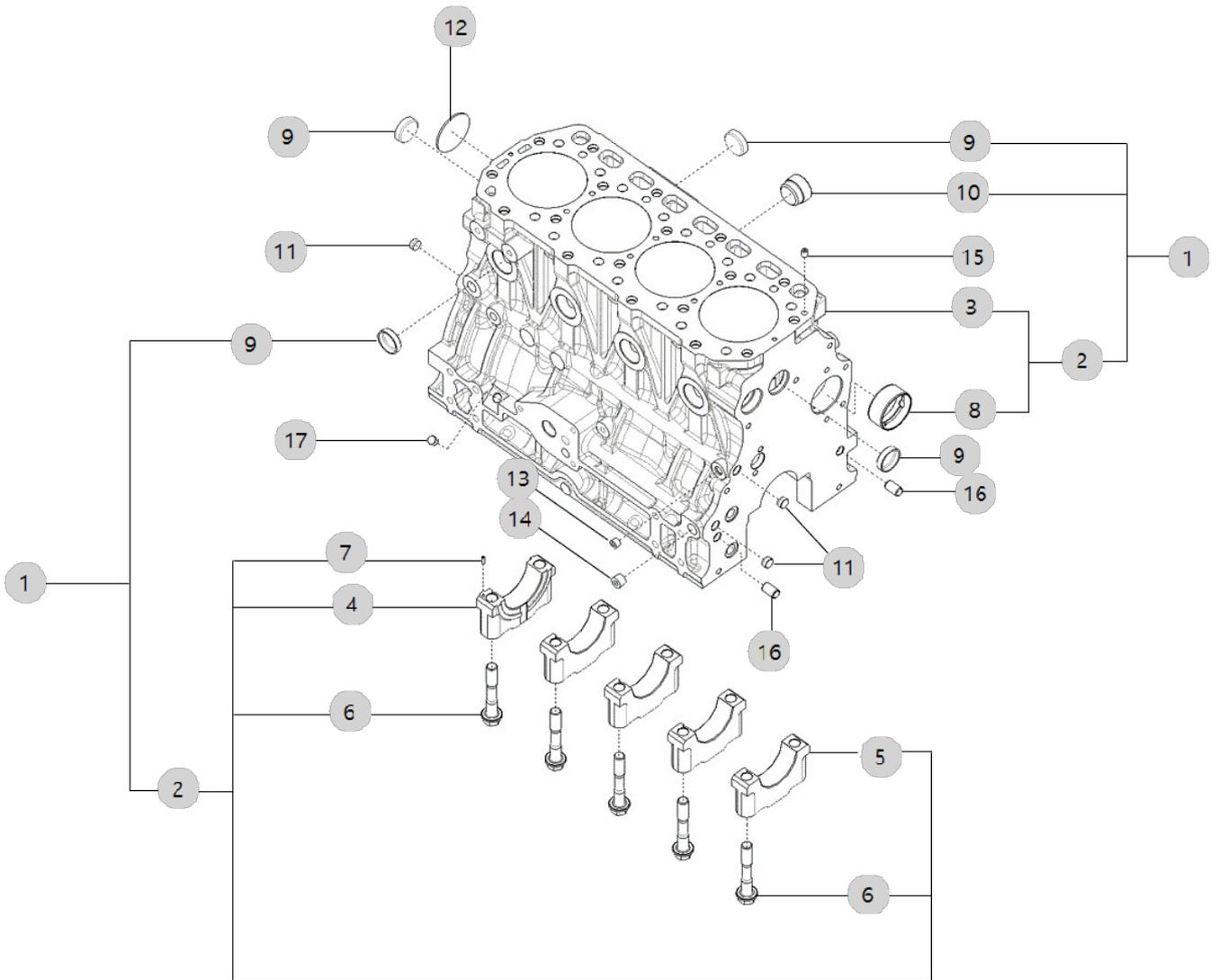

A02_005

A2300T3-ETC_5
(AB00333)

DRIVE PULLY

Year/Month

2022-12-19

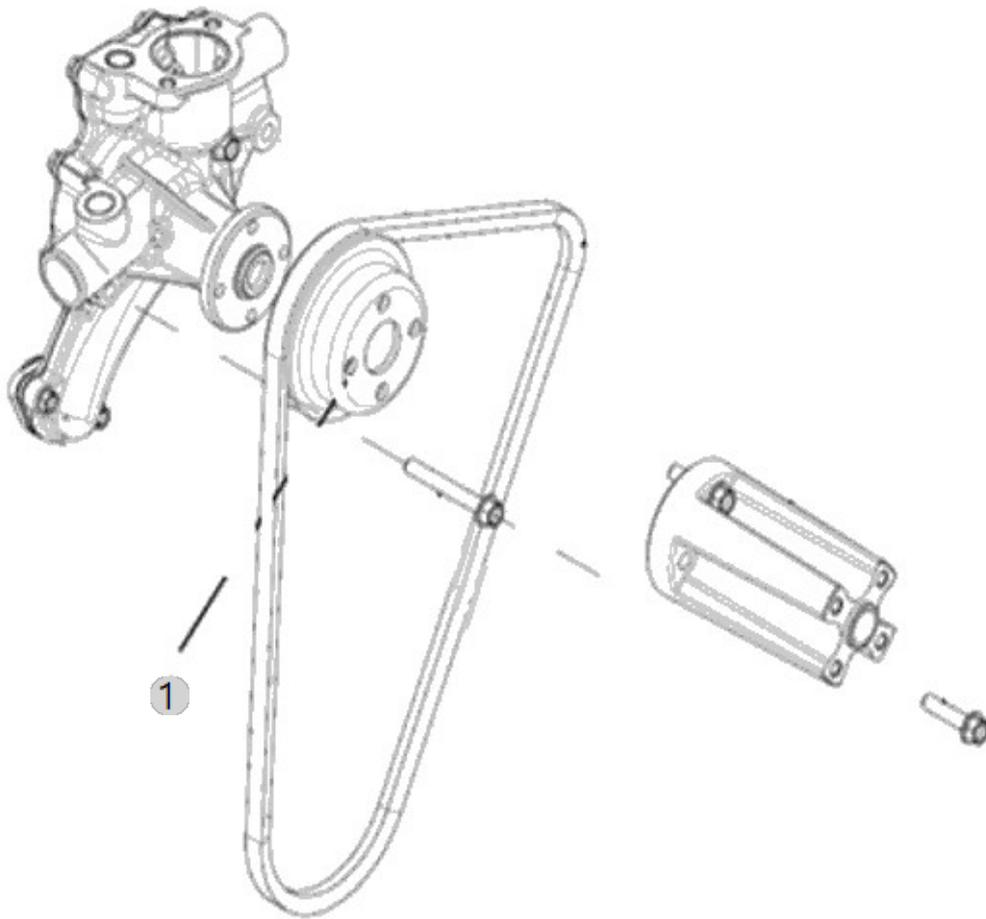

A03_004

A2300T3-ETC_5
(AB00333)

CRANK SHAFT PULLEY

Year/Month

2022-12-19

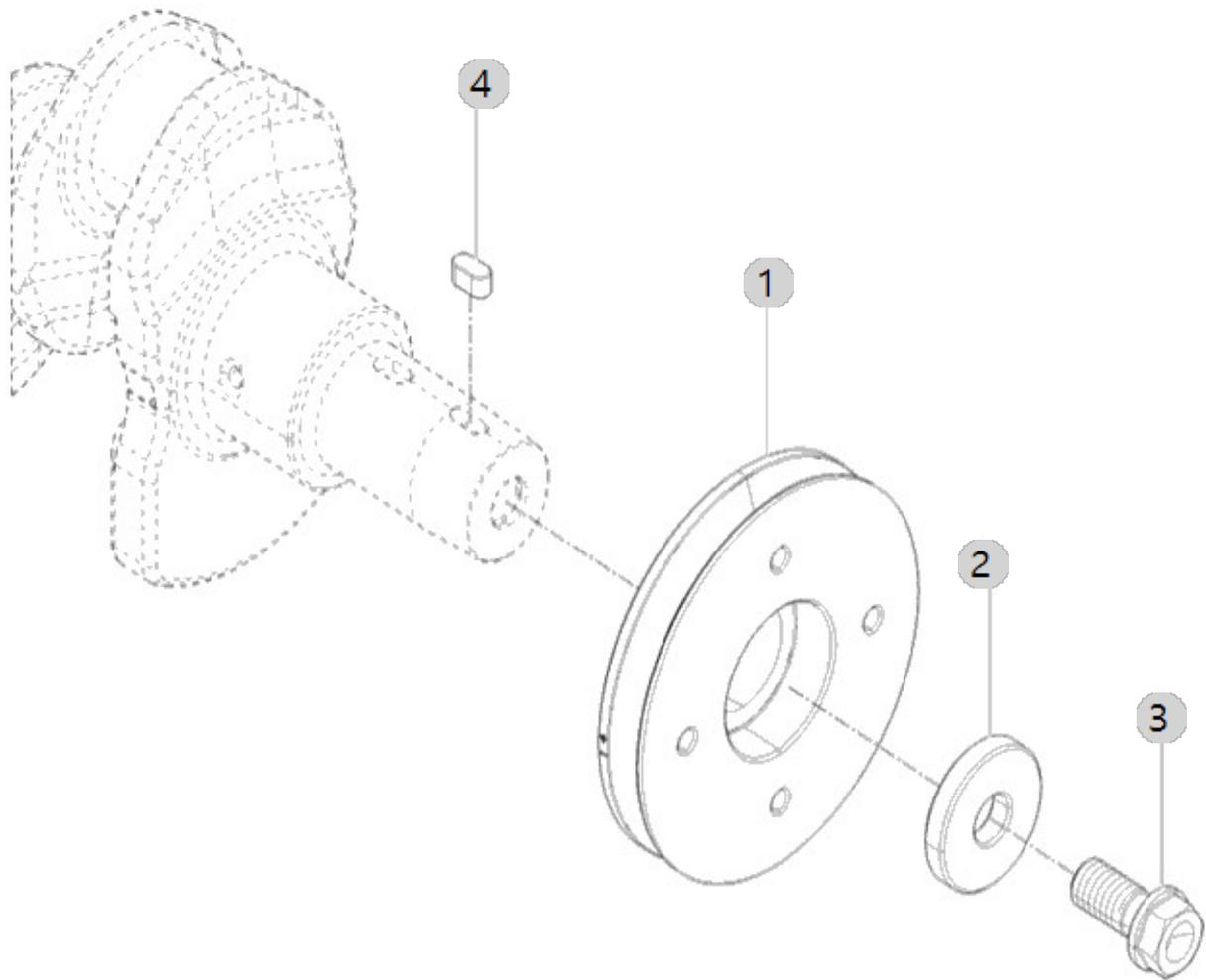

A04_005

A2300T3-ETC_5
(AB00333)

GLOW PLUG ASS'Y OPTION

Year/Month

2022-12-19

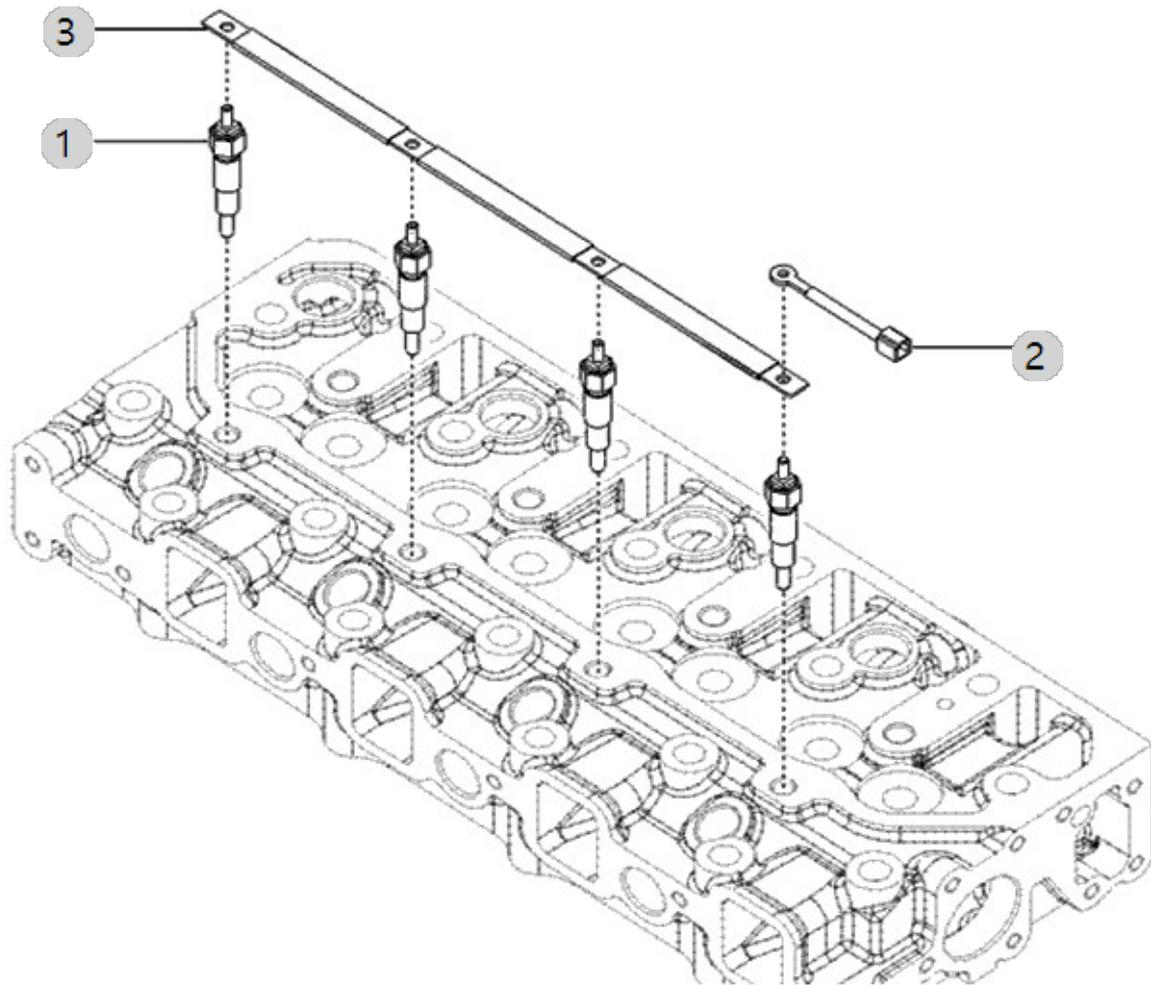

A05_005

A2300T3-ETC_5
(AB00333)

CRANK SHAFT ASS'Y OPTION

Year/Month

2022-12-19

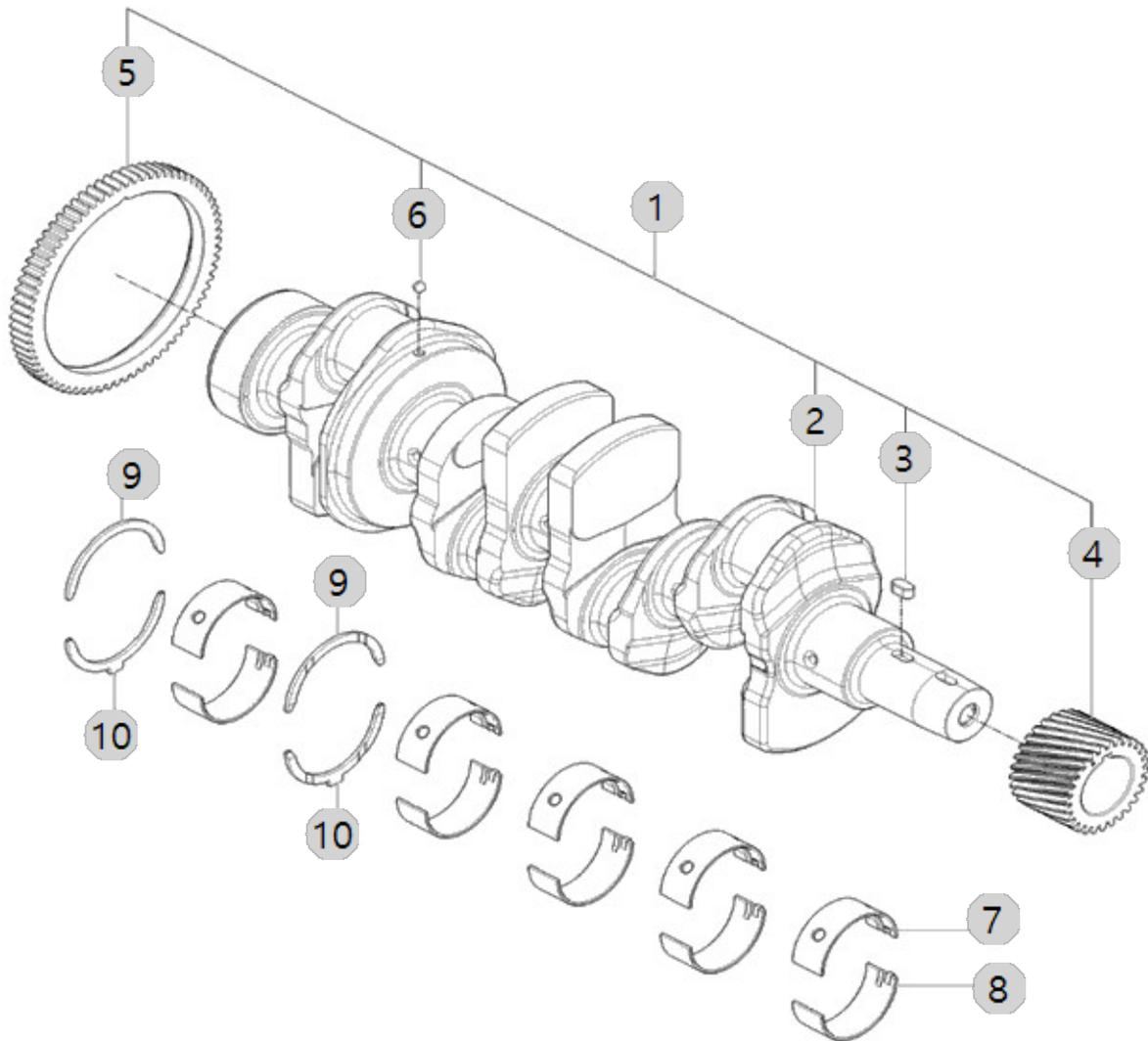

A06_006

A2300T3-ETC_5
(AB00333)

BREATHER OPTION

Year/Month

2022-12-19

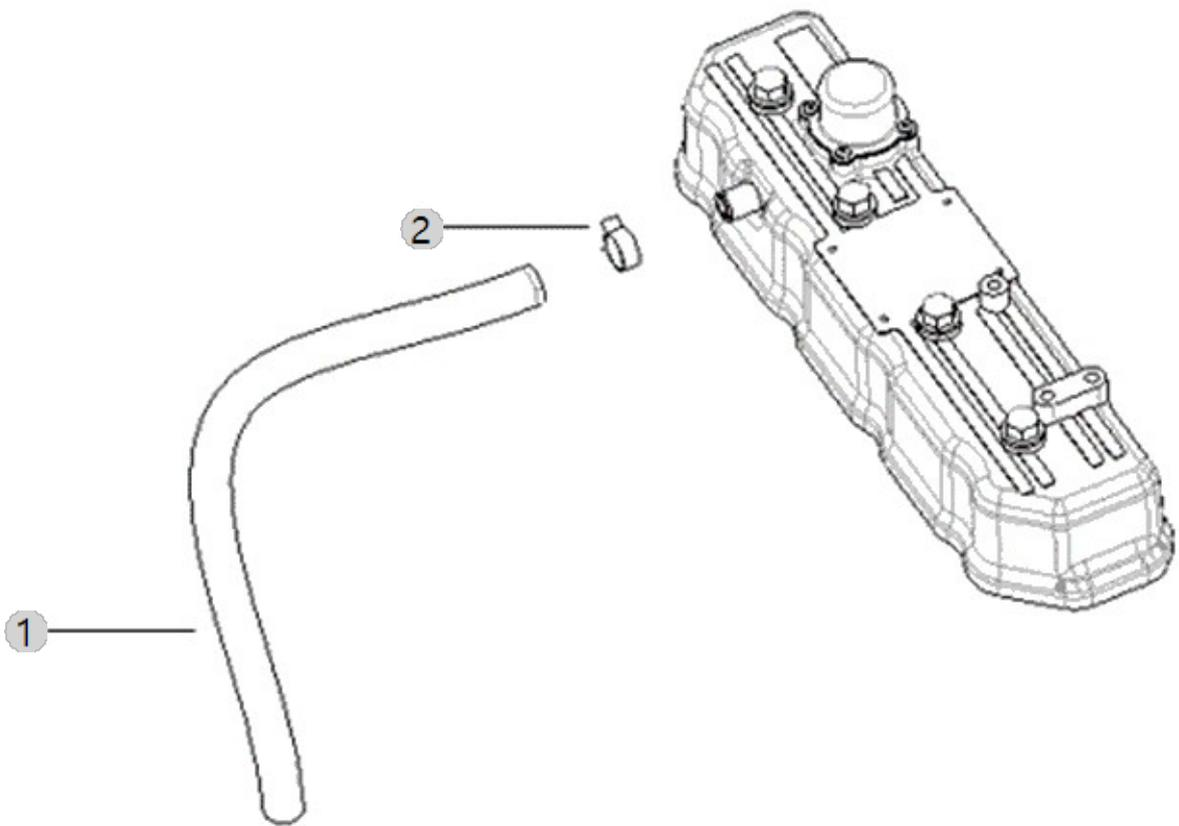

A07_005

A2300T3-ETC_5
(AB00333)

CAMSHAFT

Year/Month

2022-12-19

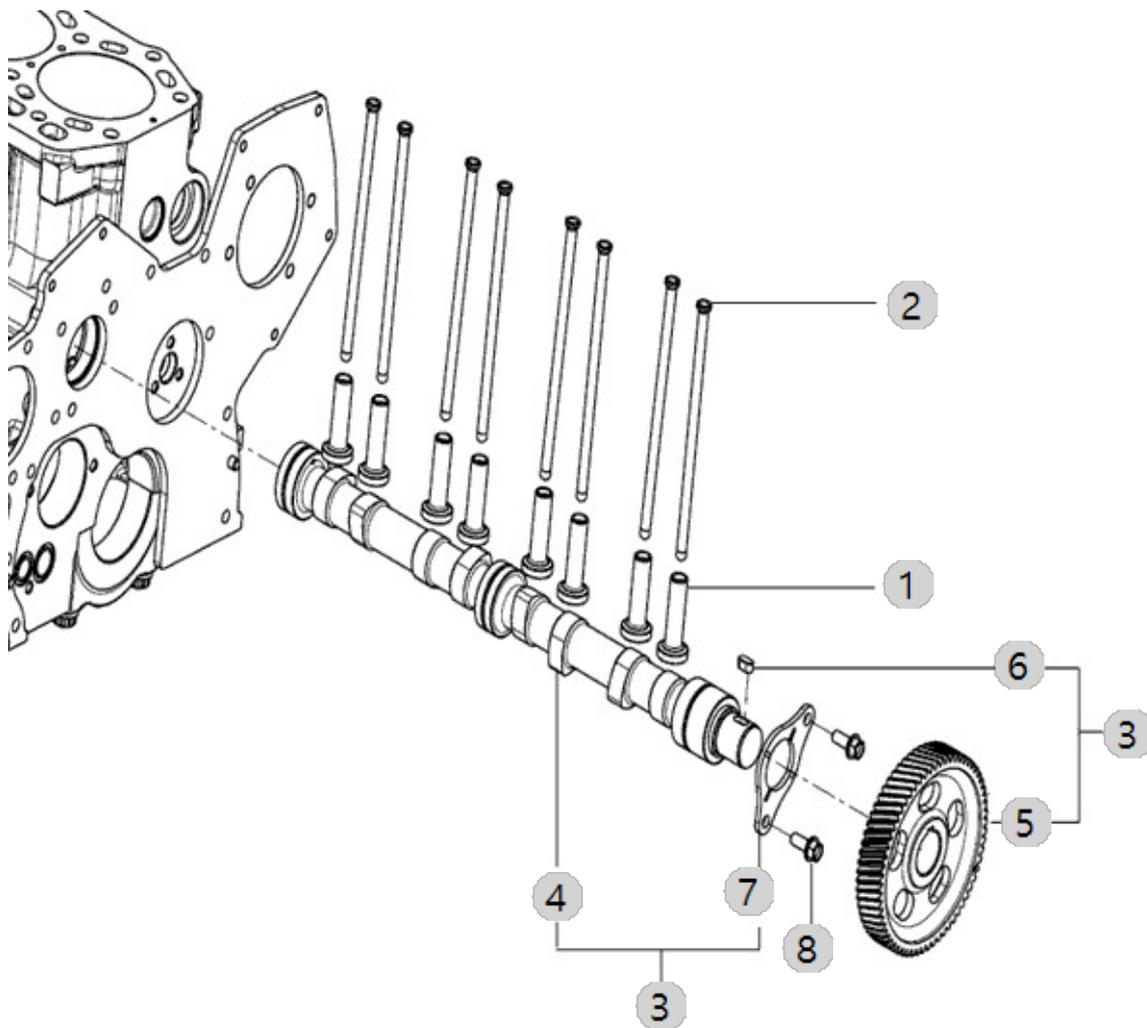

A08_006

A2300T3-ETC_5
(AB00333)

ALTERNATOR

Year/Month

2022-12-19

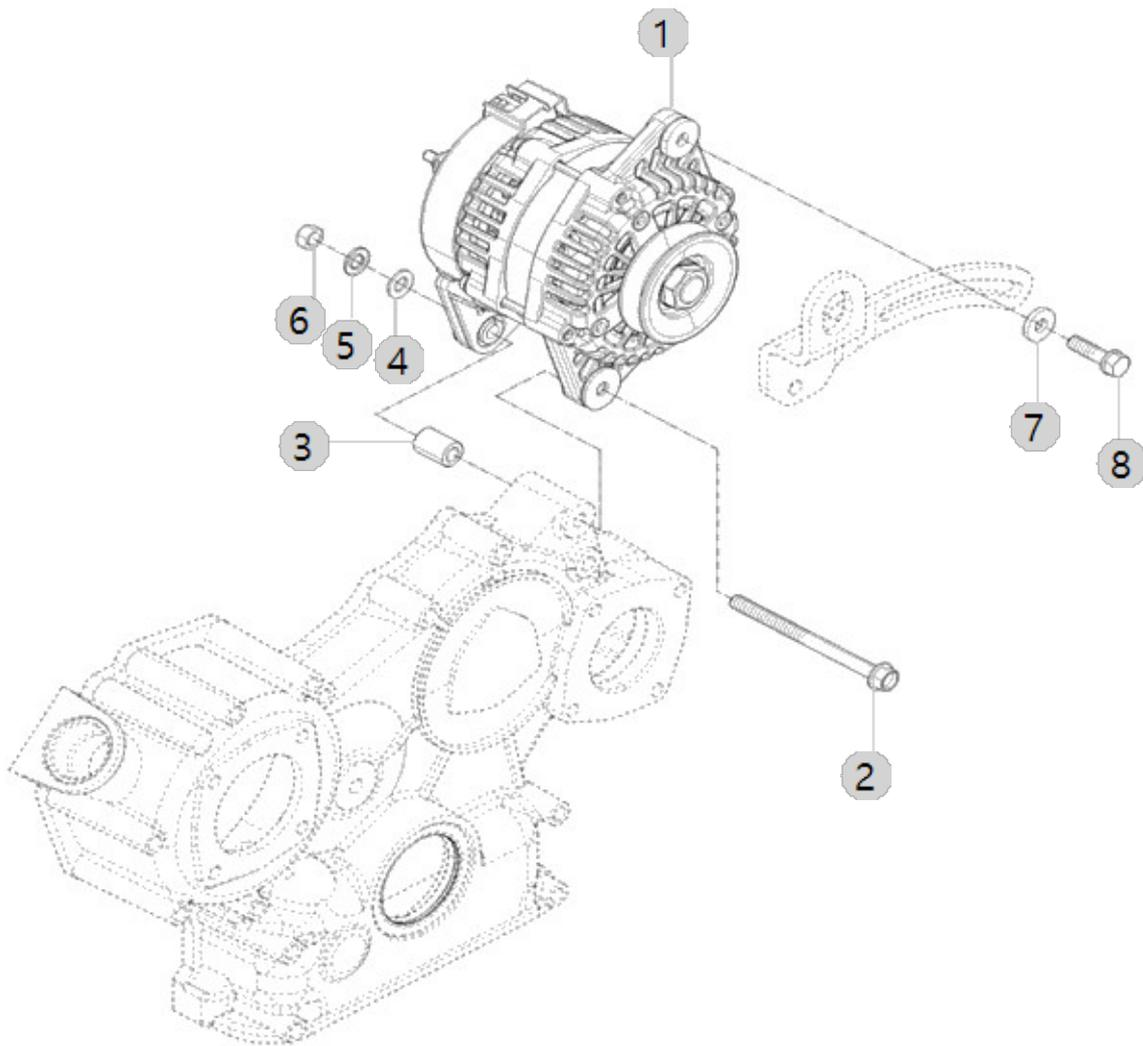

A09_007

A2300T3-ETC_5
(AB00333)

COOLING WATER PUMP

Year/Month

2022-12-19

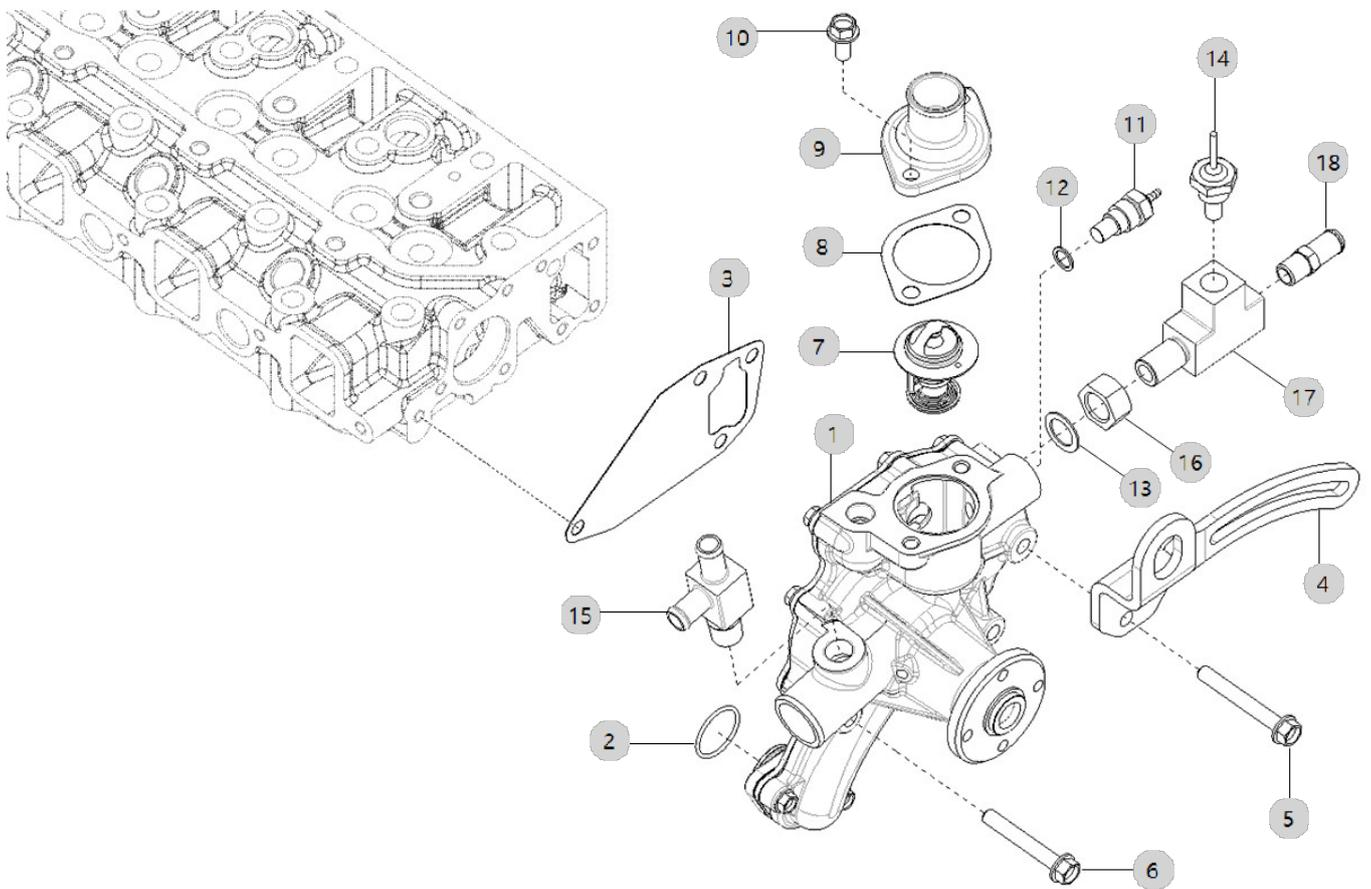

A10_008

A2300T3-ETC_5
(AB00333)

COOLING FAN SPACER

Year/Month

2022-12-19

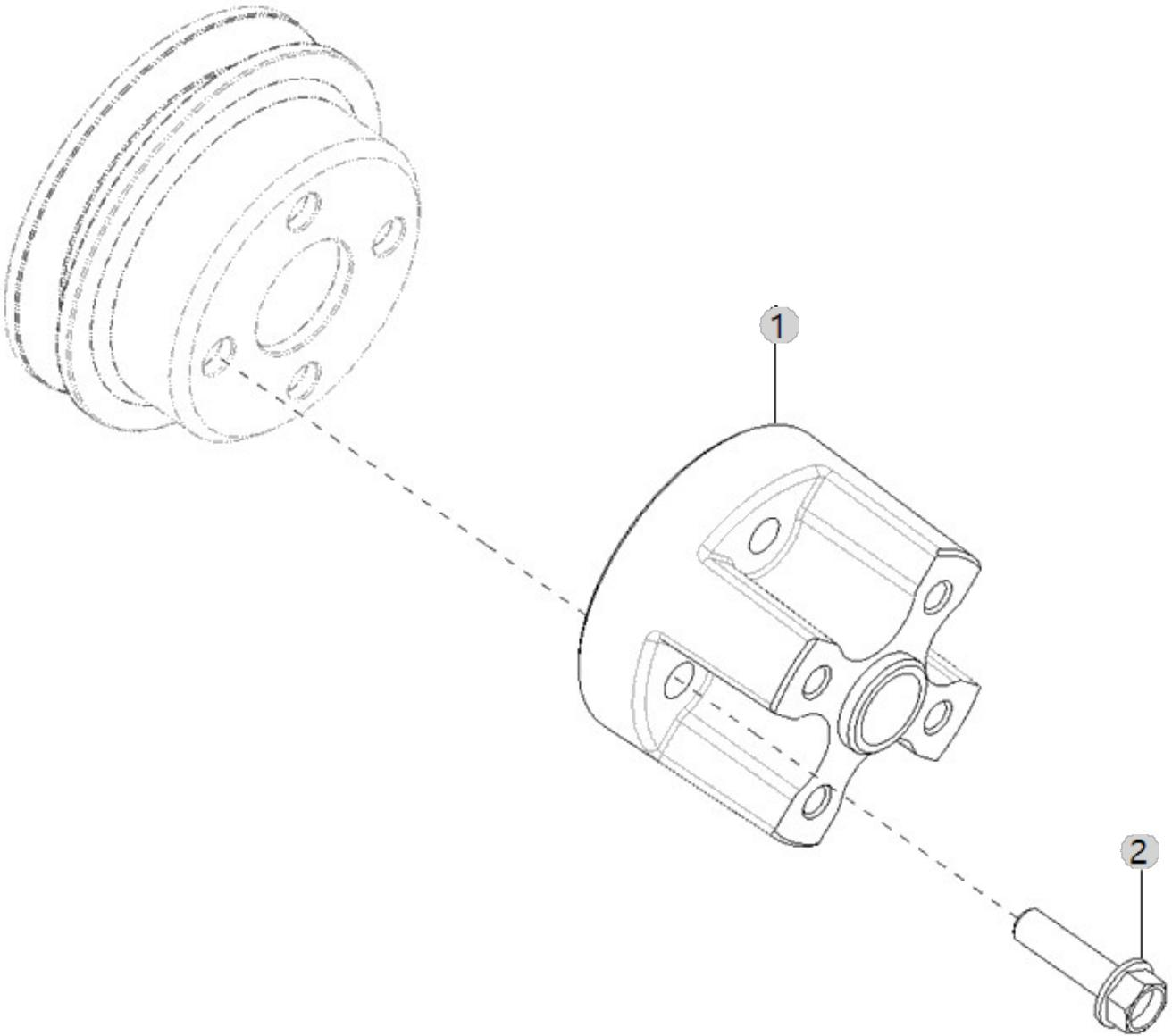

A11_007

A2300T3-ETC_5
(AB00333)

INJECTOR

Year/Month

2022-12-19

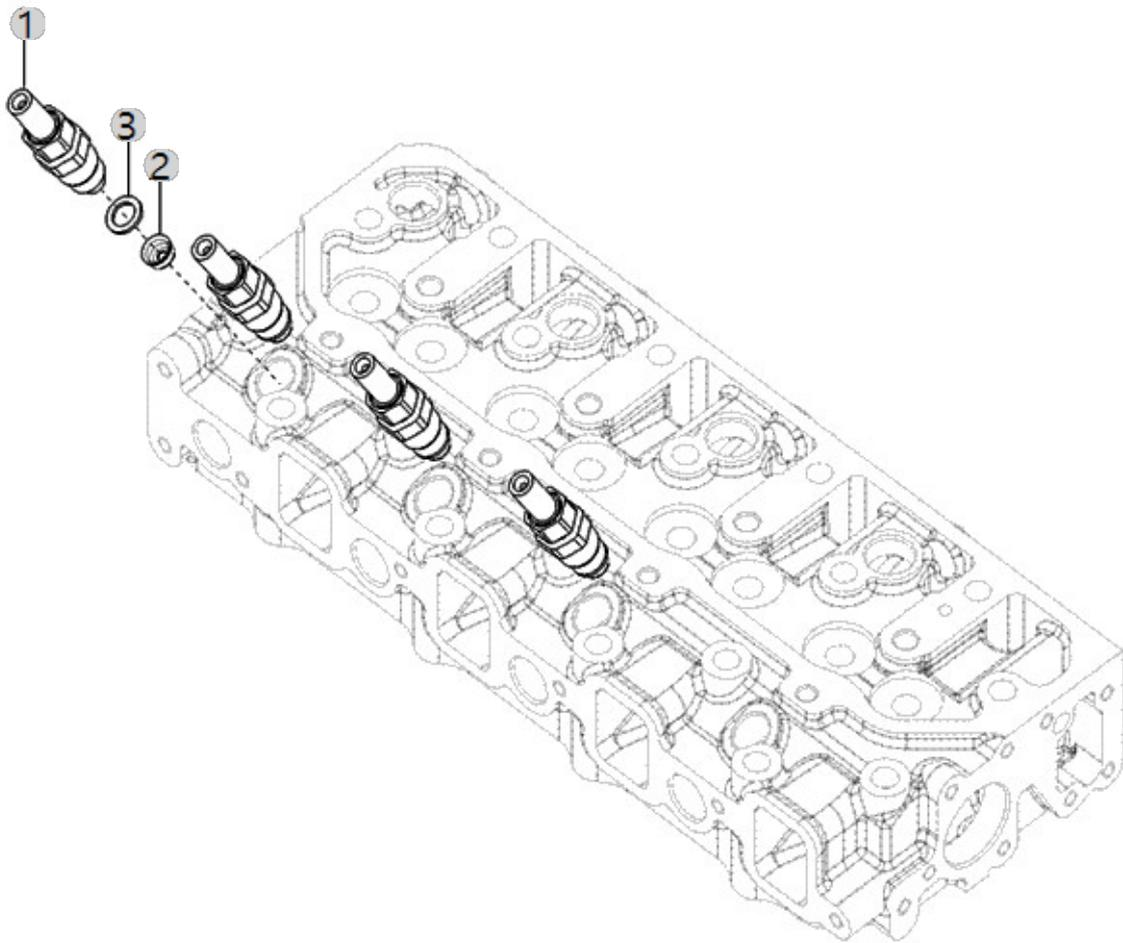

A12_014

A2300T3-ETC_5
(AB00333)

FUEL INJECTOR

Year/Month

2022-12-19

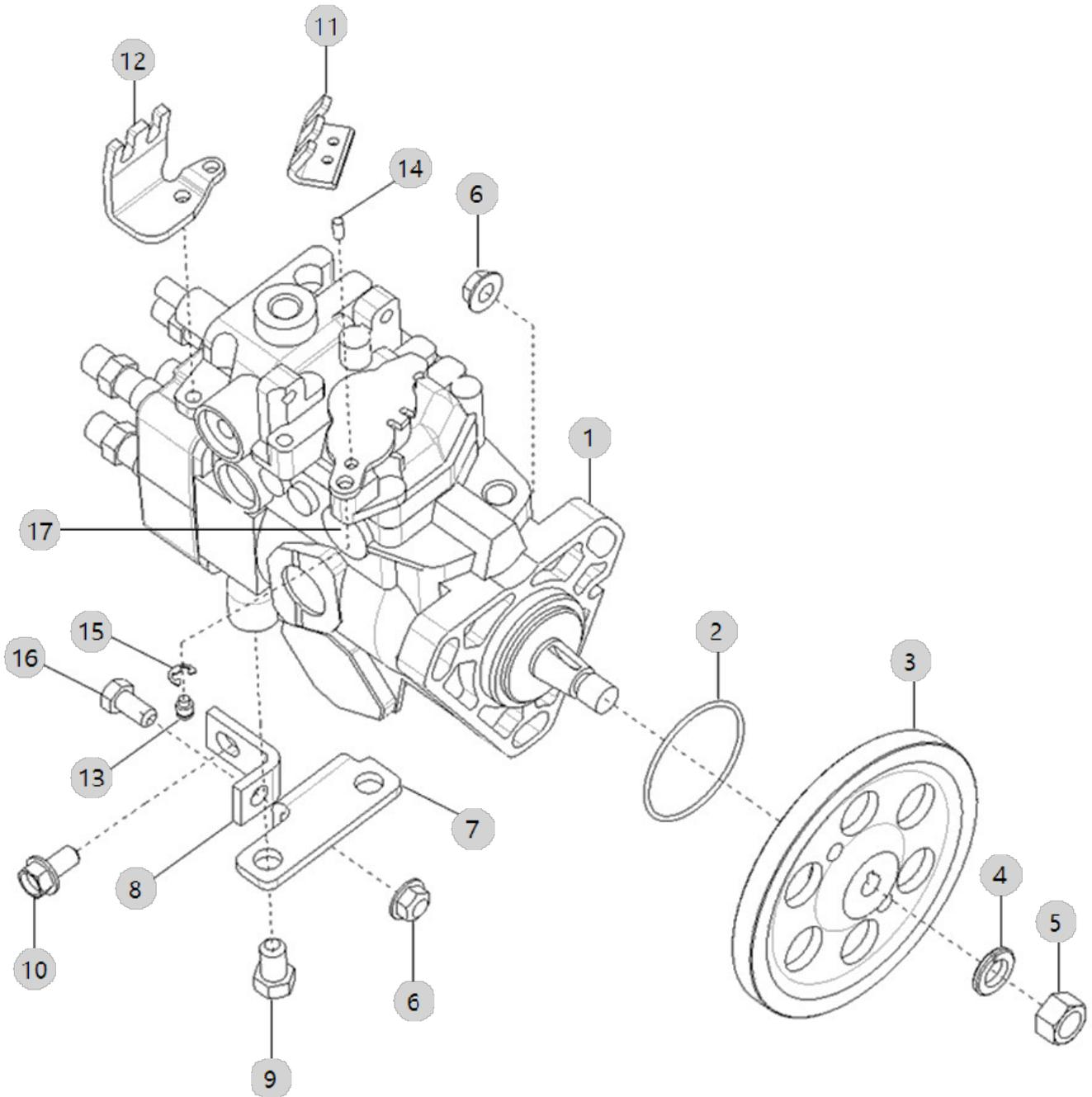

A12_014 A2300T3-ETC_5 (AB00333)		FUEL INJECTON				Year/Month 2022-12-19
순번 (NO)	부품번호 (PART NO)	품명 (PART NAME)	품명 (PART NAME)	수량 (QTY)	규격 (SPEC)	비고 (REMARK)
1	EA00002882B	연료분사펌프조합	FUEL INJECTION PUMP	1		
1	EA00002882A	연료분사펌프조합 - 트랙	FUEL INJECTION PUMP	1		
2	24311-000500	O링	O-RING, DYNAMIC (Φ50)	1	P50	
3	HRA070080DB3	연료분사펌프기어	GEAR,FUELPUMP	1		
3	HRA070080DC3	연료분사펌프기어	GEAR,FUEL PUMP	1		
4	22217-120000	스프링와셔	WASHER, SPRING (Φ 12)	1	M12	
5	26716-120002	295,ALL,육각너트	HEXA NUT295	1	M12X1.75	
6	26367-080002	259, 육각플랜지너트	HEX FLANGE NUT (Φ8)	4	M8XP1.25	
7	HRA130020DB4	VE지지브라켓(A)	BRACKET,PUMP	1	T 4.5	
7	HRA130020DA4	296,A202322,VE지지브라켓(A)	BRACKET(B),PUMP	1	T 4.5	
8	HRA130030DB4	VE지지브라켓(B)	BRACKET,PUMP	1	T 4.5	
8	HRA130030DA4	297,A202322,VE지지브라켓(B)	BRACKET(A),PUMP	1	T 4.5	
9	26116-100162	육각보울트	SCREW,HEXAGONHEADCAP	2	M10X1.5X16	
10	26106-080162	플랜지볼트8X16	SCREW,HEXFLANGEHEADCAP	1	M8XP1.25X16	
11	EA00004970B	후크-엑셀레버	LEVER, HOOK,ACCEL	1		
11	EA00004970A	후크-엑셀레버	LEVER, HOOK,ACCEL	1		
12	EA00006027A	써포트(엑셀레버)	SUPPORT(ACCELERATOR LEVER)	1	T4.0	
12	EA00006027B	써포트(엑셀레버)	SUPPORT(ACCELERATOR LEVER)	1	T4.0	
13	HRA1300702A9	고정핀	PIN	1		
14	EA00002103A	핀	PIN	1	N4	
15	22272-000050	E형스냅링5	RING, CIRCLIP (Φ 05)	1	D5	
16	26116-080162	육각볼트	SCREW,HEXAGONHEADCAP	1	M8X1.25X16	
17	EA00003768A	픽업센서	PICKUP SENSOR	1		

A13_005

A2300T3-ETC_5
(AB00333)

PLUMBING, FUEL

Year/Month

2022-12-19

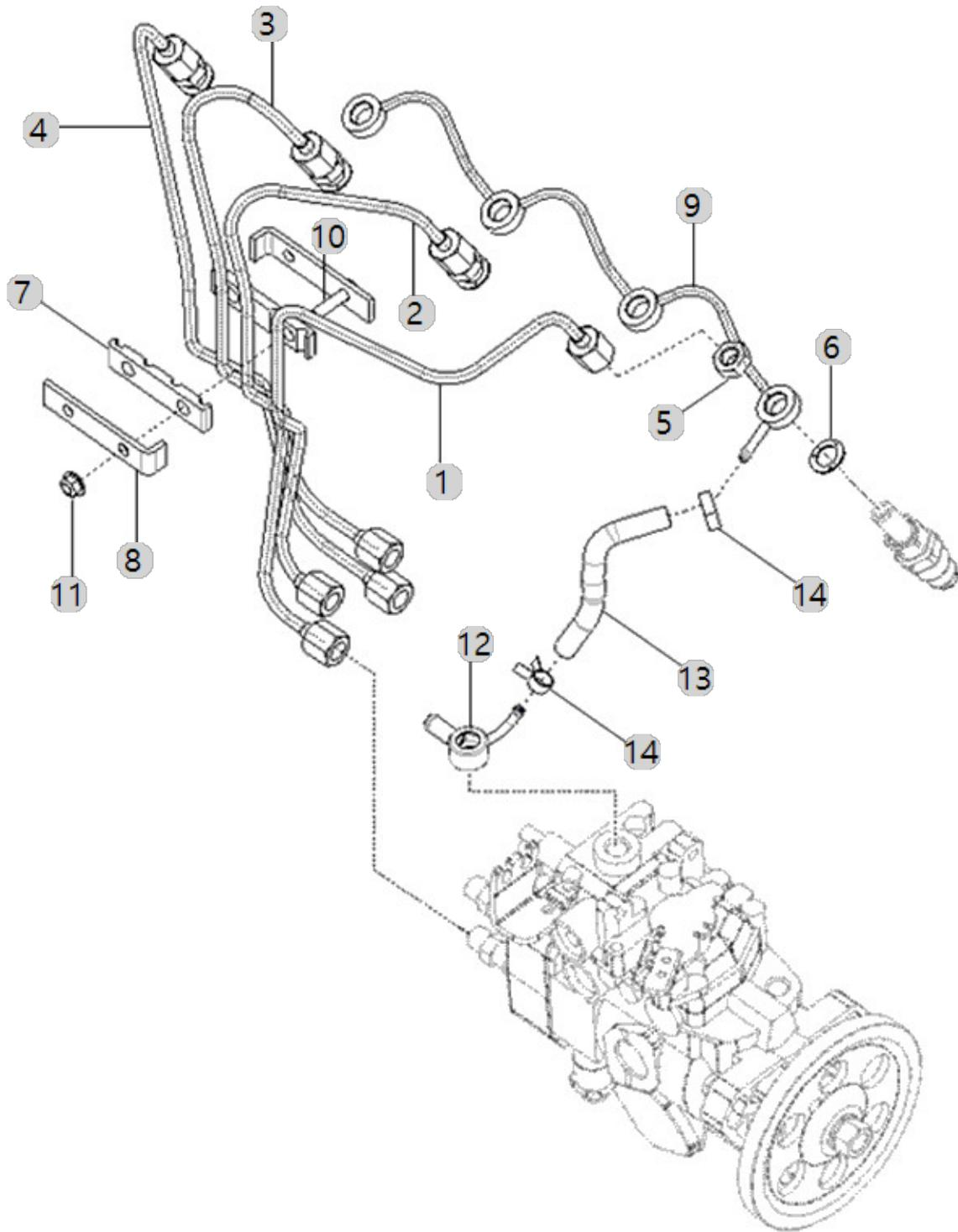

A13_005 A2300T3-ETC_5 (AB00333)		PLUMBING, FUEL				Year/Month 2022-12-19
순번 (NO)	부품번호 (PART NO)	품명 (PART NAME)	품명 (PART NAME)	수량 (QTY)	규격 (SPEC)	비고 (REMARK)
1	HRA150050DB0	299,A202322,연료파이프조합(A)	PIPE ASSY, FUEL SUPPLY A	1		
1	HRA150050DB0	299,A202322,연료파이프조합(A)	PIPE ASSY, FUEL SUPPLY A	1		
1	HRA150050DB0	299,A202322,연료파이프조합(A)	PIPE ASSY, FUEL SUPPLY A	1		
1	HRA150050DC0	연료파이프조합(A)	TUBE,INJECTOR FUEL SUPPLY	1		
2	HRA150060DB0	300,A202322,연료파이프조합(B)	PIPE ASSY, FUEL SUPPLY (B)	1		
2	HRA150060DB0	300,A202322,연료파이프조합(B)	PIPE ASSY, FUEL SUPPLY (B)	1		
2	HRA150060DC0	연료파이프조합(B)	TUBE,INJECTOR FUEL SUPPLY	1		
2	HRA150060DB0	300,A202322,연료파이프조합(B)	PIPE ASSY, FUEL SUPPLY (B)	1		
3	HRA150070DC0	연료파이프조합(C)	TUBE,INJECTOR FUEL SUPPLY	1		
3	HRA150070DB0	301,A202322,연료파이프조합(C)	PIPE ASSY, FUEL SUUPPLY C	1		
3	HRA150070DB0	301,A202322,연료파이프조합(C)	PIPE ASSY, FUEL SUUPPLY C	1		
3	HRA150070DB0	301,A202322,연료파이프조합(C)	PIPE ASSY, FUEL SUUPPLY C	1		
4	HRA150080DB0	302,A202322,연료파이프조합(D)	PIPE ASSY, FUEL SUPPLY D	1		
4	HRA150080DC0	연료파이프조합(D)	TUBE,INJECTOR FUEL SUPPLY	1		
4	HRA150080DB0	302,A202322,연료파이프조합(D)	PIPE ASSY, FUEL SUPPLY D	1		
4	HRA150080DB0	302,A202322,연료파이프조합(D)	PIPE ASSY, FUEL SUPPLY D	1		
5	HK13450000A4	육각고정너트	NUT,REGULARHEXAGON	4	M12X1.5	
5	HK13450000A4	육각고정너트	NUT,REGULARHEXAGON	4	M12X1.5	
5	HK13450000A4	육각고정너트	NUT,REGULARHEXAGON	4	M12X1.5	
5	HK13450000A4	육각고정너트	NUT,REGULARHEXAGON	4	M12X1.5	
6	HK13440000A4	306,ALL,패킹(조인트)(와류실)	GASKET,FUELMANIFOLD	4		
6	HK13440000A4	306,ALL,패킹(조인트)(와류실)	GASKET,FUELMANIFOLD	4		
6	HK13440000A4	306,ALL,패킹(조인트)(와류실)	GASKET,FUELMANIFOLD	4		
6	HK13440000A4	306,ALL,패킹(조인트)(와류실)	GASKET,FUELMANIFOLD	4		
7	HRA1502700A4	462,ALL,브래킷고무	RUBBER,BRACKET	2		
7	HRA1502700A4	462,ALL,브래킷고무	RUBBER,BRACKET	2		
7	HRA1502700A4	462,ALL,브래킷고무	RUBBER,BRACKET	2		
7	HRA1502700A4	462,ALL,브래킷고무	RUBBER,BRACKET	2		
8	HRA1502800A4	브래킷판	CLAMP,TUBE	1	T 3.2	
8	HRA1502800A4	브래킷판	CLAMP,TUBE	1	T 3.2	
8	HRA1502800A4	브래킷판	CLAMP,TUBE	2	T 3.2	
8	HRA1502800A4	브래킷판	CLAMP,TUBE	1	T 3.2	
8	HRA1502800B4	브래킷판	CLAMP,TUBE	2	T 3.2	
9	HRA1500900C3	퇴유파이프조합	PIPE ASSY, FUEL RETURN	1		
9	HRA1500900C3	퇴유파이프조합	PIPE ASSY, FUEL RETURN	1		
9	HRA1500900C3	퇴유파이프조합	PIPE ASSY, FUEL RETURN	1		
9	HRA1500900D3	퇴유파이프조합	PIPE ASSY, FUEL	1		
10	HRA1502600B4	브래킷(연료파이프)	BRACKET,PIPE	1		
10	HRA1502600B4	브래킷(연료파이프)	BRACKET,PIPE	1		
10	HRA1502600B4	브래킷(연료파이프)	BRACKET,PIPE	1		
10	HRA1502600B4	브래킷(연료파이프)	BRACKET,PIPE	1		
11	26367-060002	플랜지너트	Nut, Hexa (Φ6)	2	M6XP1.0	
11	26367-060002	플랜지너트	Nut, Hexa (Φ6)	2	M6XP1.0	
11	26367-060002	플랜지너트	Nut, Hexa (Φ6)	2	M6XP1.0	
11	26367-060002	플랜지너트	Nut, Hexa (Φ6)	2	M6XP1.0	

A14_003

A2300T3-ETC_5
(AB00333)

FUEL FILTER BRACKET

Year/Month

2022-12-19

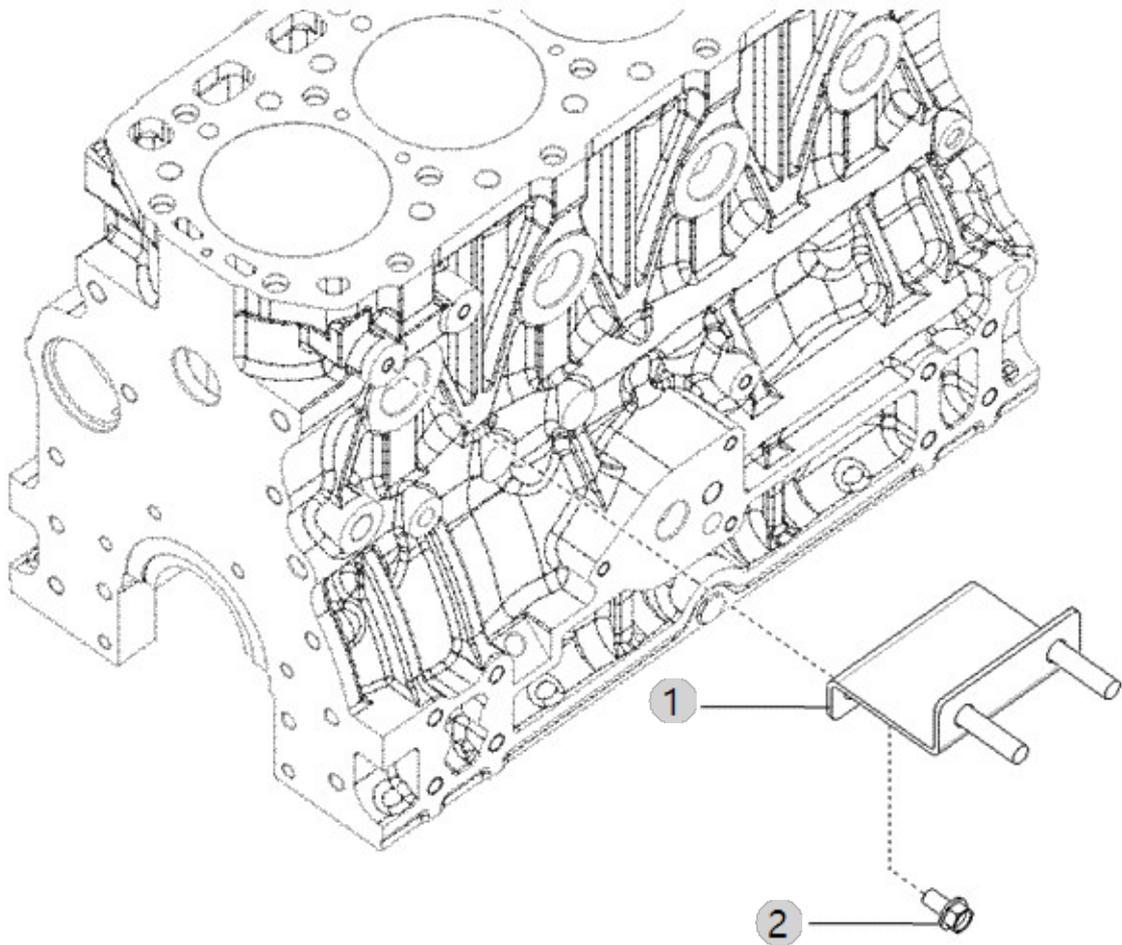

A16_003

A2300T3-ETC_5
(AB00333)

FUEL FILTER ASS'Y OPTION

Year/Month

2022-12-19

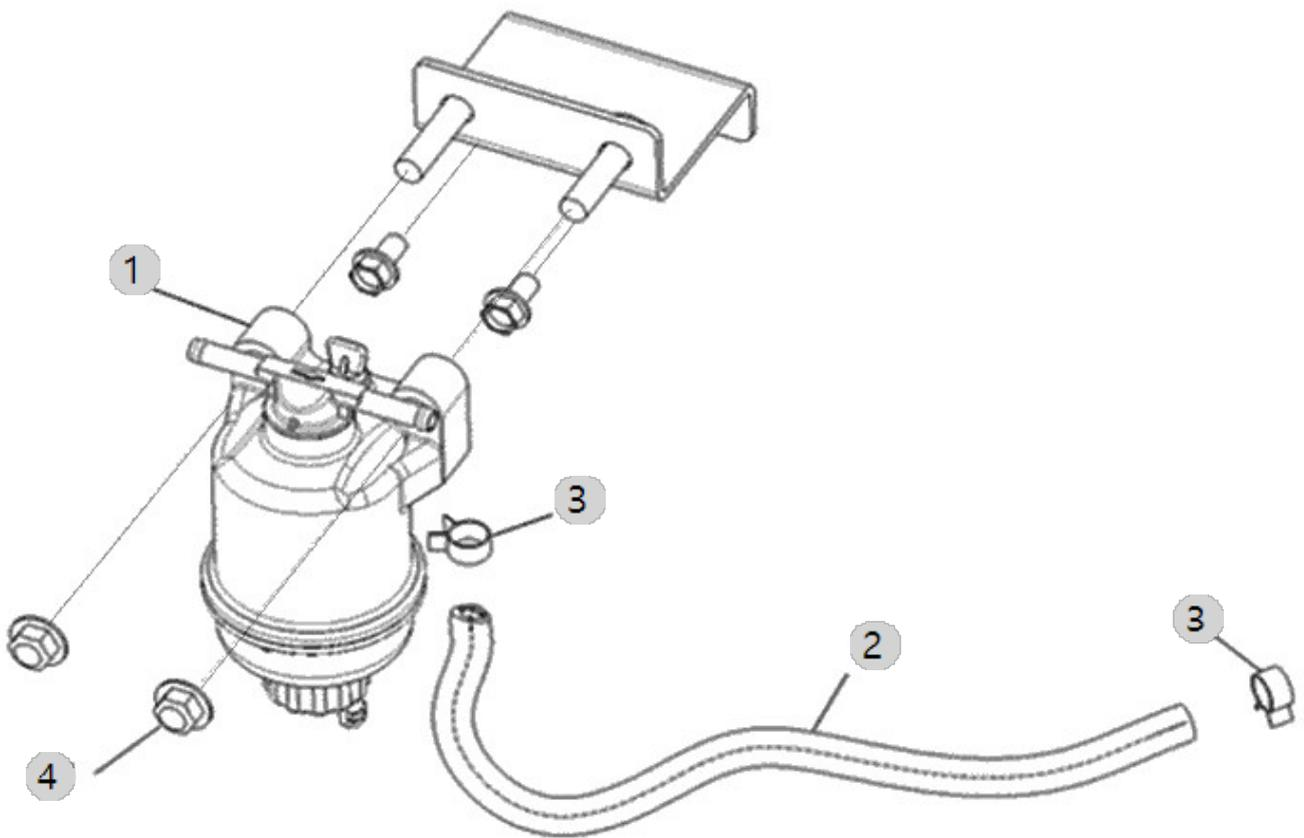

A17_008

A2300T3-ETC_5
(AB00333)

INTAKE MANIFOLD ASS'Y OPTION

Year/Month

2022-12-19

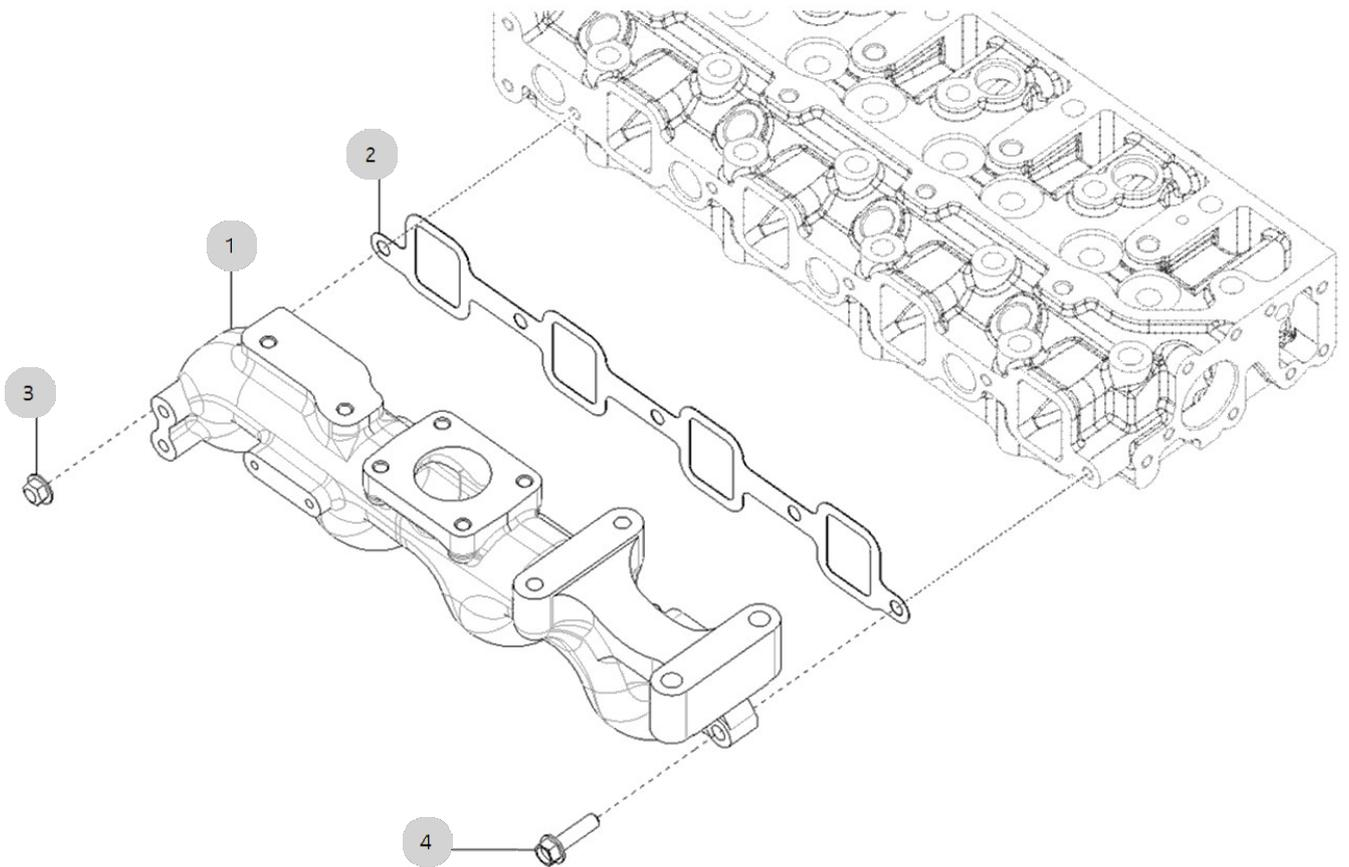

A18_011

A2300T3-ETC_5
(AB00333)

FLYWHEEL

Year/Month

2022-12-19

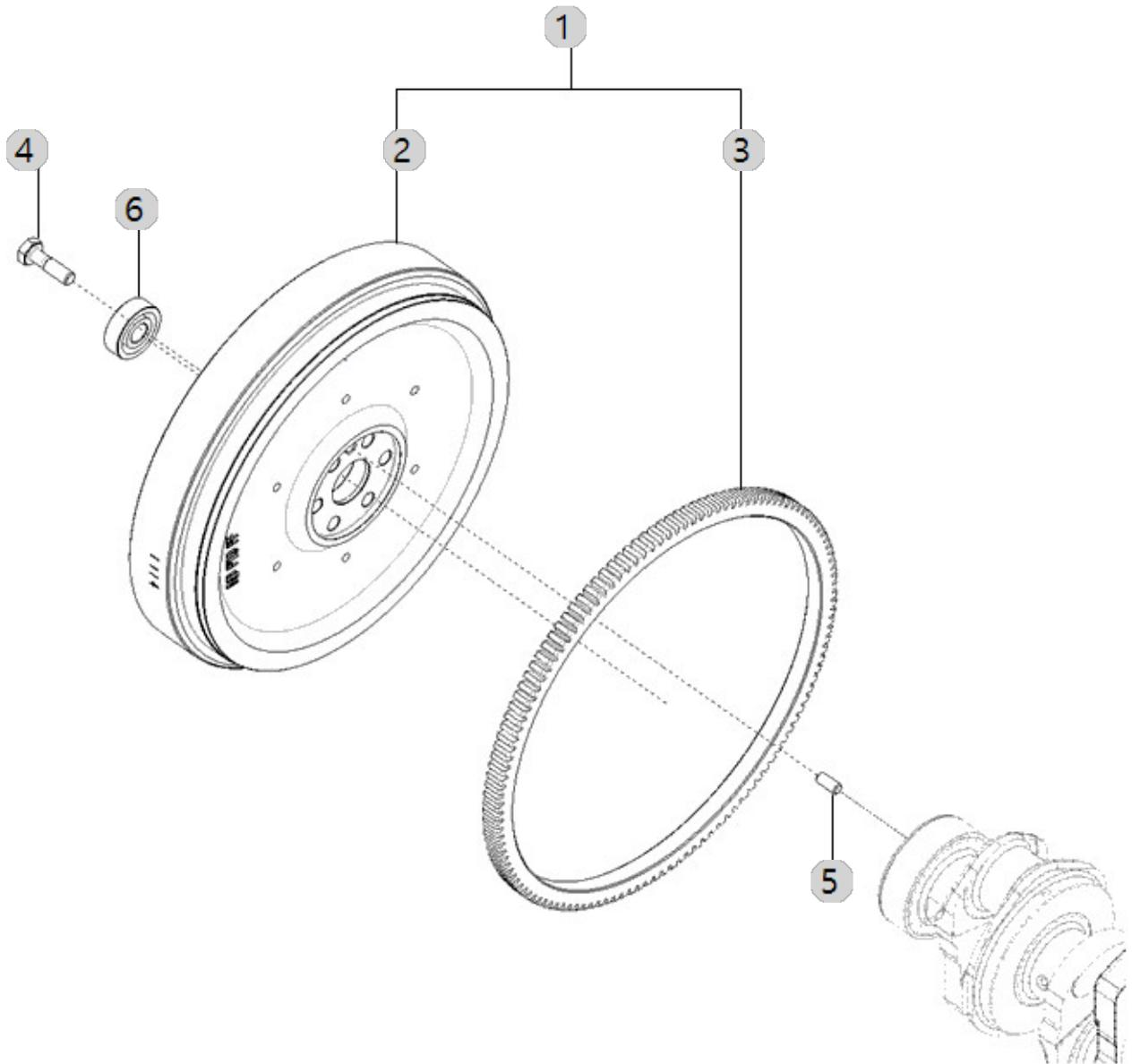

A19_009

A2300T3-ETC_5
(AB00333)

FLYWHEEL HOUSING

Year/Month

2022-12-19

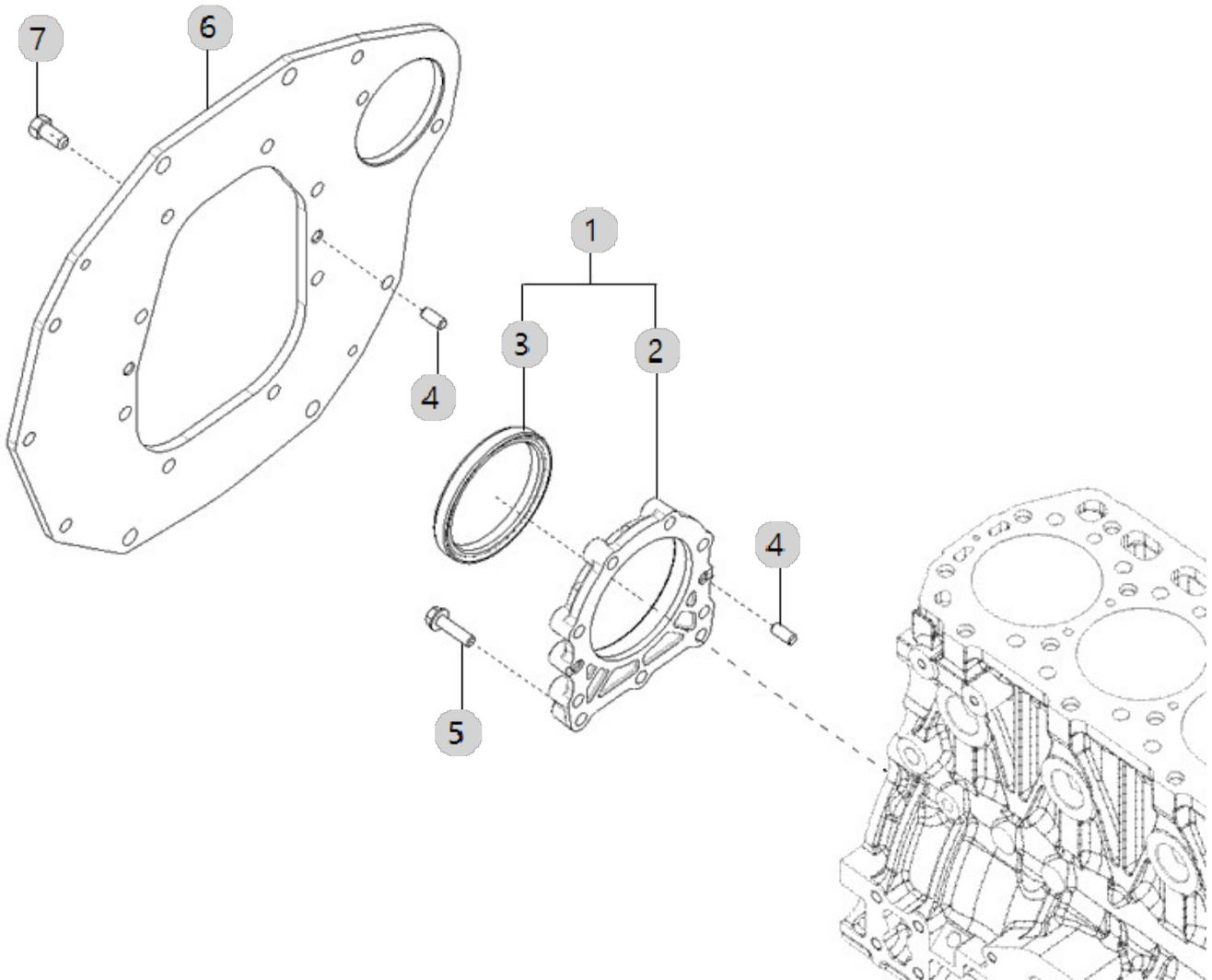

A20_011

A2300T3-ETC_5
(AB00333)

HEAD, CYLINDER

Year/Month

2022-12-19

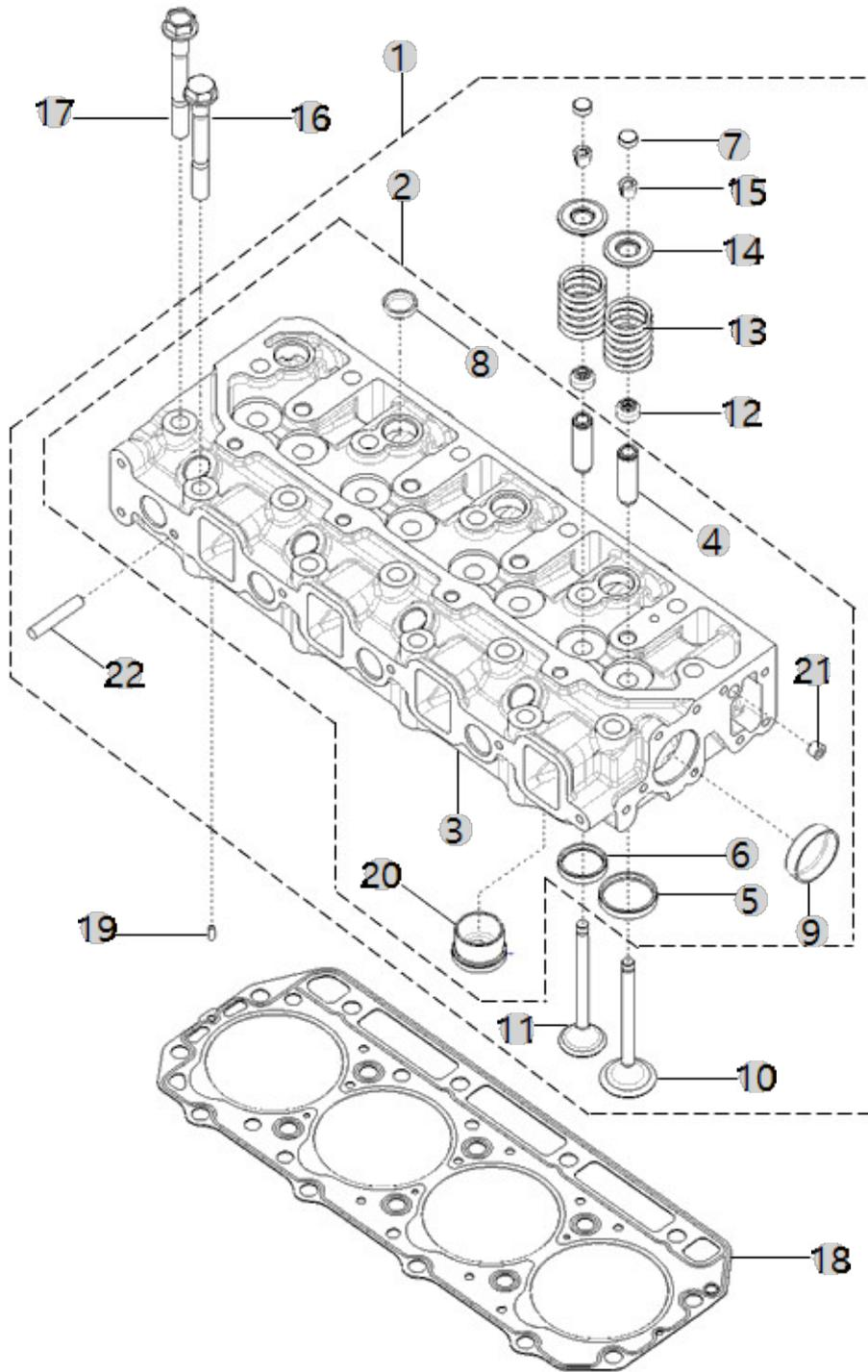

A20_011 A2300T3-ETC_5 (AB00333)		HEAD, CYLINDER				Year/Month
						2022-12-19
순번 (NO)	부품번호 (PART NO)	품명 (PART NAME)	품명 (PART NAME)	수량 (QTY)	규격 (SPEC)	비고 (REMARK)
1	EA00004718A	실린더헤드조합-A2300T15-KTR_4	CYLINDER HEAD ASSY	1		
2	EA00000635A	실린더헤드조합	HEAD, CYLINDER	1	NONE	
3	HRU220100MC0	실린더헤드(소재)	HEAD, CYLINDER	1		
3	HRU220100MB0	실린더헤드(소재)	HEAD, CYLINDER	1		
4	HRA0400103C4	배기밸브가이드	GUIDEVALVE STEM	8	D13/D8	
4	HRA0400103C4	배기밸브가이드	GUIDEVALVE STEM	4	D13/D8	
4	HRA0400103B4	배기밸브가이드	GUIDE,VALVESTEM	4		
5	HRA0400104B4	흡기밸브시트	SEAT,ENGINEINTAKEVALVE	4		
6	HRA0400105B4	배기밸브시트	SEAT,ENGINE EXHAUST VALVE	4		
7	HK03680000B4	344,ALL, 밸브캡	CAP,VALVE	8		
8	27241-220000	캡형플러그 22	PLUG,EXPANSION	8		
9	27241-400000	캡형플러그 40 (335,ALL,PLUG40)	PLUG (D40)	2		
10	HRA0400200A4	337,ALL, 흡기밸브	VALVE,INTAKE	4		
11	HRA0400300A4	338,ALL, 배기밸브	VALVE,EXHAUST	4		
12	HA03070000A4	340,ALL, 밸브축시일	SEAL,VALVESTEM	8		
13	HRA0400700A4	341,ALL, 밸브스프링	SPRING,VALVE	8		
14	HRA0400800A4	342,ALL, 밸브스프링리테이너	RETAINER,VALVESPING	8		
15	HRA0400900A4	343,ALL, 밸브스프링코터	COTTER,VALVE	16		
16	HRA0100700A4	347,ALL, 볼트(실린더헤드)	SCREW,HEXFLANGEHEADCAP	4	M11X1.5X92	
17	HRA0100500A4	실린더헤드 볼트	SCREW,HEXFLANGEHEADCAP	14	M11X1.5	
18	HRU0100400A2	헤드가스켓-A2300	GASKET,CYLINDER HEAD (A2300)	1		
18	HRU0100400B2	헤드가스켓	GASKET,CYLINDER HEAD	1	T1.28	
19	22312-040100	평행핀	PIN, DOWEL (4-10)	2	D4X10	
20	EA00000083A	예연소실	PRE-CHAMBER	4		
21	23871-010000	테이퍼플러그	PLUG	1	PT1/8	
22	26216-080352	심음볼트(1.5D)	BOLT, STUD 8 X 35	1	M8X1.25X35	

A21_004

A2300T3-ETC_5
(AB00333)

HEAD COVER

Year/Month

2022-12-19

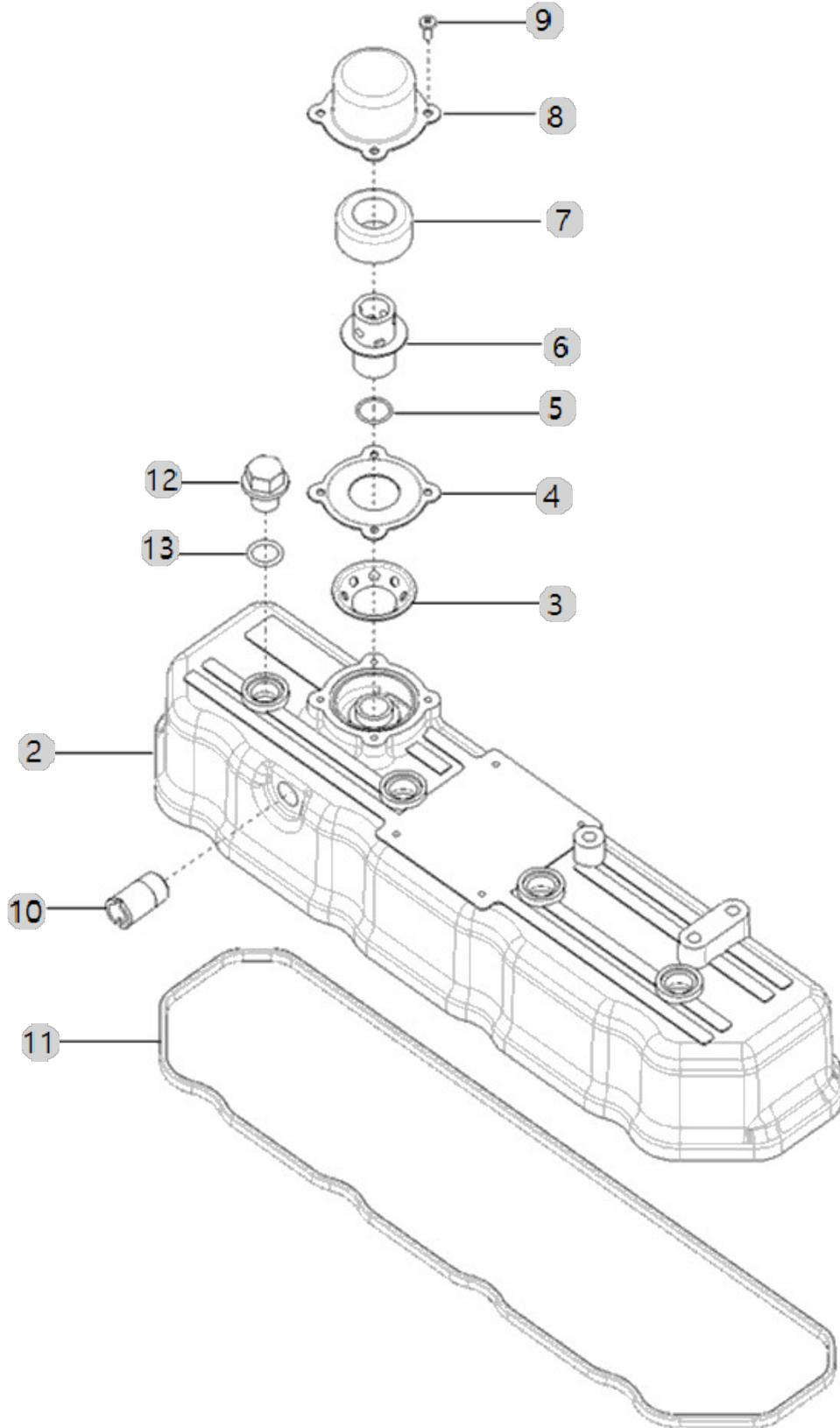

A23_008

A2300T3-ETC_5
(AB00333)

TURBOCHARGER SUPPORT ASS'Y OPTION

Year/Month

2022-12-19

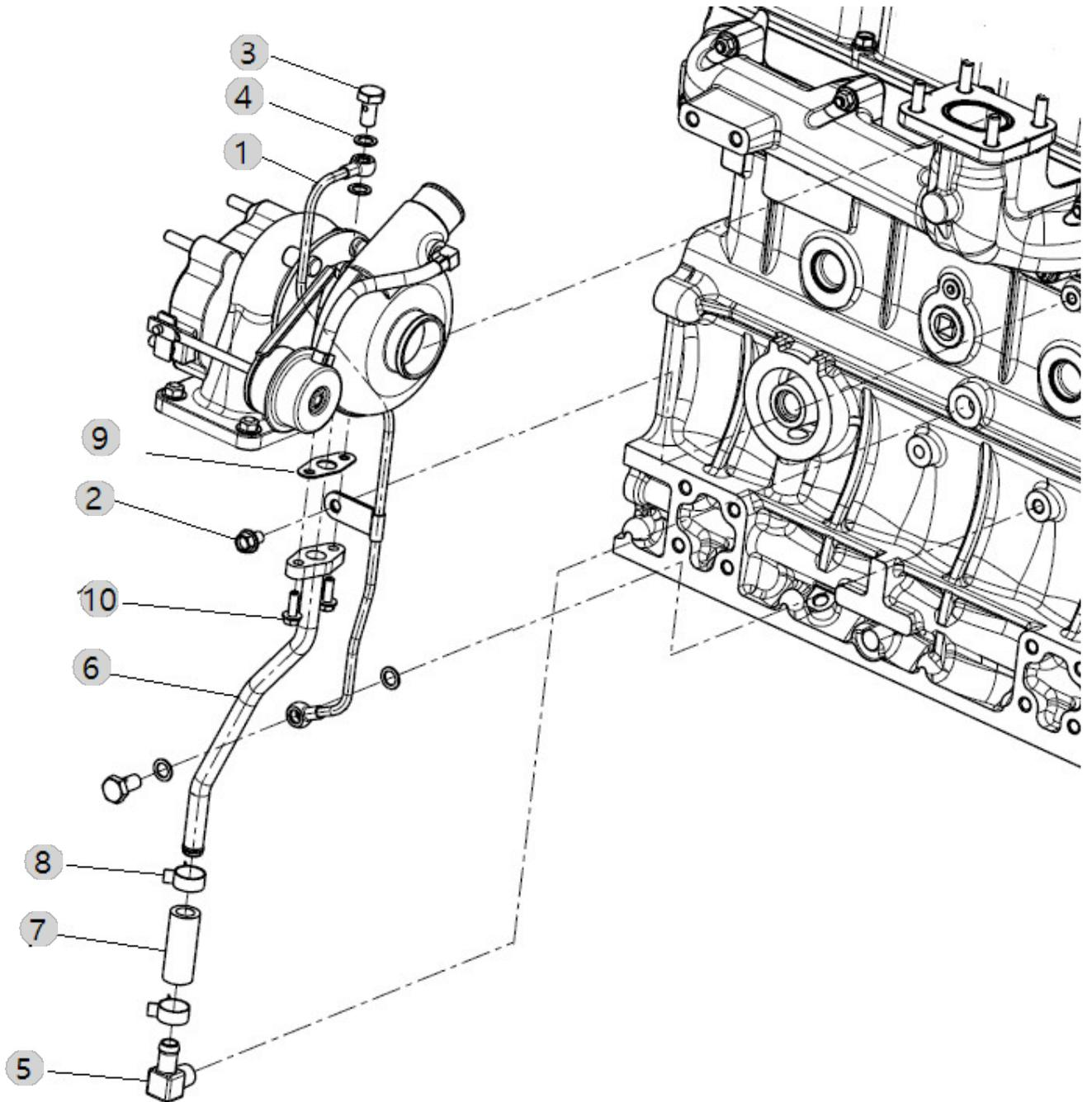

A24_003

A2300T3-ETC_5
(AB00333)

TURBOCHARGER

Year/Month

2022-12-19

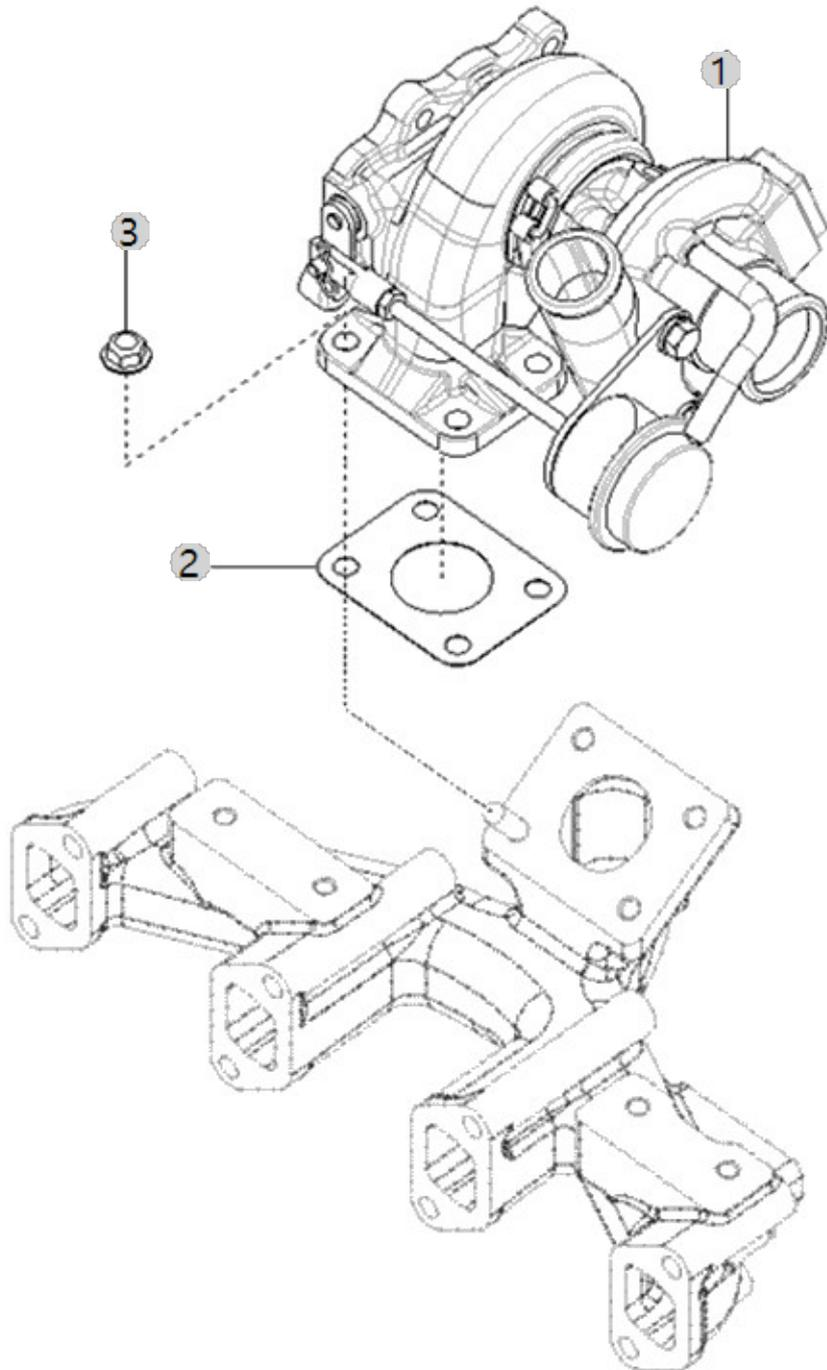

A25_003

A2300T3-ETC_5
(AB00333)

OIL JET ASS'Y OPTION

Year/Month

2022-12-19

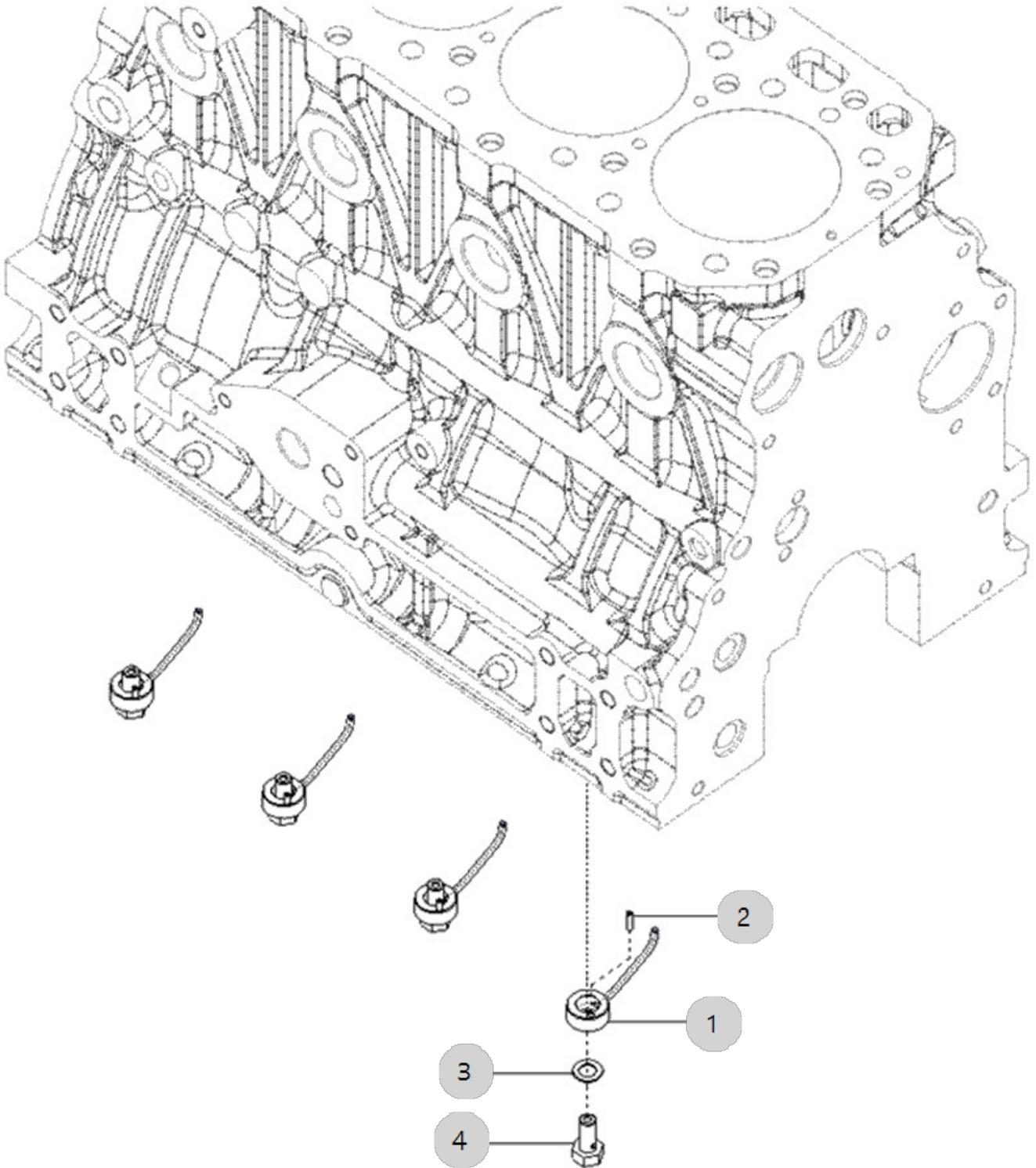

A26_005

A2300T3-ETC_5
(AB00333)

COOLER, ENGINE OIL

Year/Month

2022-12-19

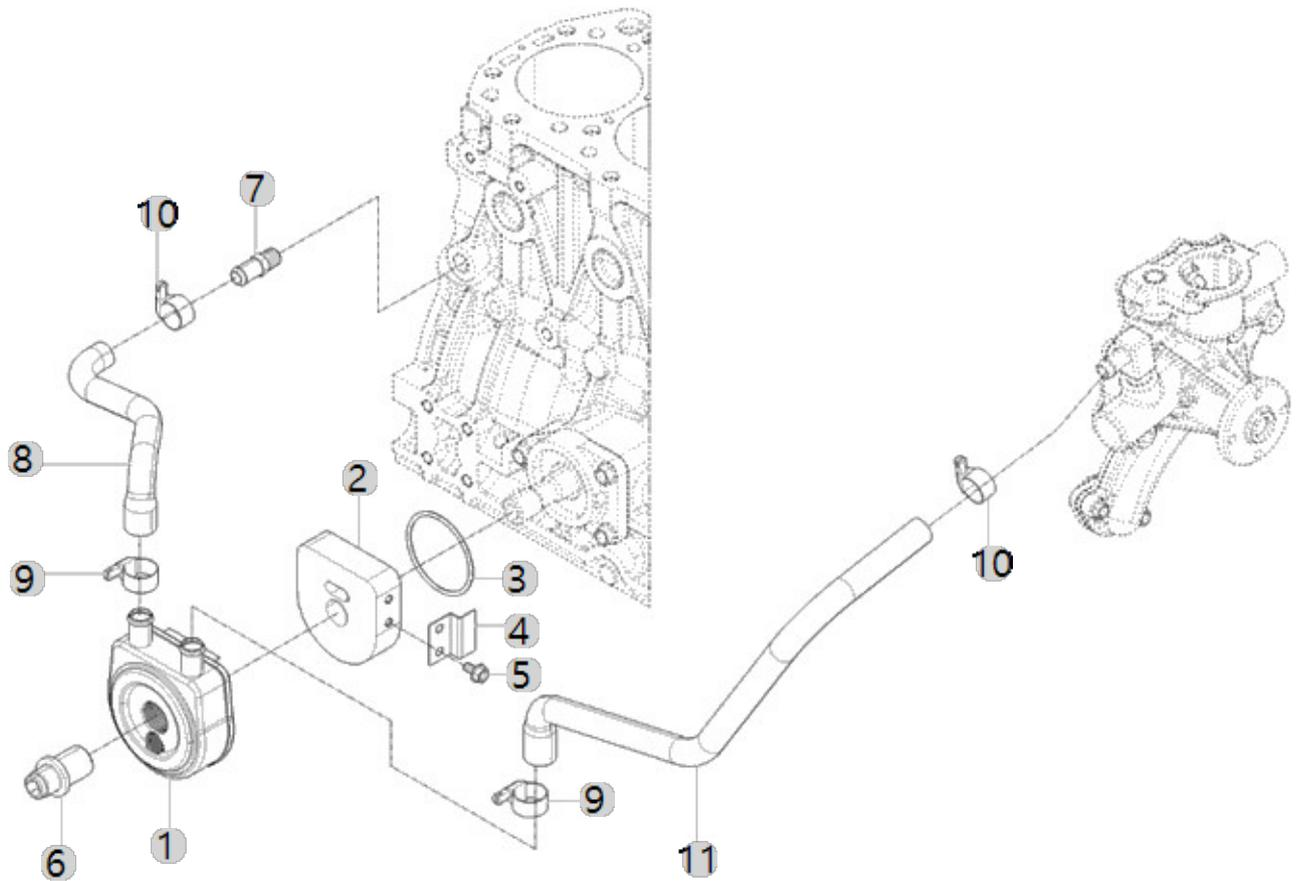

A27_010

A2300T3-ETC_5
(AB00333)

OIL PAN ASS'Y OPTION

Year/Month

2022-12-19

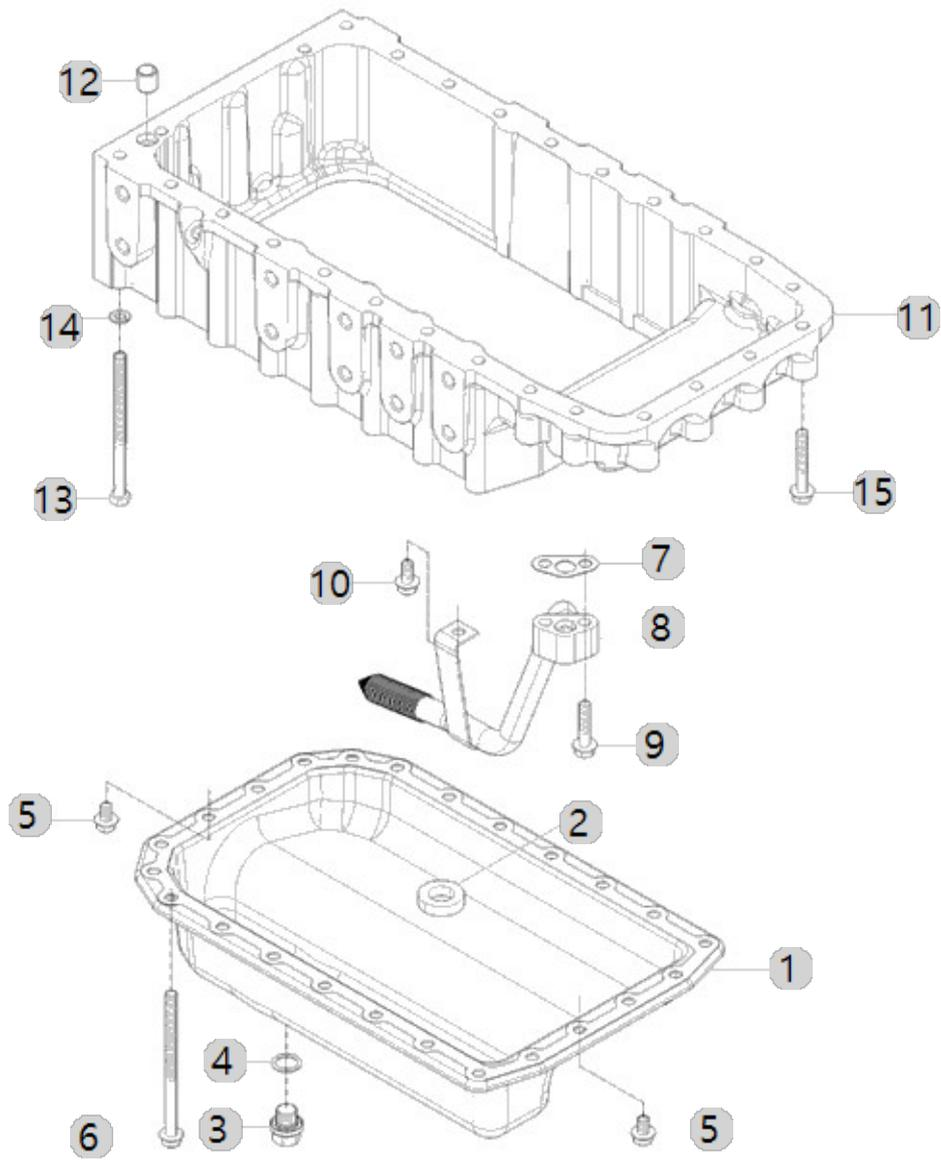

A28_001

A2300T3-ETC_5
(AB00333)

PUMP, LUBRICATING OIL

Year/Month

2022-12-19

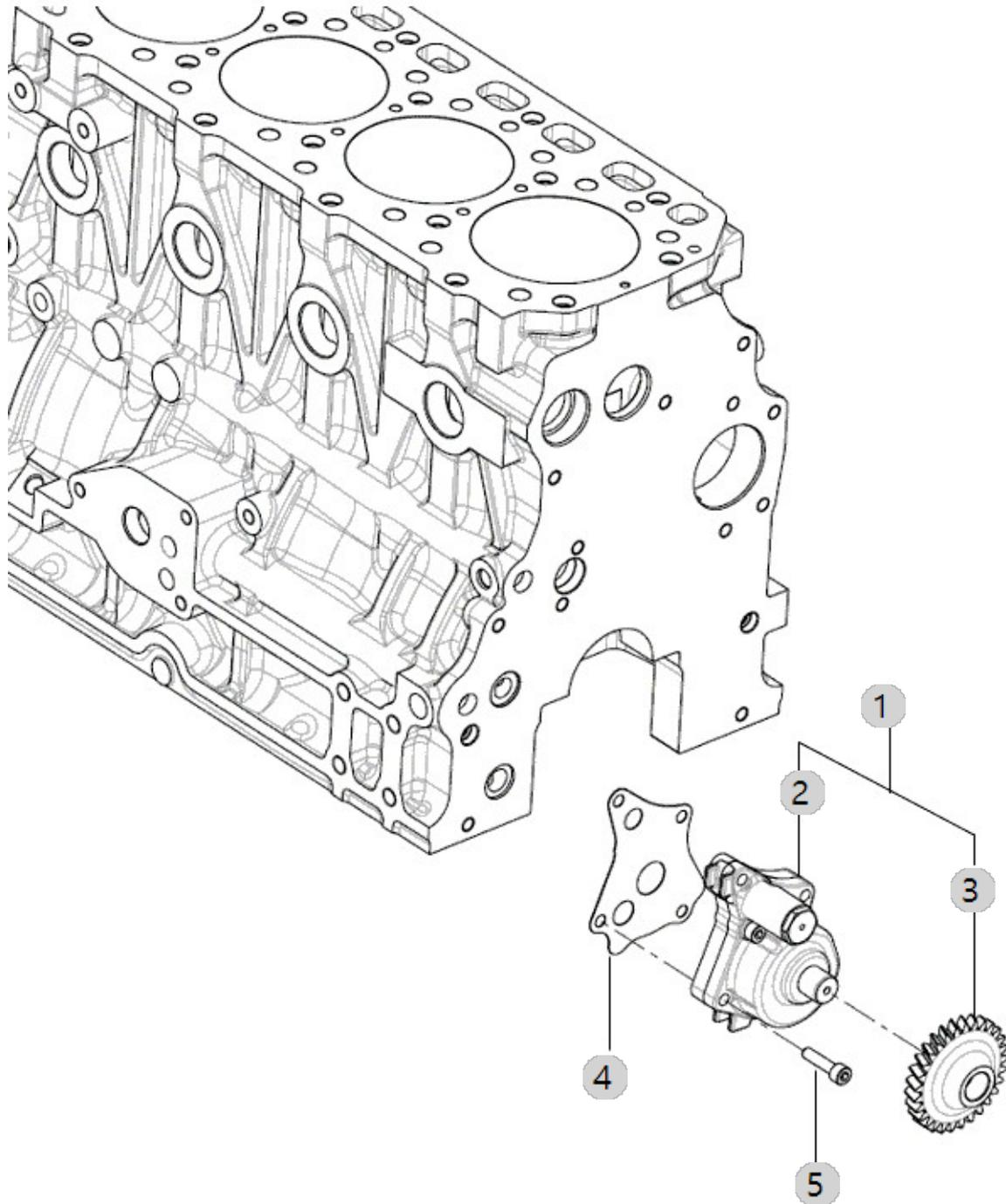

A29_005

A2300T3-ETC_5
(AB00333)

FILTER, LUBRICATING OIL

Year/Month

2022-12-19

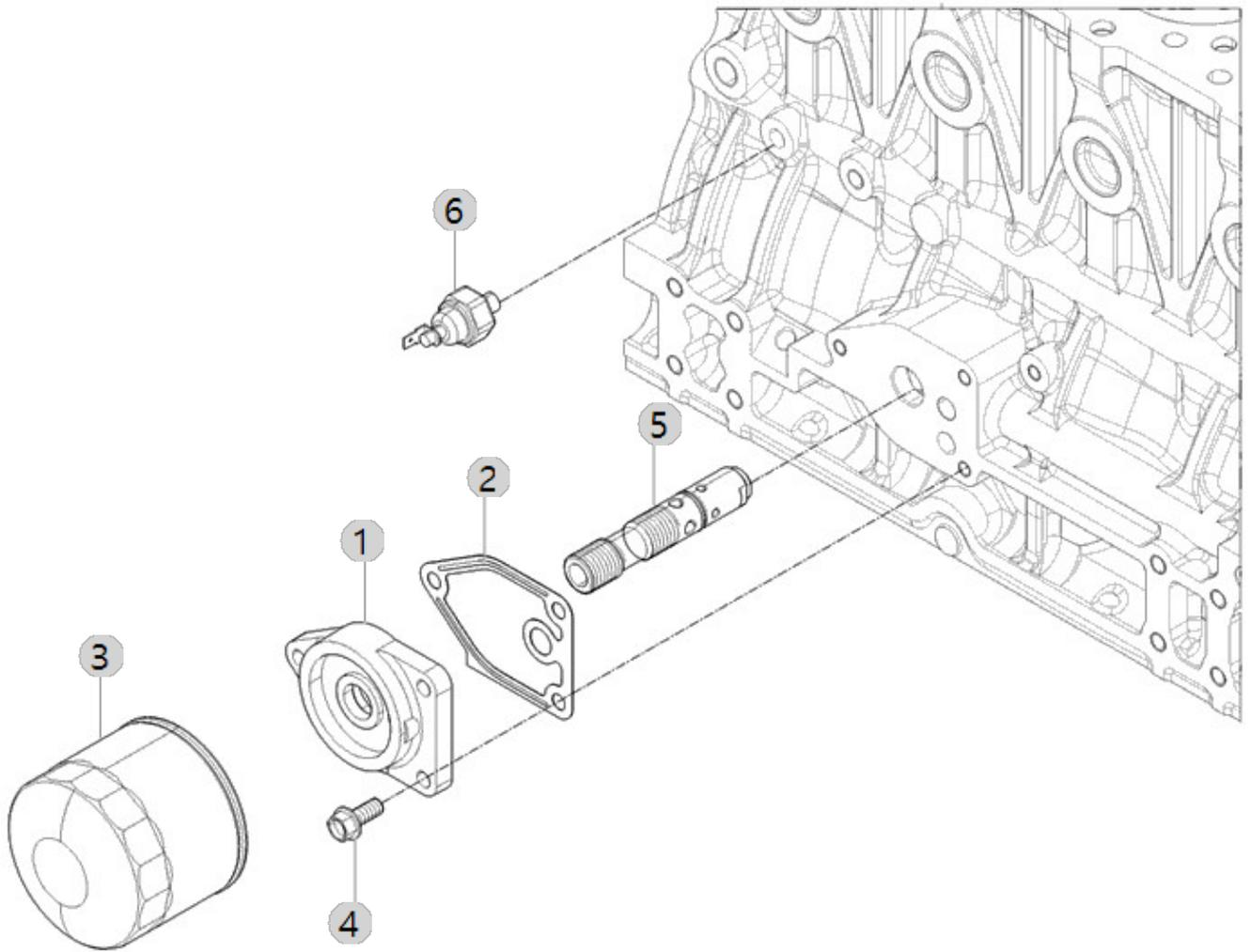

A30_003

A2300T3-ETC_5
(AB00333)

FRONT GEAR ACCESSORY DRIVE

Year/Month

2022-12-19

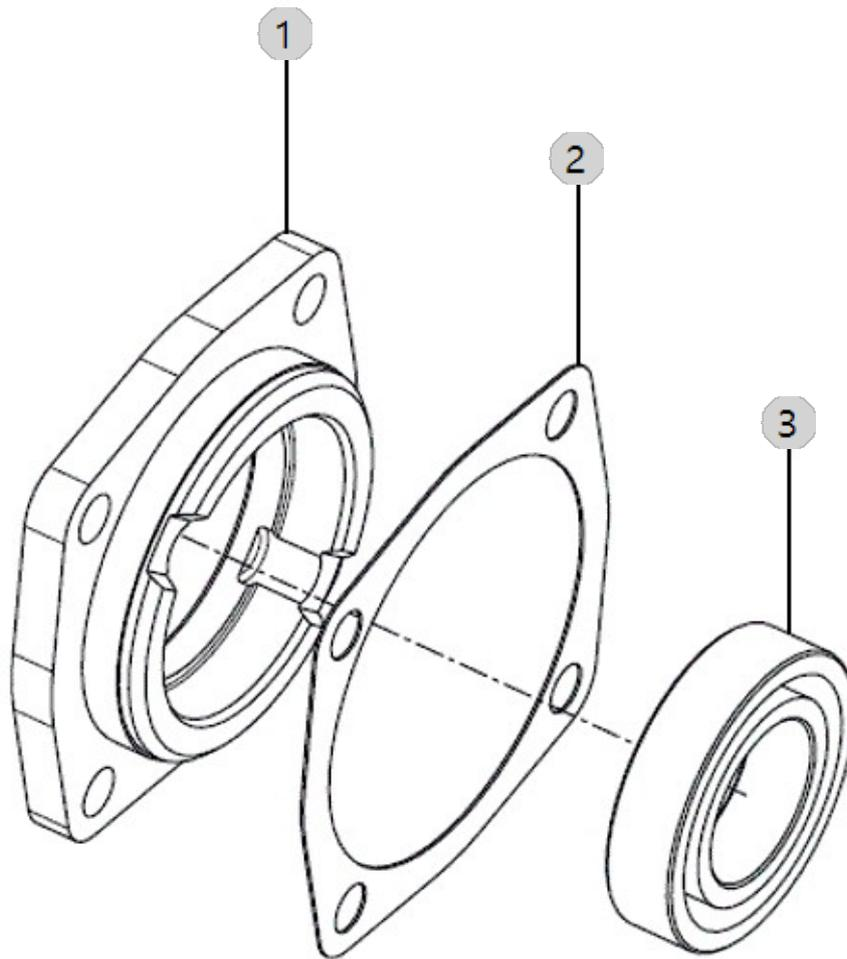

A31_007

A2300T3-ETC_5
(AB00333)

PISTON

Year/Month

2022-12-19

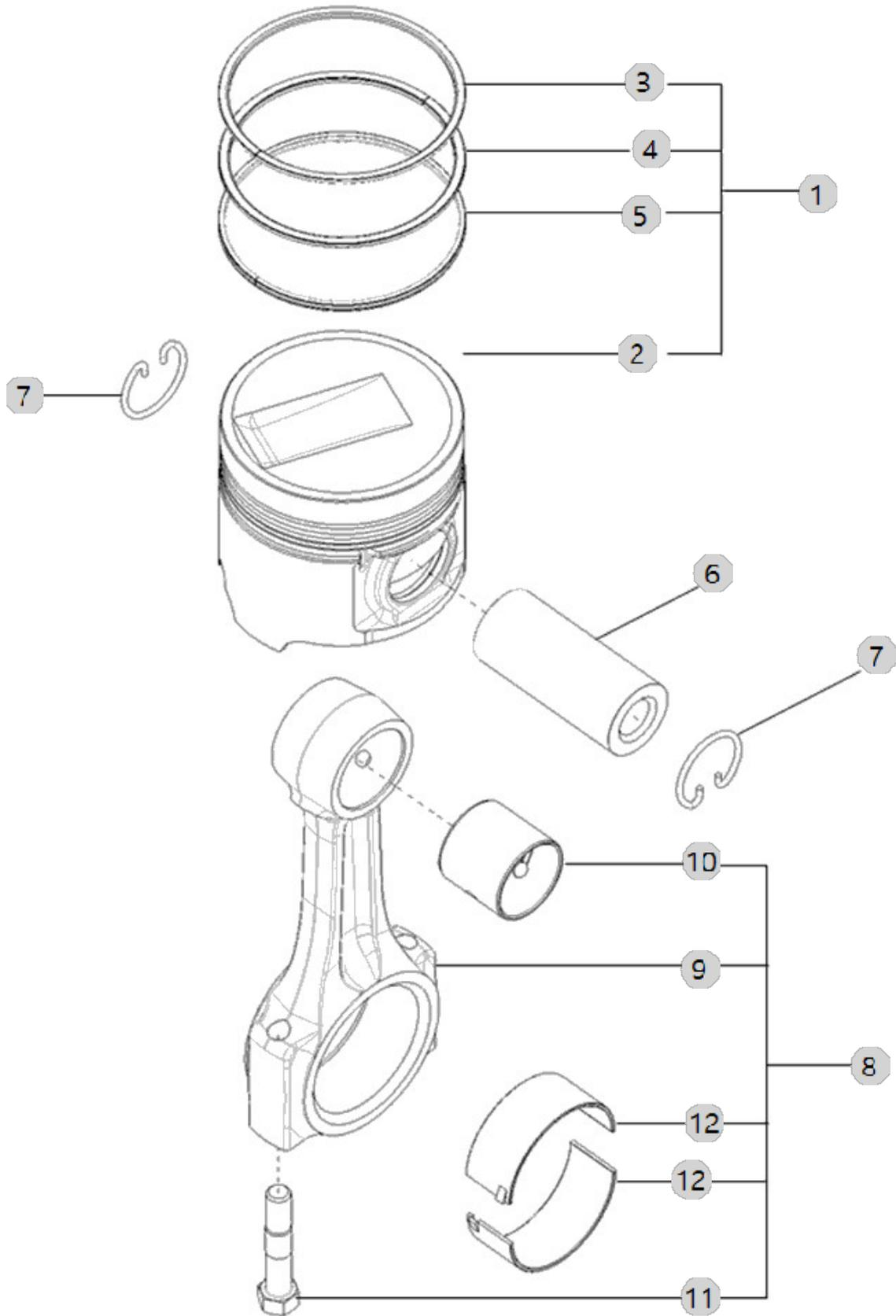

A32_003

A2300T3-ETC_5
(AB00333)

LEVER, LOCKER

Year/Month

2022-12-19

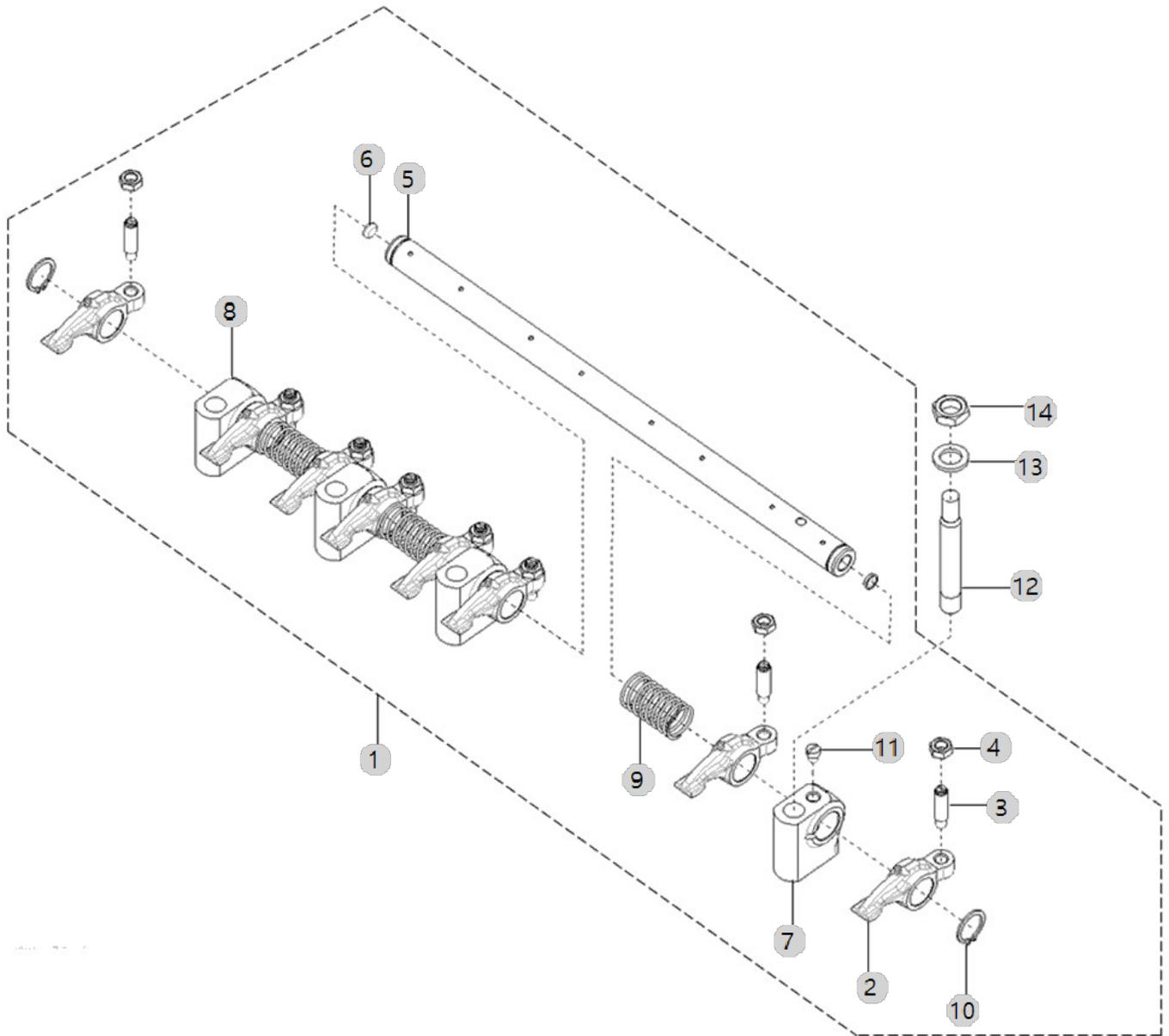

A32_003		LEVER, LOCKER				Year/Month
A2300T3-ETC_5 (AB00333)						2022-12-19
순번 (NO)	부품번호 (PART NO)	품 명 (PART NAME)	품 명 (PART NAME)	수량 (QTY)	규격 (SPEC)	비고 (REMARK)
1	HRA0401100C2	로커암축조합	LEVER,ROCKER	1		
1	HRA0401100B2	로커암축조합	LEVER,ROCKER	1		
1	HRA0401100D2	로커암축조합	LEVER,ROCKER	1		
2	HRA0401600C4	로커암	LEVER,ROCKER	8		
2	HRA0401600A4	416,ALL,로커암	LEVER,ROCKER	8		
2	HRA0401600B4	로커암	LEVER,ROCKER	8		
3	AF02110000E4	밸브조정나사	SCREW,RKRLEVERADJUSTING	8		
4	HH05280000A4	418,ALL,너트	NUT,VALVEADJUSTING	8		
5	HRA0401501B9	로커암축		1		
5	HRA0401501A9	로커암축		1		
6	27241-100000	캡형플러그 10	PLUG 10	2		
7	HRA0401200A4	412,ALL,써포트(A)	SUPPORT,ROCKERLEVER	1		
8	HRA0401300A4	써포트(B)	SUPPORT,ROCKERLEVER	3		
9	HRA0401400A4	414,ALL,스프링(로커암)	SPRING,COMPRESSION	3		
10	22242-000190	축용스냅링19	SNAP RING, SHAFT (Φ 19)	2	D19	
11	26921-080102	419,ALL,STOPSCREW	SCREW,SLOTTEDSET	1		
12	HRA0401800A4	421,ALL,심음볼트	STUD	4		
13	22117-120000	422,ALL,와셔12	WASHER, PLAIN (Φ 12)	4	M12	
14	HA03180000B4	423,ALL,너트	NUT,REGULARHEXAGON	4		

A33_011

A2300T3-ETC_5
(AB00333)

EXHAUST MANIFOLD

Year/Month

2022-12-19

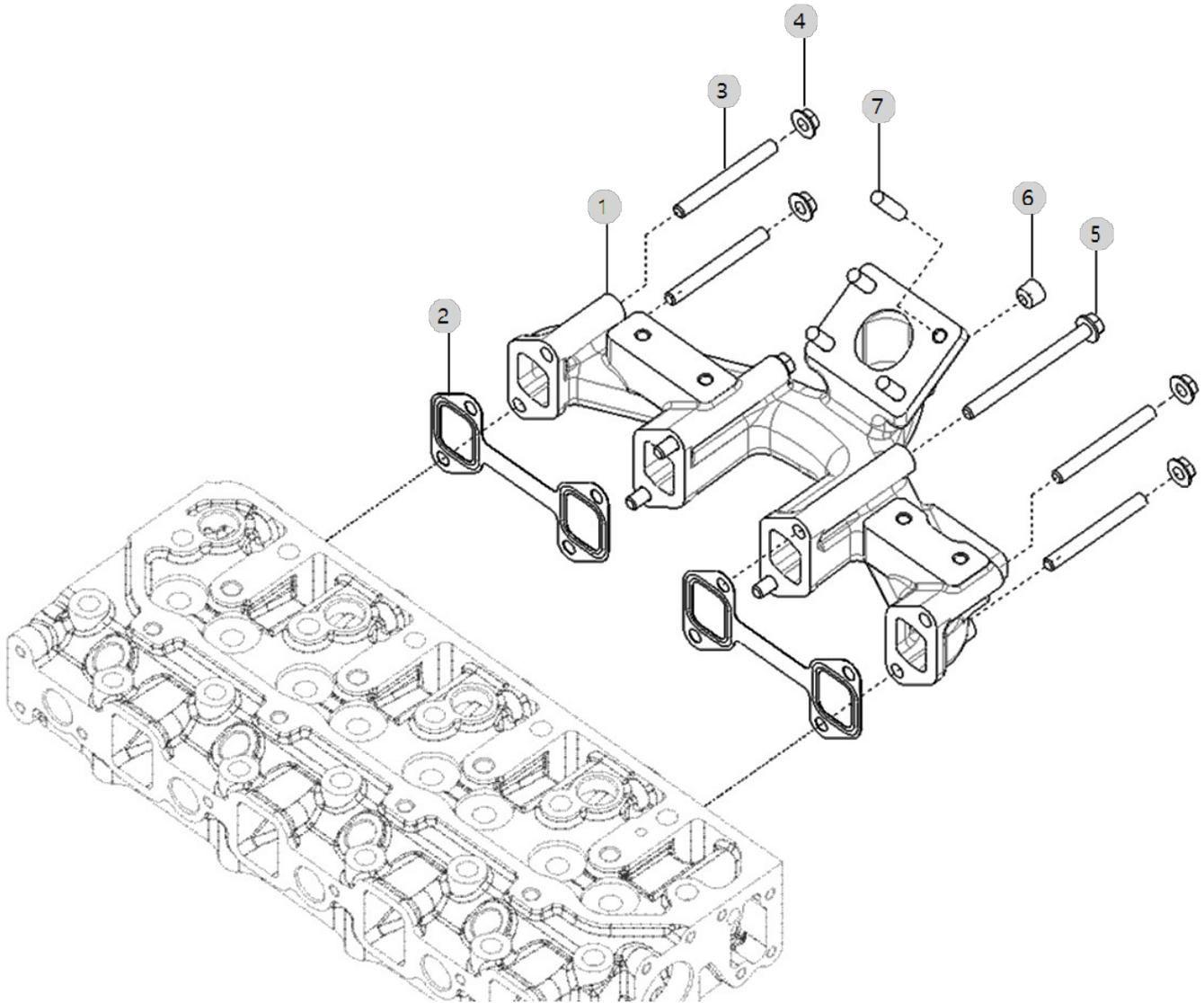

A35_002

A2300T3-ETC_5
(AB00333)

IDLE GEAR

Year/Month

2022-12-19

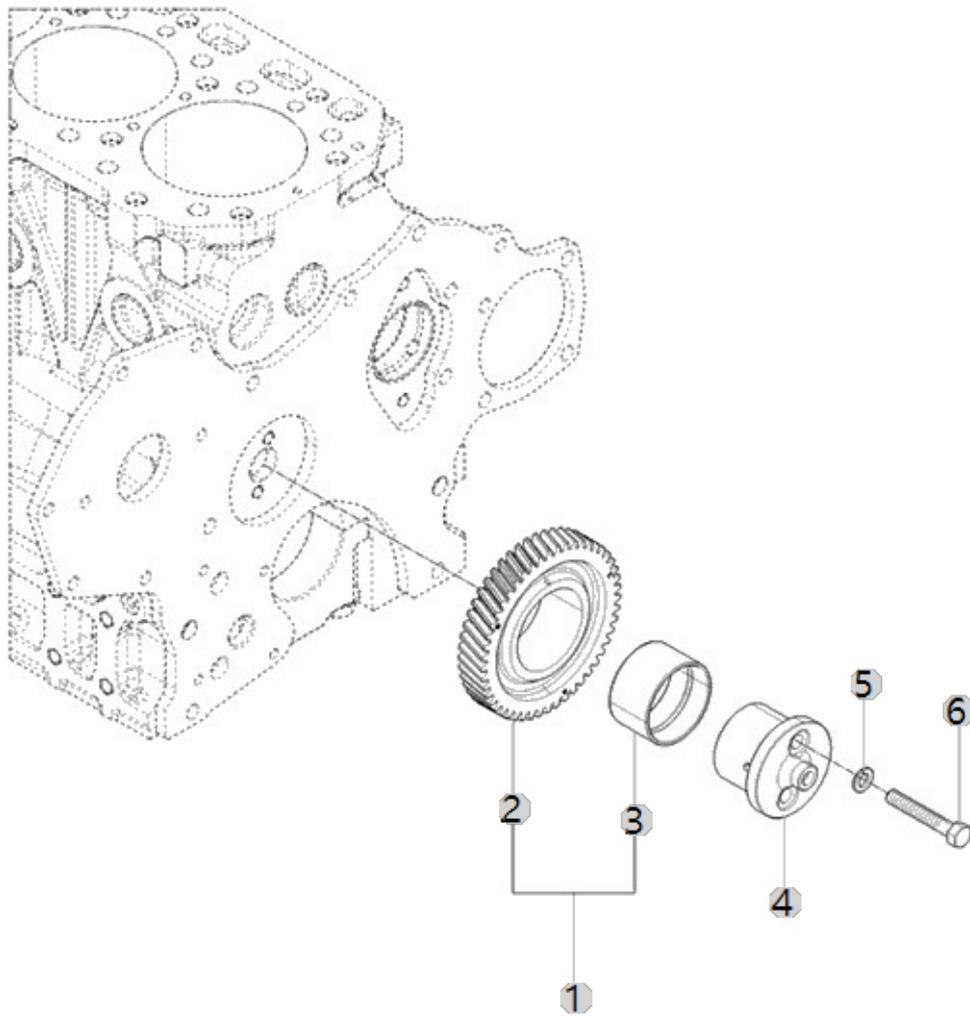

A36_004

A2300T3-ETC_5
(AB00333)

COVER, FRONT GEAR

Year/Month

2022-12-19

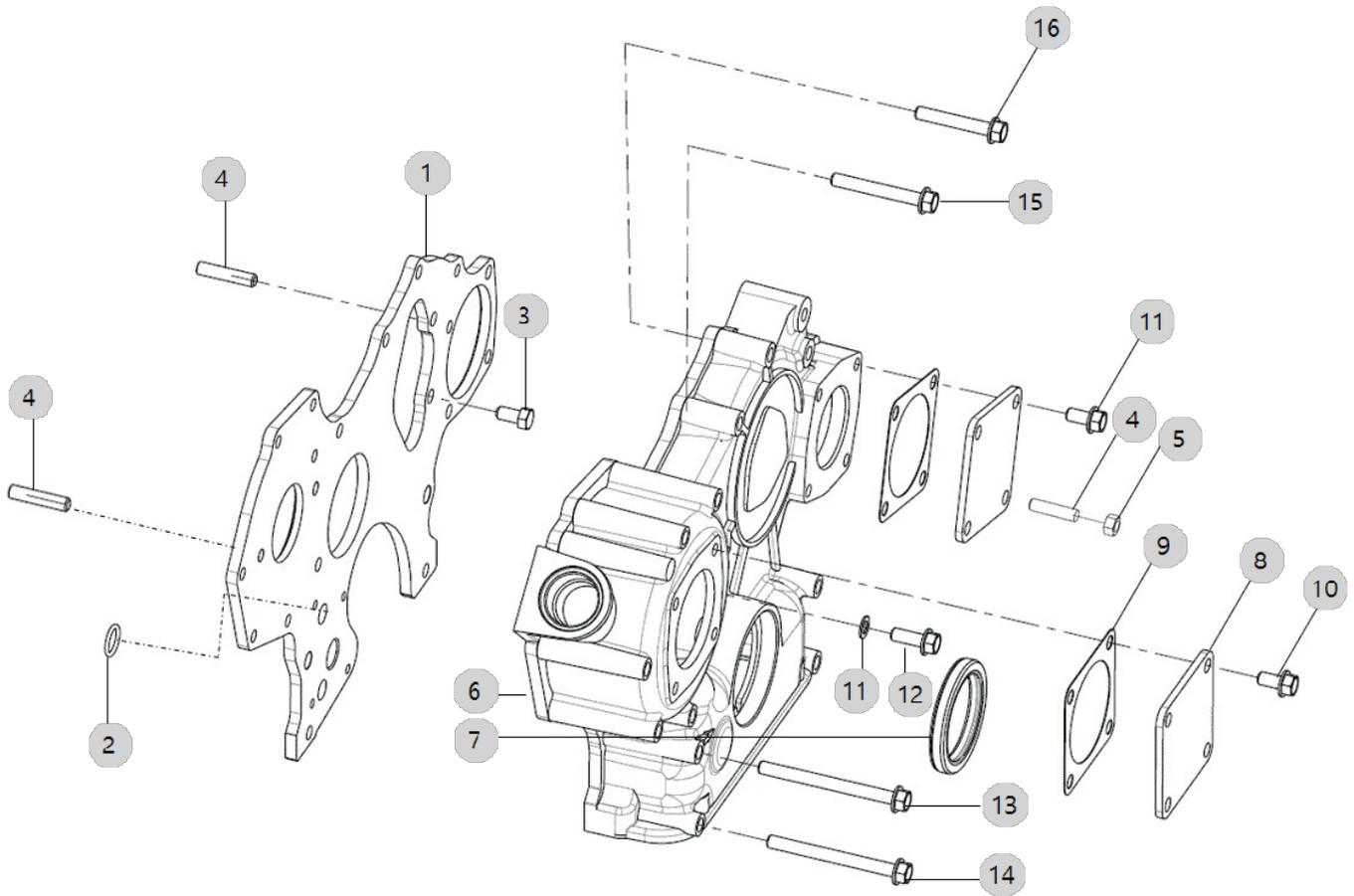

A37_001

A2300T3-ETC_5
(AB00333)

BALANCE ASS'Y

Year/Month

2022-12-19

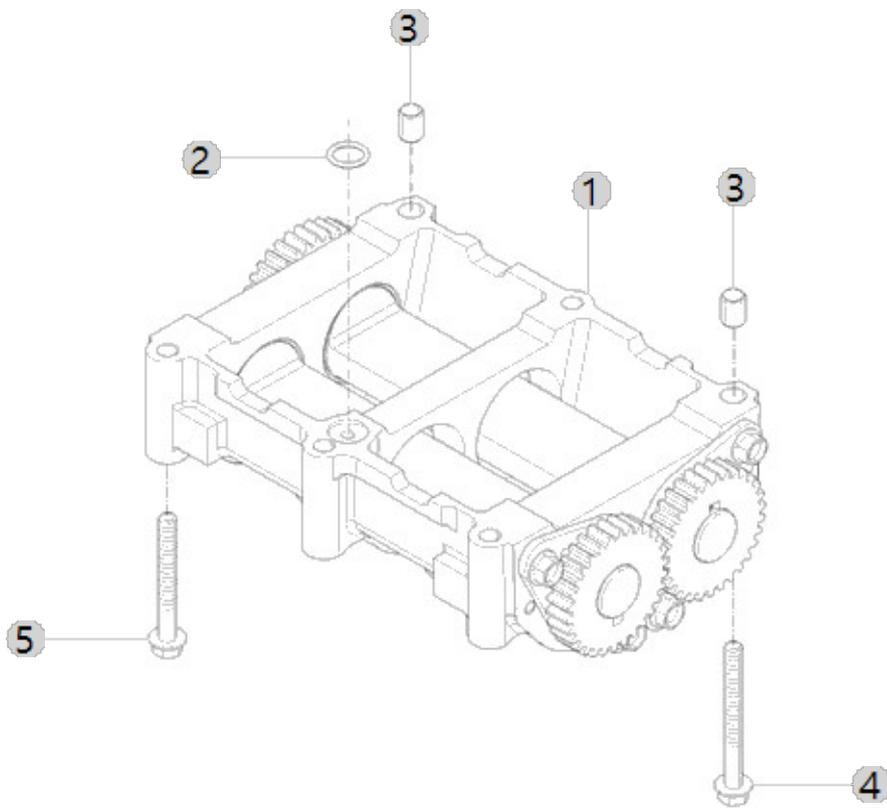

A38_007

A2300T3-ETC_5
(AB00333)

GAUGE, OIL LEVEL

Year/Month

2022-12-19

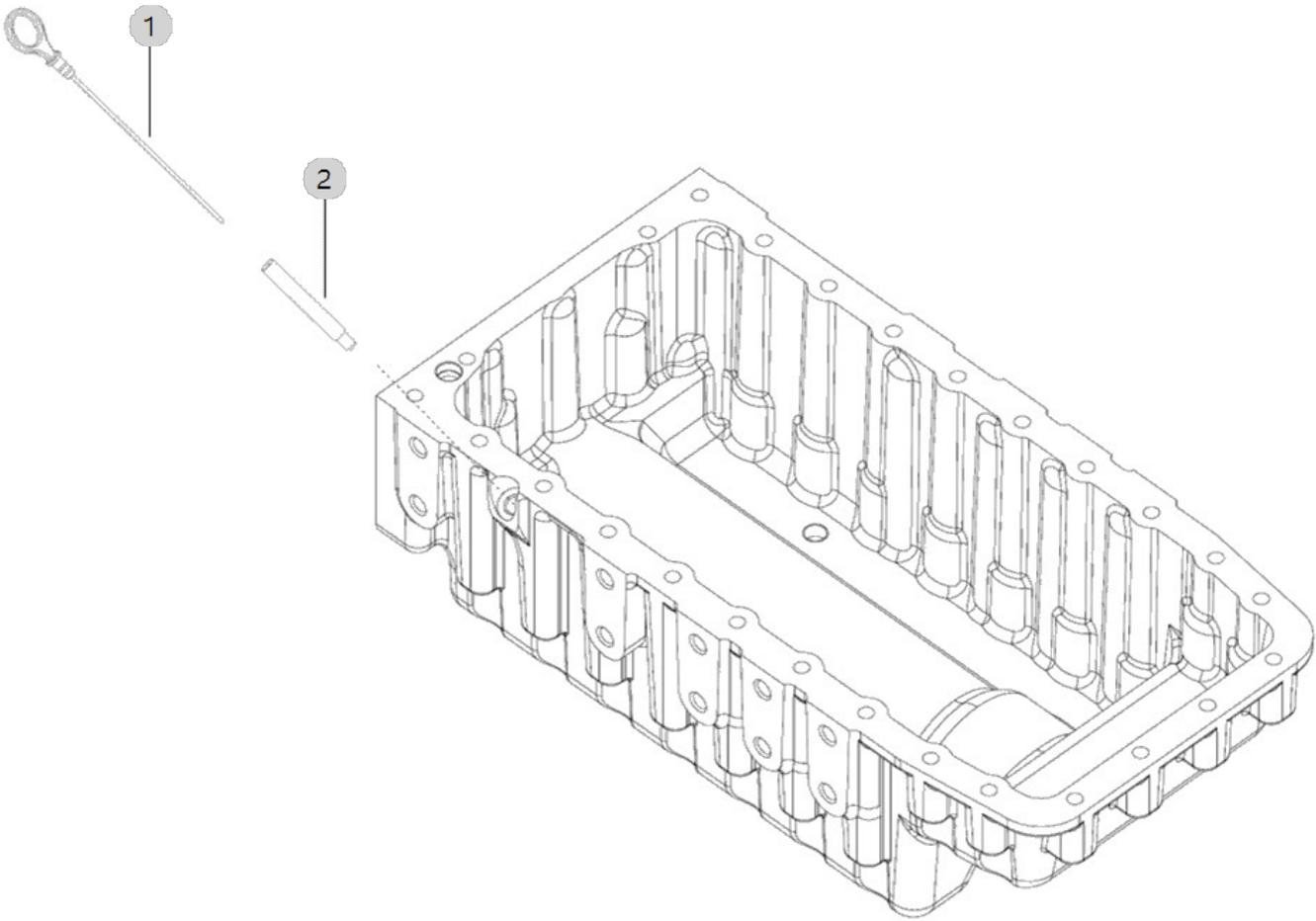

A39_001

A2300T3-ETC_5
(AB00333)

OIL FILLER CAP

Year/Month

2022-12-19

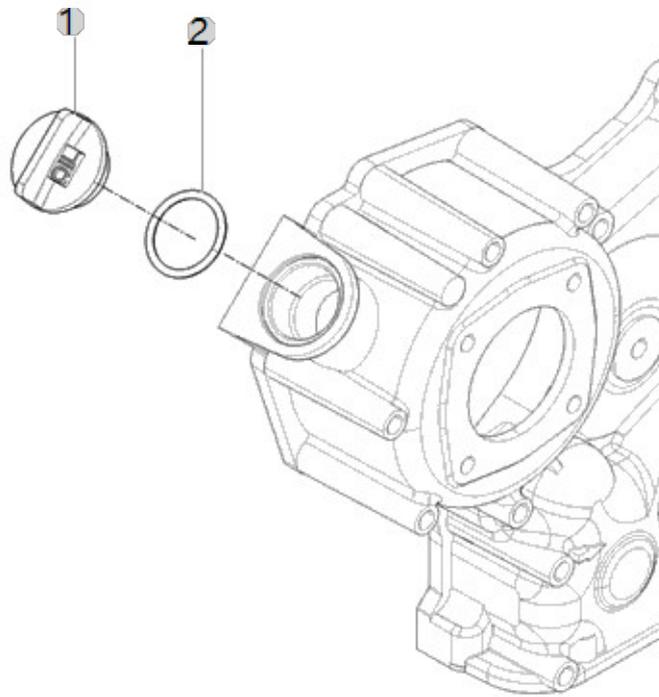

A40_003

A2300T3-ETC_5
(AB00333)

LIFT ASS'Y OPTION

Year/Month

2022-12-19

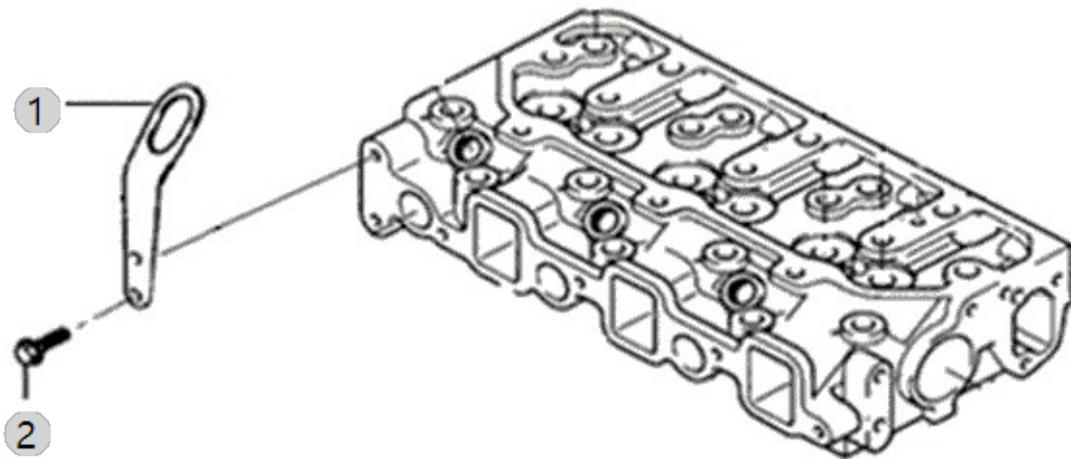

A41_001

A2300T3-ETC_5
(AB00333)

COMP,DRIVE PULLEY ASS'Y OPTION

Year/Month

2022-12-19

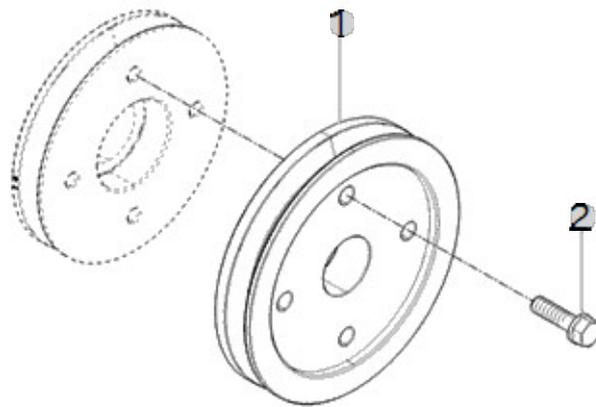

A42_003

A2300T3-ETC_5
(AB00333)

MOTER, STARTIONS

Year/Month

2022-12-19

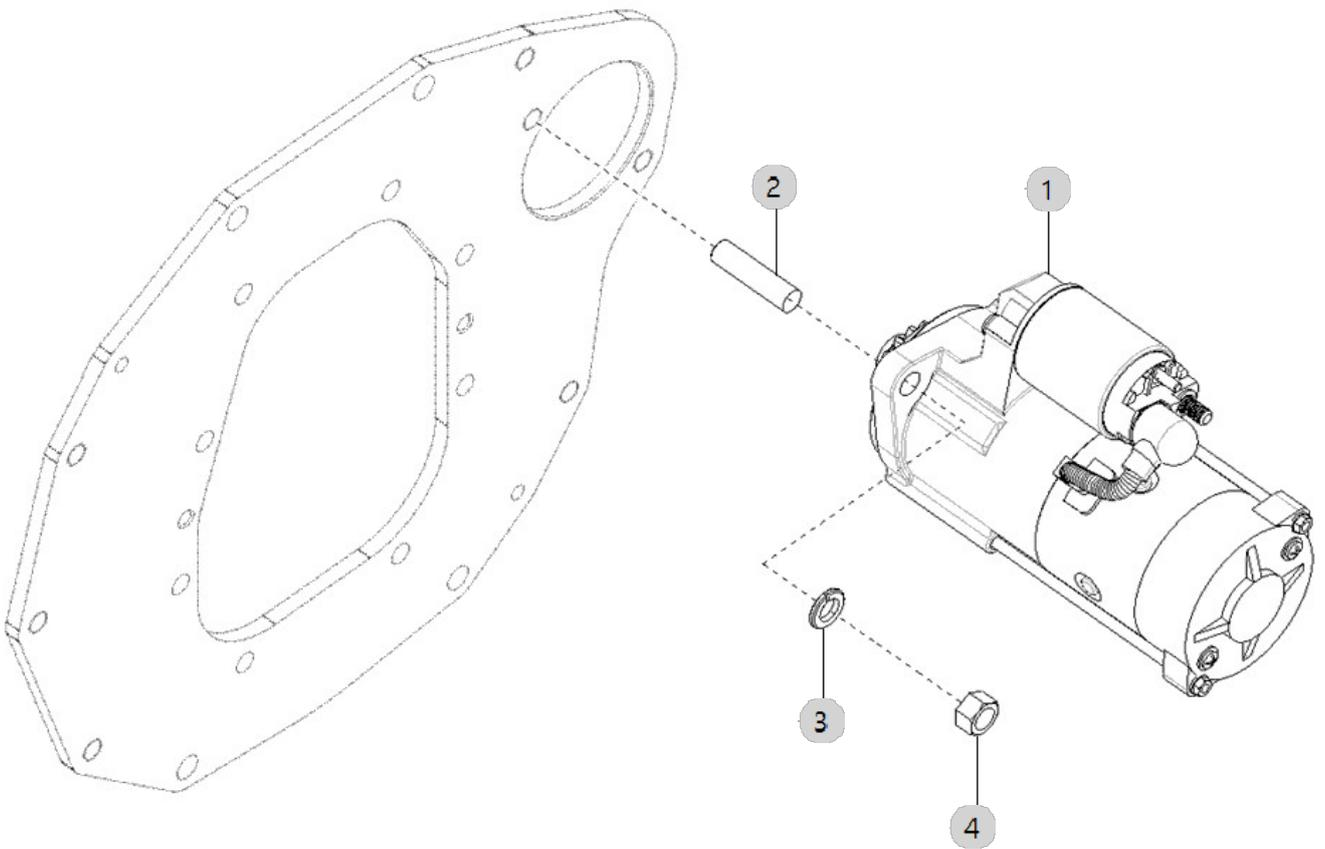

A43_001

A2300T3-ETC_5
(AB00333)

DPF SUPPORT OPTION

Year/Month

2022-12-19

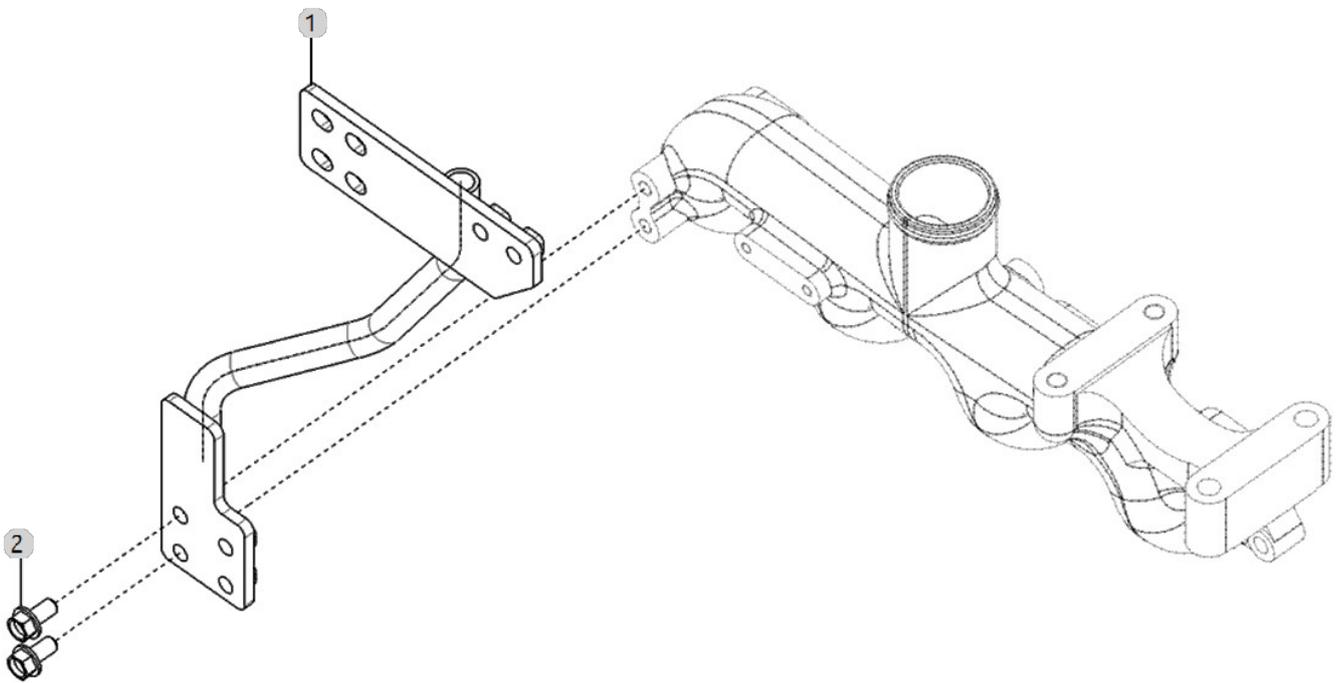

A44_008

A2300T3-ETC_5
(AB00333)

DPF MOUNTING OPTION

Year/Month

2022-12-19

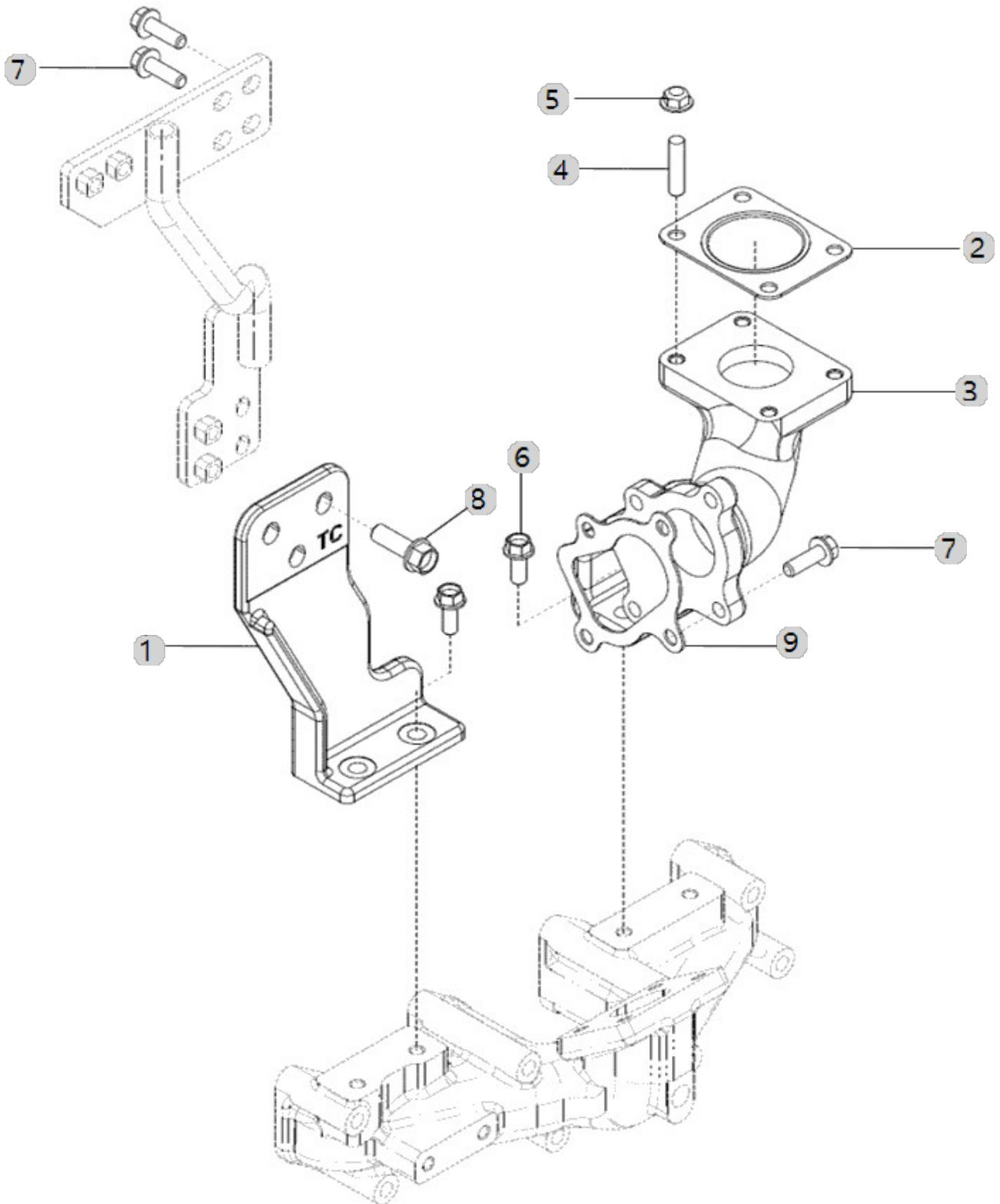

A45_012

A2300T3-ETC_5
(AB00333)

DPF

Year/Month

2022-12-19

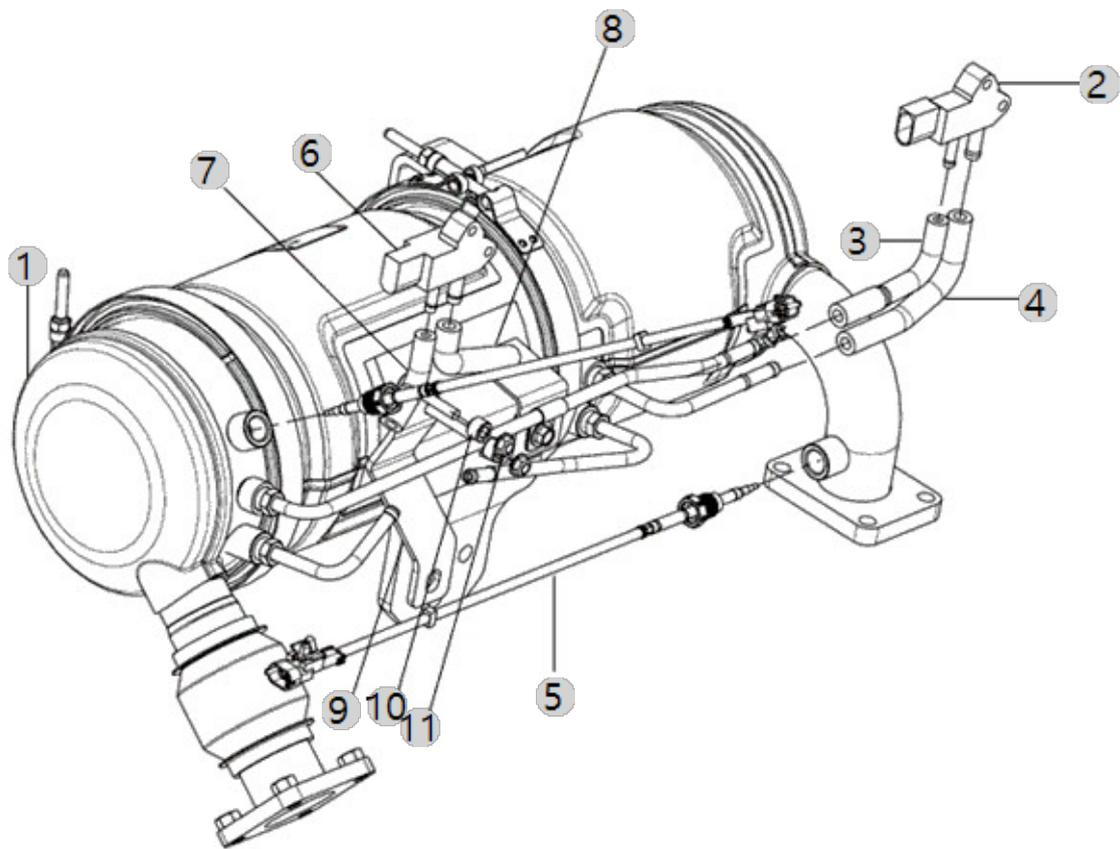

A48_006

A2300T3-ETC_5
(AB00333)

V-BELT

Year/Month

2022-12-19

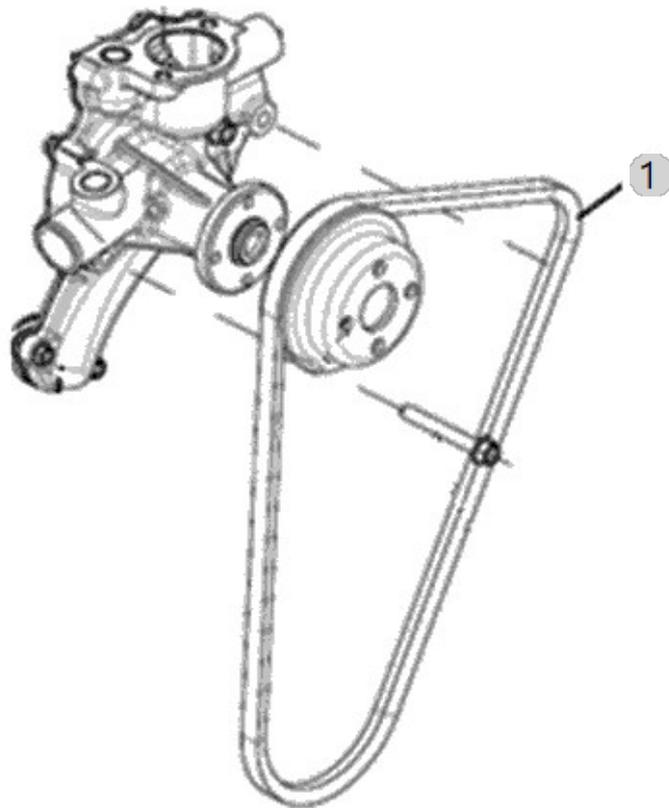

A50_001

A2300T3-ETC_5
(AB00333)

COMPRESSOR BRACKET ASS'Y

Year/Month

2022-12-19

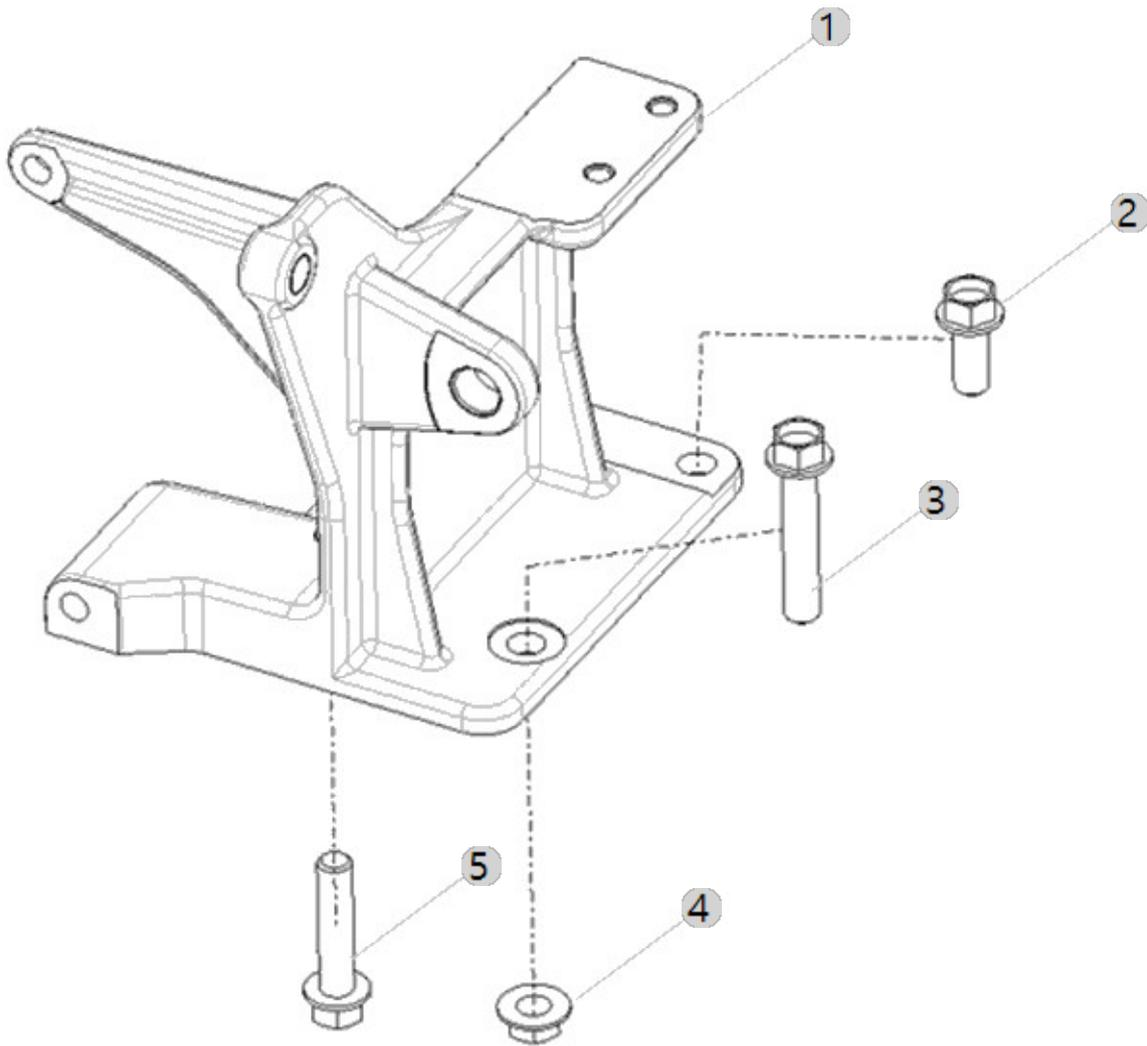

A51_006

A2300T3-ETC_5
(AB00333)

INTAKE HOSE ASSY OPTION

Year/Month

2022-12-19

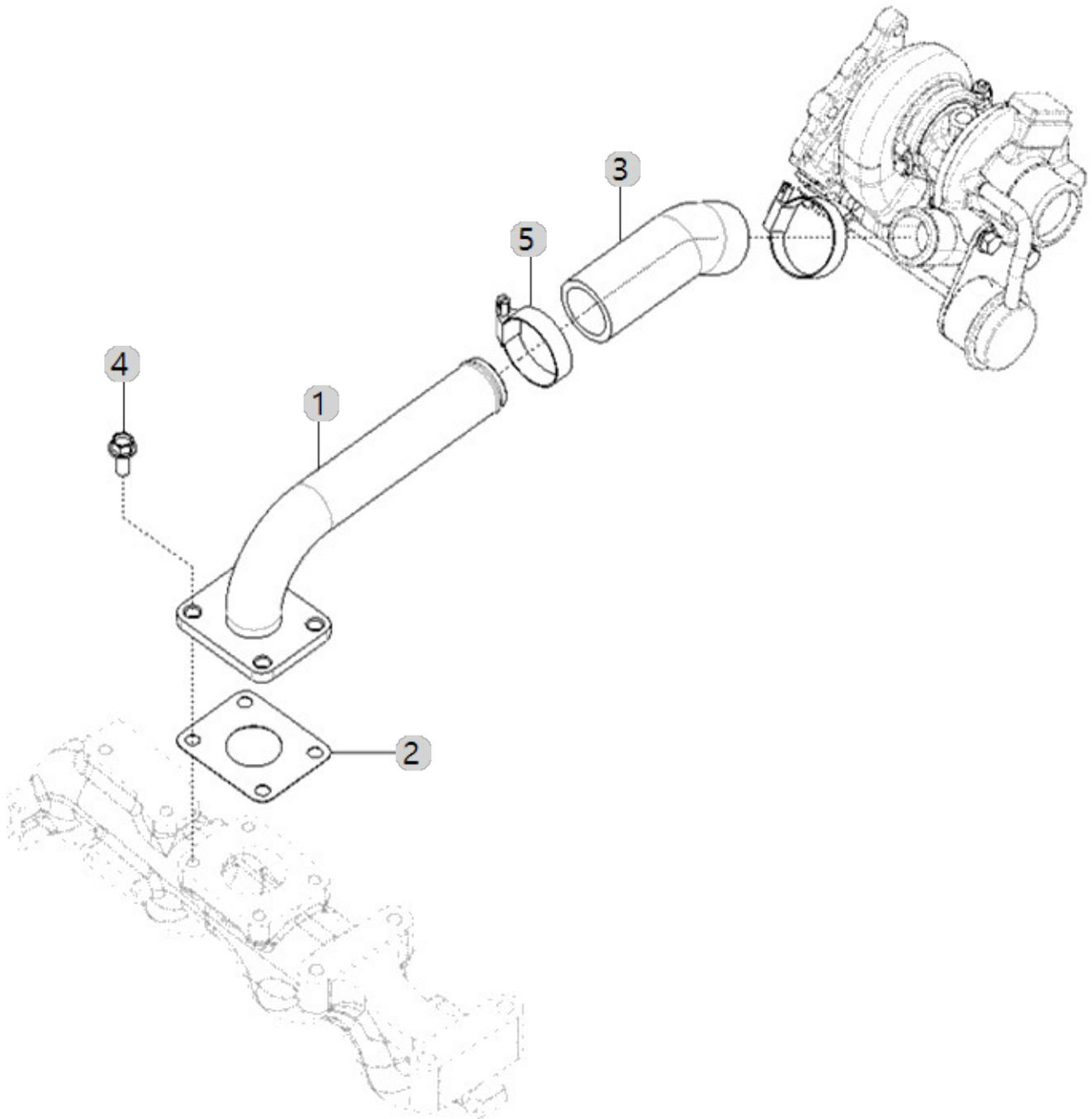

B01010

FUEL TANK

Year/Month

6225C(EU)(AC02123)

2022-12-19

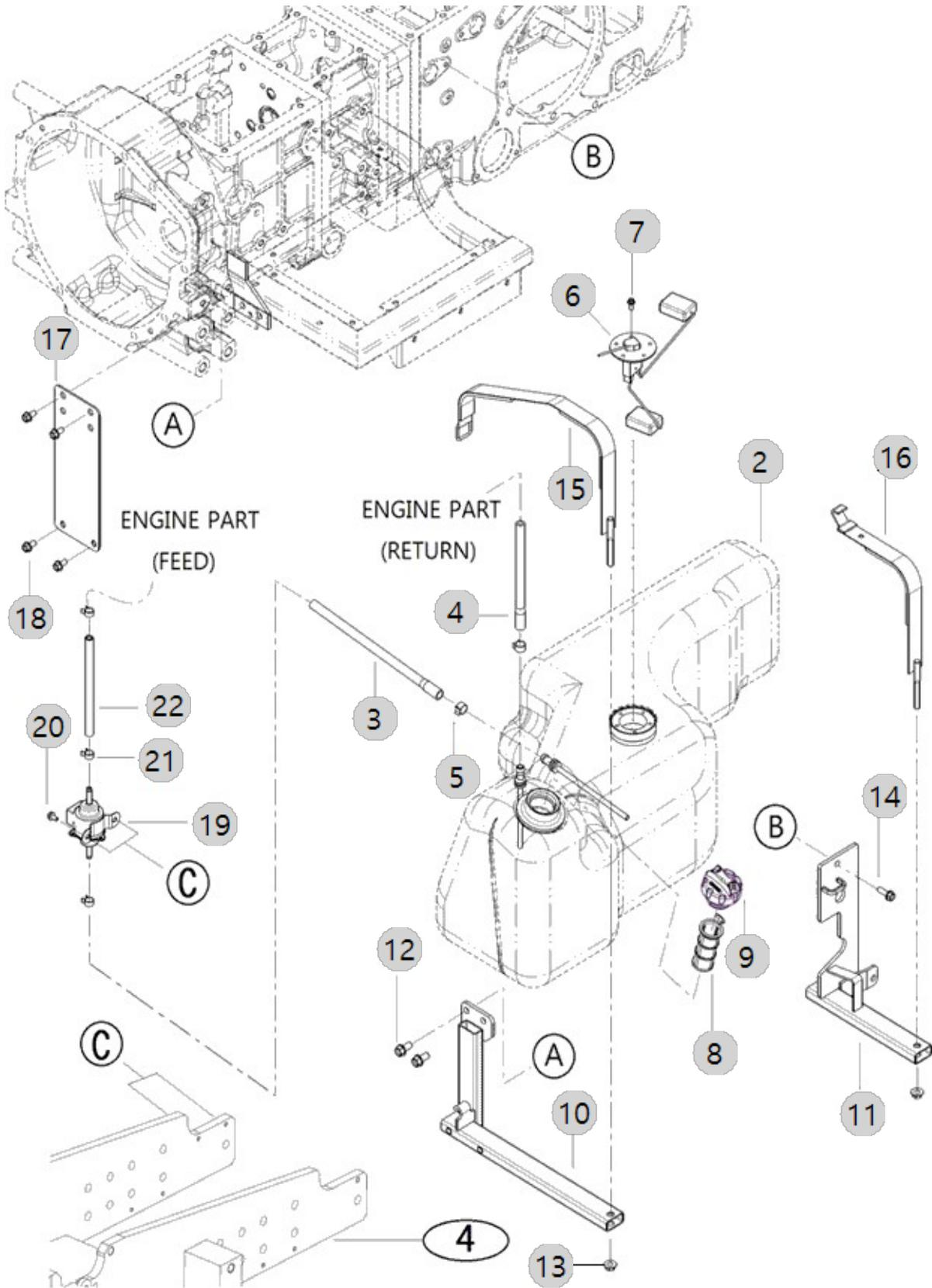

B02020

RADIATOR

Year/Month

6225C(EU)(AC02123)

2022-12-19

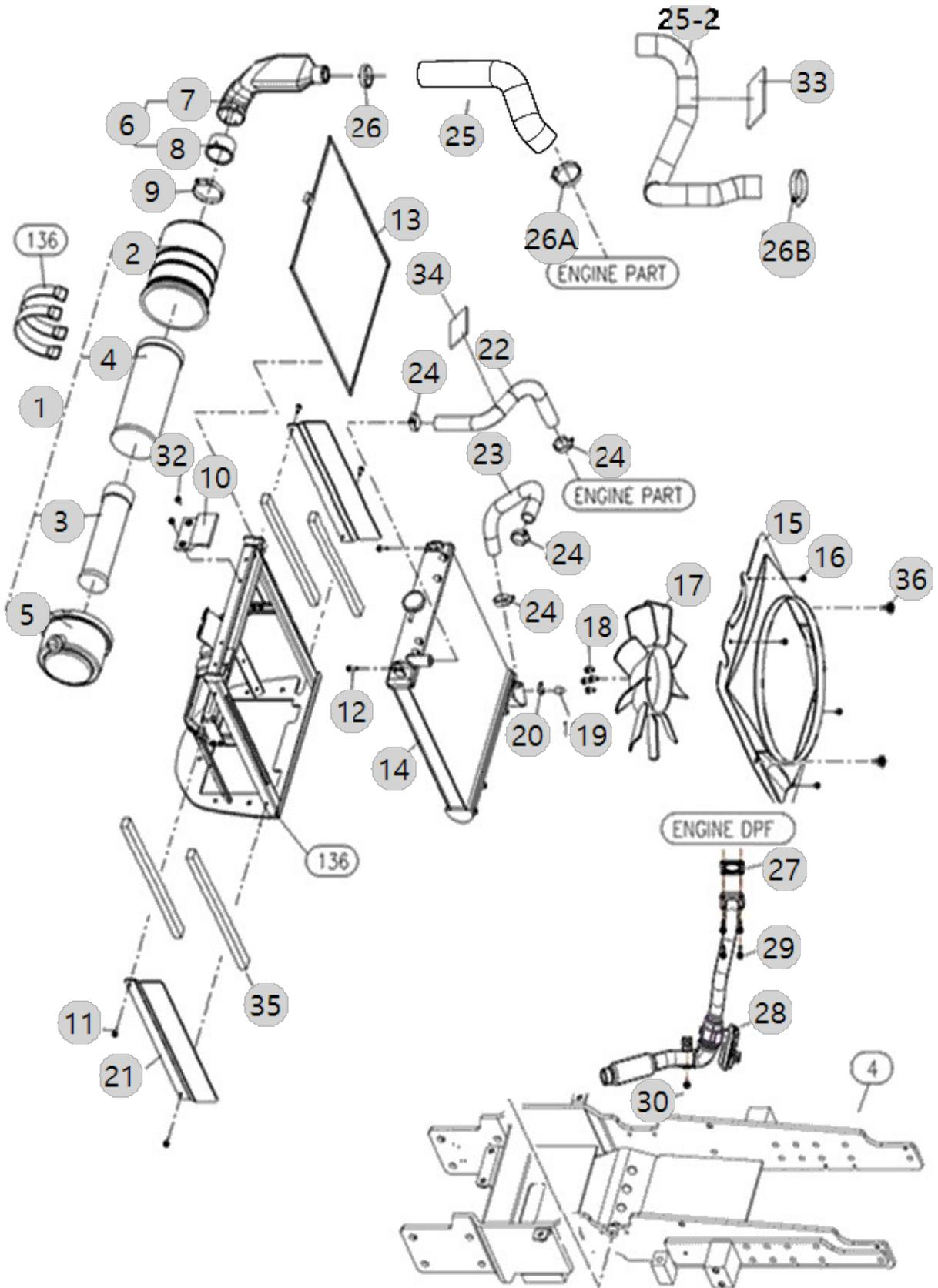

B02020		RADIATOR				Year/Month
6225C(EU)(AC02123)						2022-12-19
순번 (NO)	부품번호 (PART NO)	품명 (PART NAME)	품명 (PART NAME)	수량 (QTY)	규격 (SPEC)	비고 (REMARK)
1	HLT0621000A2	에어크리너 조합	AIRCLEANER ASSY	1		
2	HLT0621010A9	에어크리너본체	BODY, AIRCLEANER	1		
3	HLT0621020A9	에어크리너엘레먼트(외)	ELEMENT AIR CLEANER (OUTER)	1		
4	HLT0621030A9	에어크리너엘레먼트(내)	ELEMENT, AIR CLEANER (INNER)	1		
5	HLT0621040A9	커버(에어크리너)	COVER	1		
6	TA00034859A	흡기 파이프 조합	INTAKE PIPE ASSY	1		
7	TA00034847A	흡기 파이프	INTAKE PIPE	1		
8	TA00021622A	흡기파이프시일	SEAL	1	-	
9	23000-080000	호스클램프80	HOSECLAMP80	1	D80	
10	TA00025591A	방진 고무	CUSHION RUBBER	1		
11	26106-060162	육각플랜지 볼트	HEXFLANGBOLT	4	M6XP1.0X16	
12	26014-060252	와셔조립육각볼트(+SW,PW)	Bolt, Hexa (6-25)	2	M06X1.00X02	
13	TA00024833B	방진망	NET	1		
13	TA00024833C	방진망 조합	DUSTPROOF NET ASSY	1		
14	EA00003972A	라디에이터(3.5mm피치)	RADIATOR	1		
15	TA00032760F	슈라우드	SHROUD	1		
16	HRA1203200A4	태핑나사	TAPPINGSCREW	4		
17	TA00043900A	냉각팬	FAN	1		
18	26106-080162	플랜지볼트8X16	SCREW,HEXFLANGEHEADCAP	4	M8XP1.25X16	
19	HRC1201200A4	오일쿨러캡	CAP,COOLER	1		
20	23000-016000	호스클립	Clip, Hose (Φ16)	1	D16	
21	TA00049446A	라디에이터브래킷 조합	BRACKET ASS'Y, RADIATOR	2		
21	TA00049446B	라디에이터브래킷 조합	BRACKET ASS'Y, RADIATOR	2		
22	TA00060727A	냉각수호스A	COOLING WATER HOSE A	1		
23	TA00025609C	냉각수 호스 (B)	HOSE IN COOLING	1		
24	23010-038000	호스밴드	HOSEBAND	4	D38	
25	TA00034848A	흡기 호스	INTAKE HOSE	1		
25	TA00072194A	흡기호스	INTAKE HOSE	1		
26	23000-054000	호스클램프54	HOSECLAMP54	2	D54	
26	23000-080000	호스클램프80	HOSECLAMP80	1	D80	
27	EA00004235A	가스켓(TC_IN)	GASKET(TC_IN)	1		
28	EA00005796C	전자식배기밸브ASS'Y(20(S))	ELECTRONIC EXHAUST VALVE ASS'Y	1		
28	EA00005796B	전자식배기밸브ASS'Y(20(S))	ELECTRONIC EXHAUST VALVE ASS'Y	1		
29	26106-080252	육각플랜지볼트	SCREW,HEXFLANGEHEADCAP	4	M8XP1.25X25	
30	26106-080122	육각플랜지볼트	Bolt, Hexa (8-12)	1	M8XP1.25X12	
32	26015-060162	와셔조립육각볼트(S+PW)	BOLT	2	M6XP1.0X16	
33	TA00036162C	흡기호스(Turbo)방열판	INSULATOR	3		
34	TA00036163C	냉각수 호스A 방열판	GUIDE(L),FOOT REST	1		
35	TA00036707A	시일(RD)	SEAL(RD)	4		
36	26106-080162	플랜지볼트8X16	SCREW,HEXFLANGEHEADCAP	2	M8XP1.25X16	

B05011

LEVER ACCELERATOR

Year/Month

6225C(EU)(AC02123)

2022-12-19

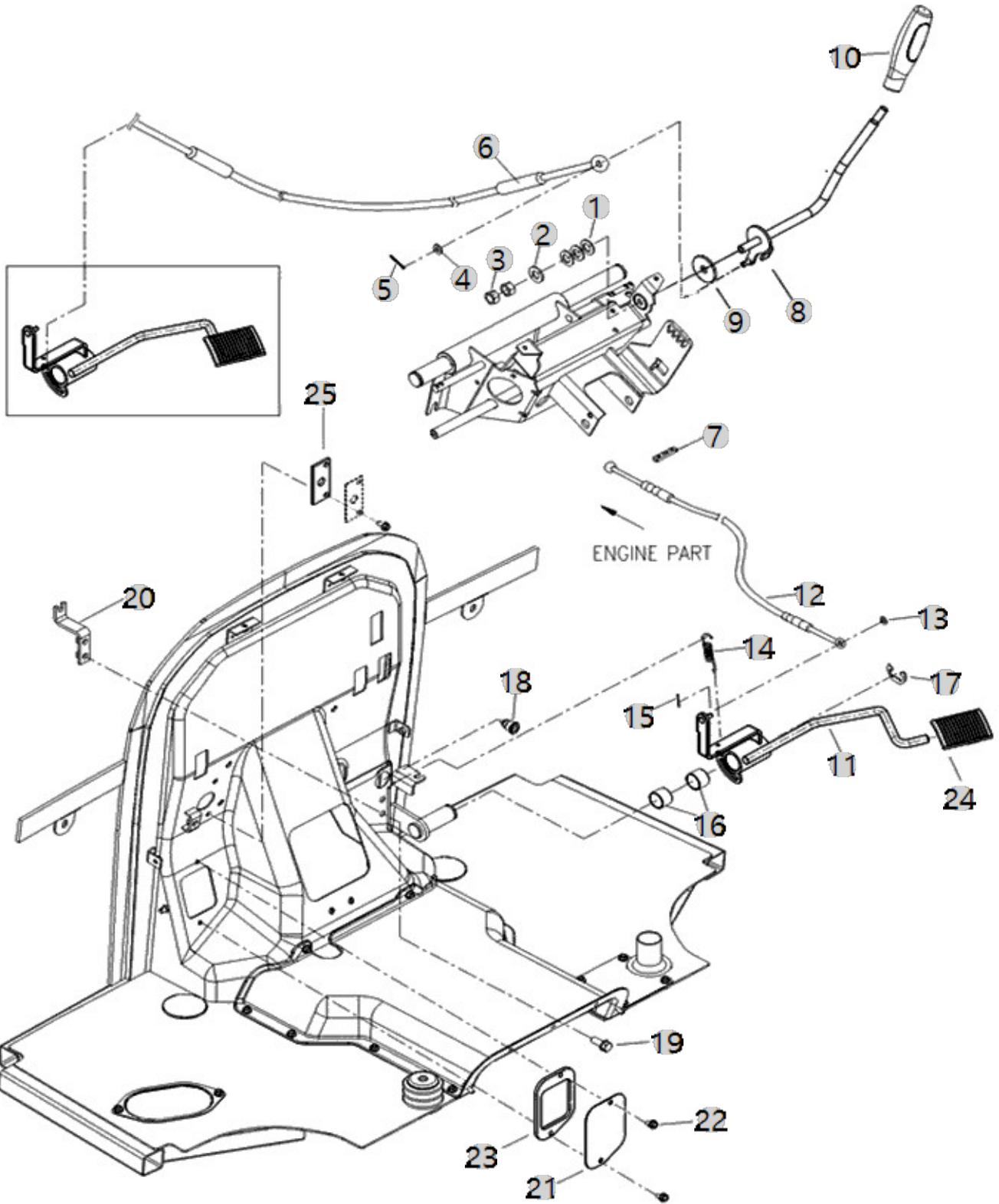

C01030

CLUTCH PEDAL

Year/Month

6225C(EU)(AC02123)

2022-12-19

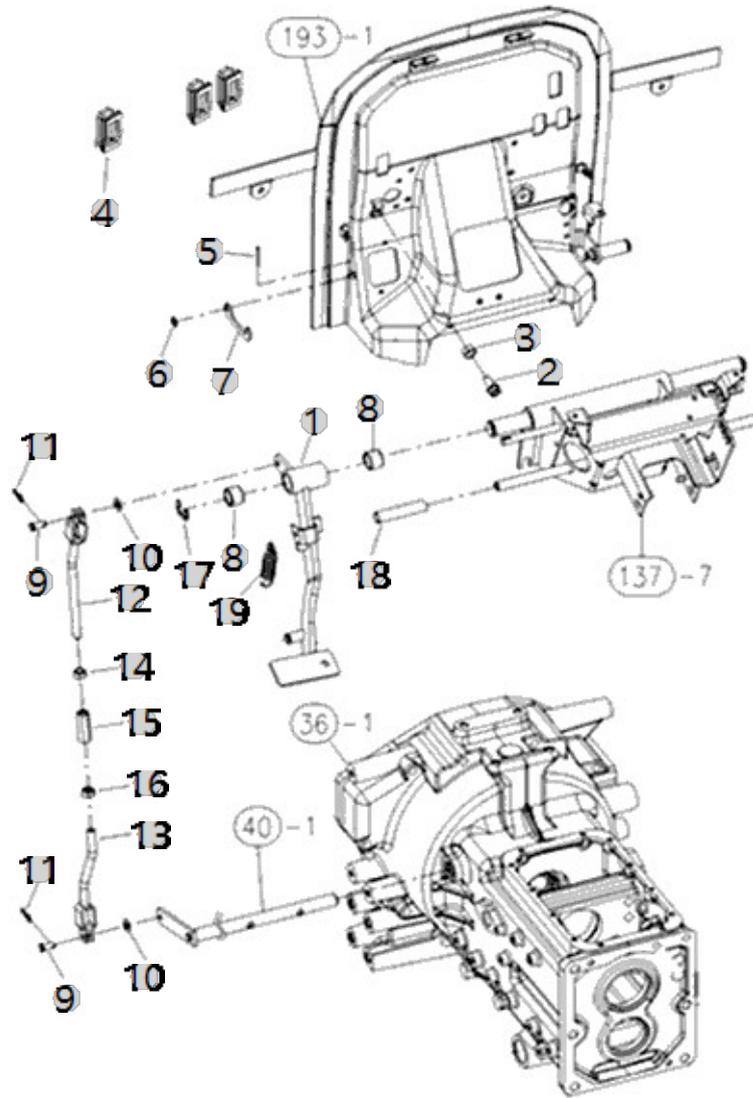

C02010

BRAKE PEDAL

Year/Month

6225C(EU)(AC02123)

2022-12-19

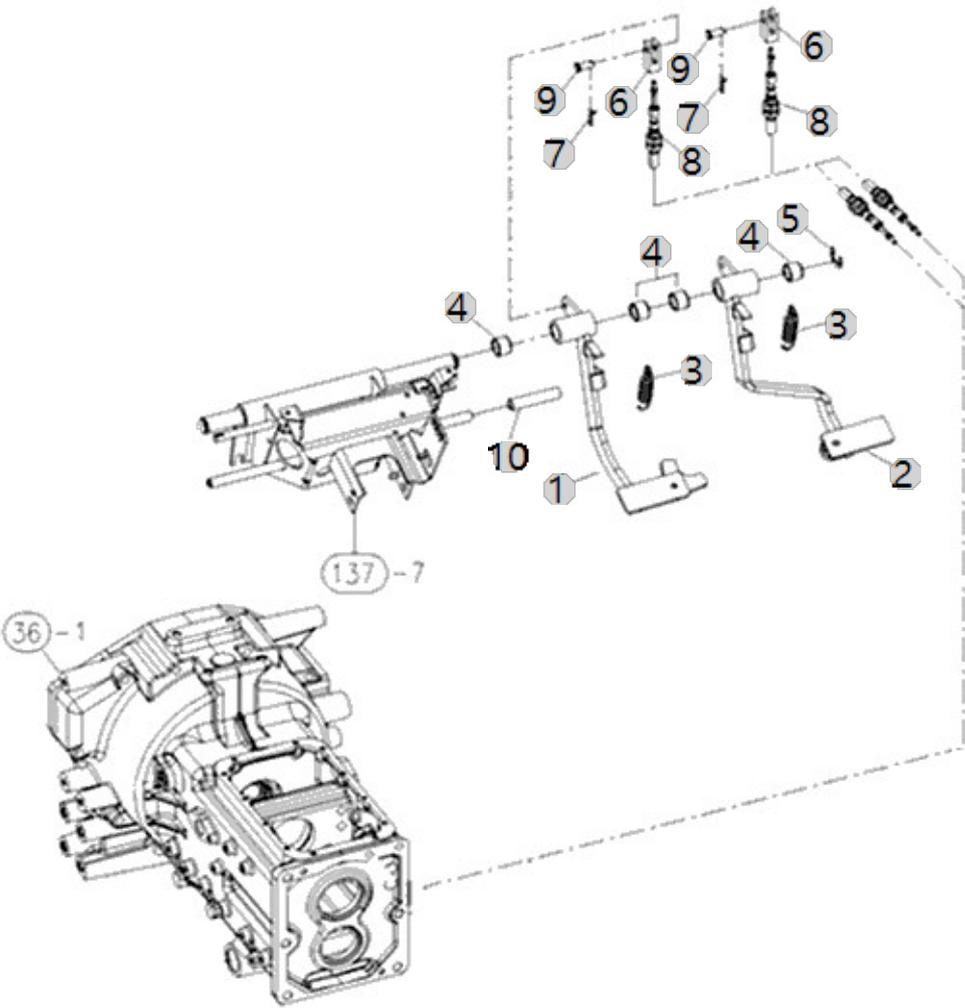

C02032

6225C(EU)(AC02123)

BRAKE LINK

Year/Month

2022-12-19

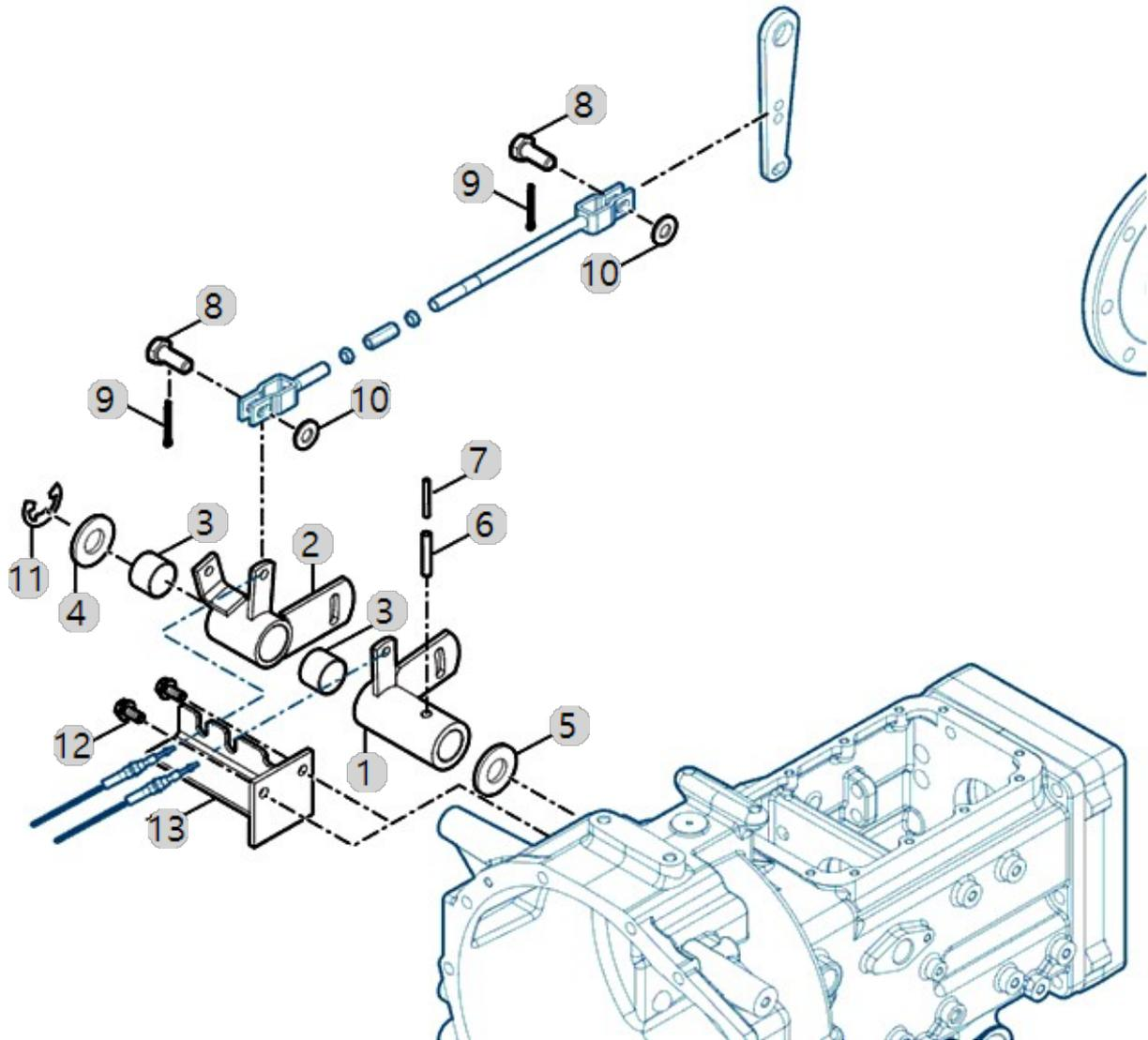

C02032 6225C(EU)(AC02123)	BRAKE LINK	Year/Month
		2022-12-19

순번 (NO)	부품번호 (PART NO)	품명 (PART NAME)	품명 (PART NAME)	수량 (QTY)	규격 (SPEC)	비고 (REMARK)
1	TA00017352C	브레이크 링크 (좌)후	BRAKE LINK (L), REAR	1		
1	TA00017352B	브레이크 링크 (좌)후	BRAKE LINE(L)REAR	1		
2	TA00017353D	브레이크 링크 (우)후	BRAKE LINK (R), REAR	1		
2	TA00017353C	브레이크 링크 (우)후	BRAKE LINE(R)REAR	1		
3	TB26240000A4	부시	BUSH	2	32X38X25	
4	TB35120000C4	와셔 B		1	2.3T	
5	TB35110000B4	와셔A	WASHER A	1	T1.2X50X50	
6	22351-080050	스프링핀	PIN, SPRING (8-50)	1		
7	22351-050050	스프링핀	PIN, SPRING (5-05)	1		
8	TT41090000C4	두부핀 10x23	PIN10X23	2	D10	
9	22417-200300	할핀	PIN , COTTER (2-30)	2	D2.0X30	
10	22137-100000	평와셔 10	WASHER, PLAIN (Φ 10)	2	M10	
11	22272-000240	스냅링	RING, CIRCLIP (Φ 24)	1	D24	
12	26106-100202	육각플랜지볼트	HEX BOLT, (10-20)	2	M10XP1.5X20	
13	TA00034254C	지지대 조합(R)	SUPPORT ASS'Y (R)	1		
13	TA00034254B	지지대 조합(R)	SUPPORT ASS'Y (R)	1		

C02050

PARKING BRAKE

Year/Month

6225C(EU)(AC02123)

2022-12-19

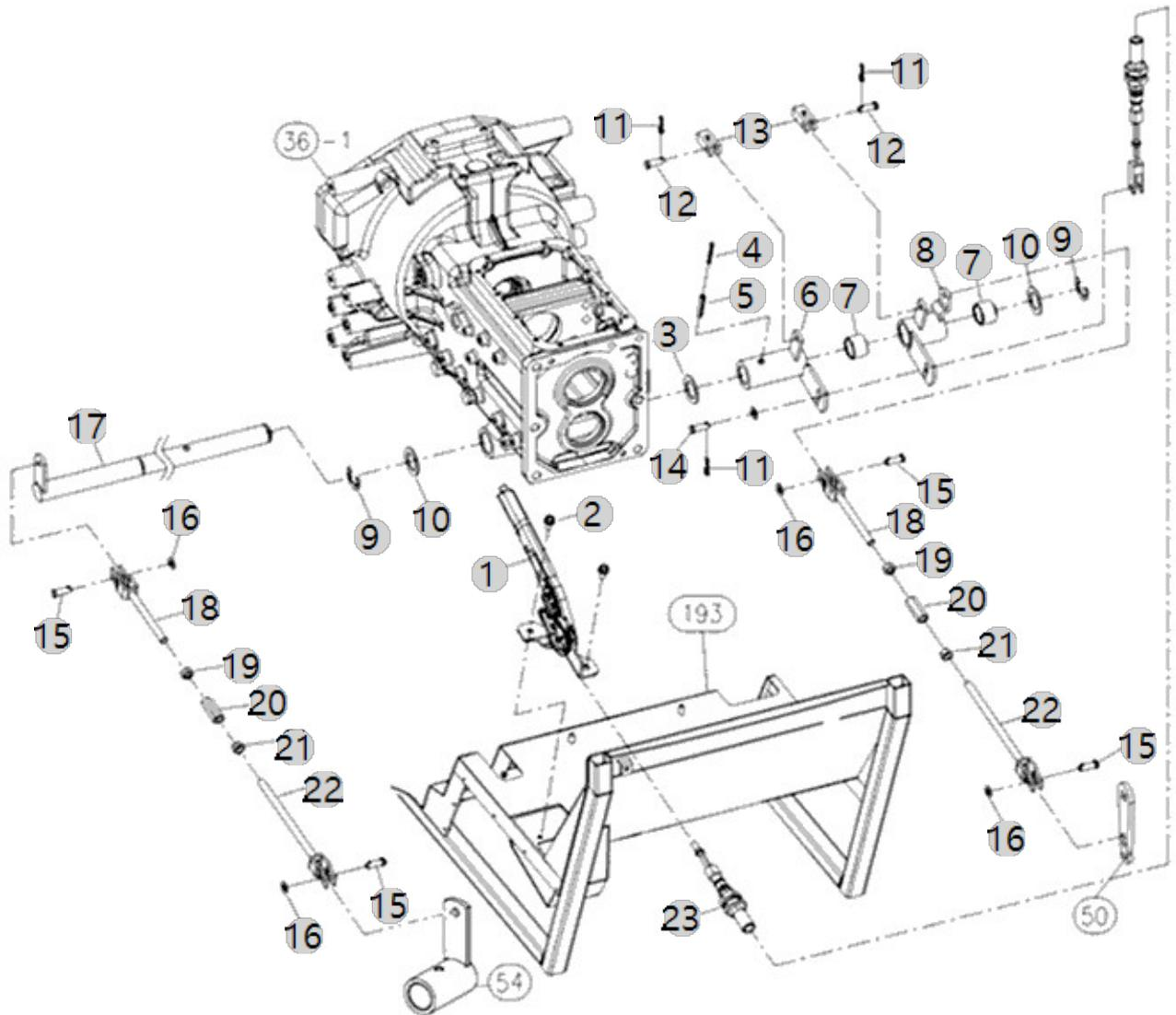

C02051

6225C(EU)(AC02123)

CABLE, PARKING BRAKE

Year/Month

2022-12-19

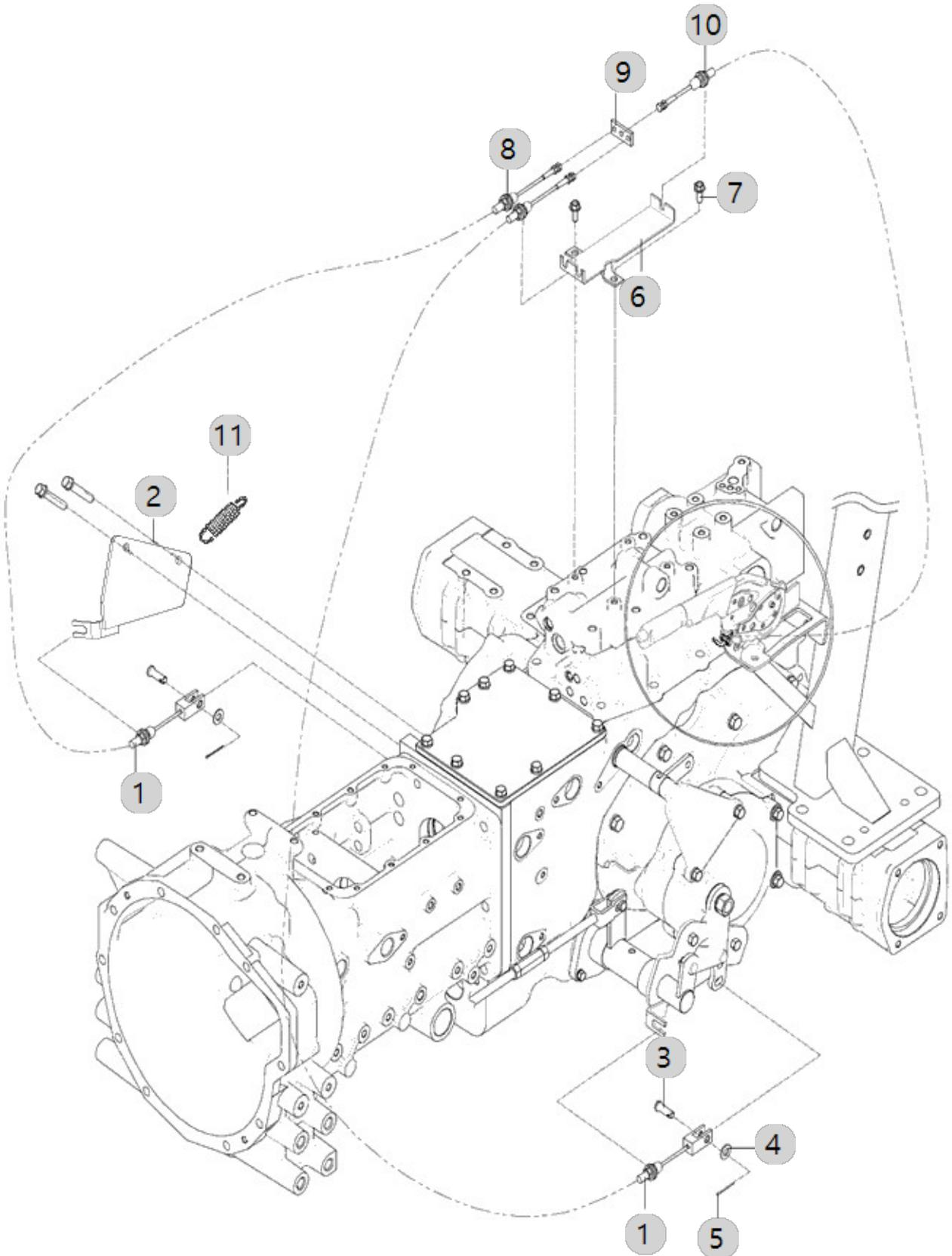

C02051	CABLE, PARKING BRAKE	Year/Month
6225C(EU)(AC02123)		2022-12-19

순번 (NO)	부품번호 (PART NO)	품명 (PART NAME)	품명 (PART NAME)	수량 (QTY)	규격 (SPEC)	비고 (REMARK)
1	TA00015989B	클레비스(SCV)	CLEVIS	2	19X19	
2	TA00036935D	브레이크 브래킷 조합	BRACKET, BRAKE	1		
2	TA00036935C	브레이크 브래킷 조합	BRACKET, BRAKE	1		
2	TA00036935E	브레이크 브래킷 조합	BRACKET, BRAKE	1		
3	TT41090000C4	두부핀 10x23	PIN10X23	2	D10	
4	22137-100000	평와셔 10	WASHER, PLAIN (Φ 10)	2	M10	
5	22417-200300	할핀	PIN , COTTER (2-30)	2	D2.0X30	
6	TA00036087B	브레이크 브래킷 조합	PARKING BRAKE ASS'Y	1		
6	TA00036087C	브레이크 브래킷 조합	PARKING BRAKE ASS'Y	1		
7	26106-080202	육각플랜지볼트	SQR FLANGE BOLT	2	M8XP1.25X20	
8	TA00028886C	주차브레이크와이어(L,R)	CABLE, PARKING BRAKE(L,R)	2	NONE	
9	TA00028944A	연결브래킷	BRACKET	1	4.5T	
9	TA00028944B	연결브래킷	BRACKET	1	4.5T	
10	TA00028887B	주차브레이크와이어(메인)	CABLE PARKING BRAKE(MAIN)	1	NONE	
11	FEB0150000D	본네트 고정 스프링	SPRING	1	D1.8	

C04010

SHUTTLE ASS'Y

Year/Month

6225C(EU)(AC02123)

2022-12-19

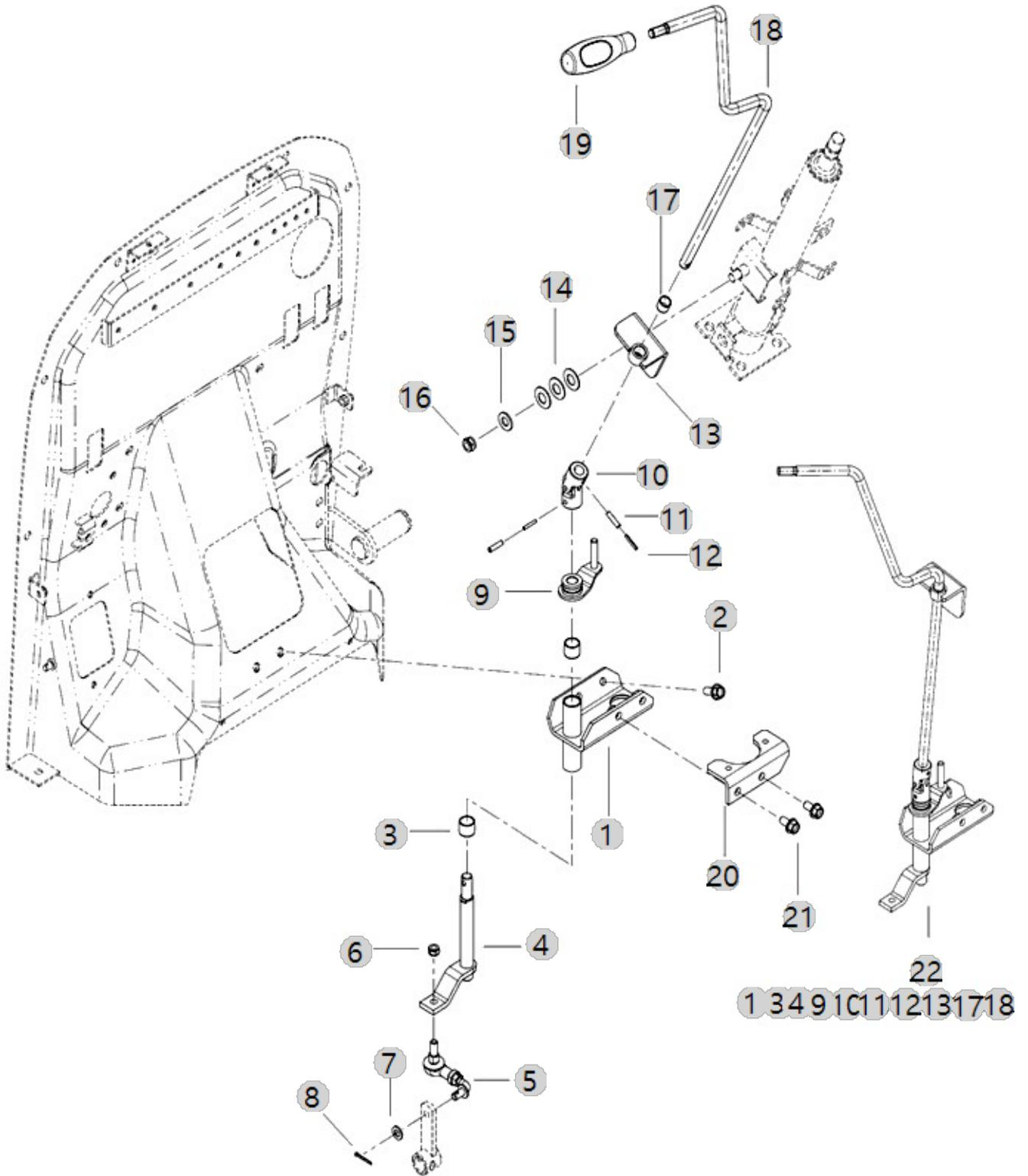

C04010	SHUTTLE ASS'Y		Year/Month	
6225C(EU)(AC02123)			2022-12-19	

순번 (NO)	부품번호 (PART NO)	품명 (PART NAME)	품명 (PART NAME)	수량 (QTY)	규격 (SPEC)	비고 (REMARK)
1	TA00017490D	리버서축 브래킷	BRACKET REVERSER SHAFT	1		
2	26106-080202	육각플랜지볼트	SQR FLANGE BOLT	2	M8XP1.25X20	
3	24550-016150	드라이부시	DRYBUSH	2		
4	TA00017487E	리버서축	SHAFT REVERSER	1		
5	TA00002832B	로드조합(F-R)	ROD ASS'Y(F-R)	1		
6	26347-080002	U너트	Unut	1	M8XP1.25	
7	22117-080000	평와셔(소형)	WASHER, PLAIN (Φ 08)	1	M8	
8	22417-250250	가름핀2.5X25	PIN, COTTER (2-25)	1	D2.5X25	
9	TA00017493B	조인트암 조합	JOINT ARM ASS'Y	1		
10	TA00060731A	조인트조합	JOINT ASS'Y	1		
11	22351-050020	스프링핀5X20	PIN, SPRING (5-20)	2	D5X20	
12	22351-030020	스프링핀3X20	PIN, SPRING (3X20)	2	D3X20	
13	TA00047045B	브래킷조합(셔틀레버)	BRACKET ASSY	1		
14	TC94060000A4	접시스프링12	PRING12	3		
15	22137-100000	평와셔 10	WASHER, PLAIN (Φ 10)	1	M10	
16	26347-100002	육각U너트	U-NUT	1	M10XP1.5	
17	24550-012120	드라이부시12X12	DRYBUSH12X12	1		
18	TA00047186D	셔틀레버(25series)	LEVER, SHUTTLE	1		
18	TA00047186C	셔틀레버(25series)	LEVER, SHUTTLE	1		
19	TA00056013A	셔틀 노브 조합(복미)	KNOB (LEVER SHUTTLE)	1		
20	TA00017502A	스위치취부판조합	SW BRACKET ASS'Y	1		
21	26106-080162	플랜지볼트8X16	SCREW,HEXFLANGEHEADCAP	2	M8XP1.25X16	
22	TA00047637D	리버스레버조합(캐빈/25)	REVERSE RLEVER ASSY (CABIN)	1		

C04031

LEVER, MAIN SHIFT

Year/Month

6225C(EU)(AC02123)

2022-12-19

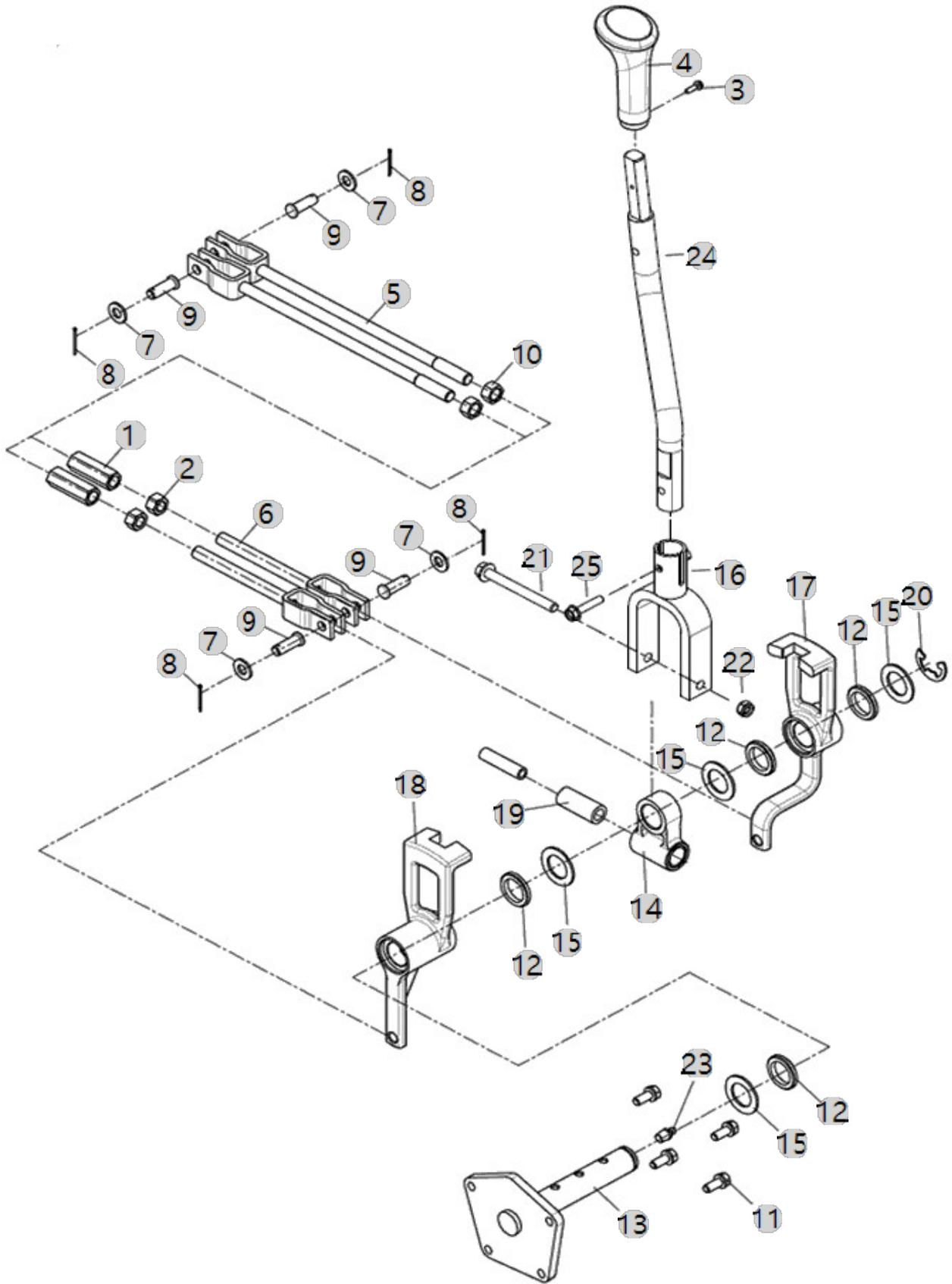

C04041

DIFF-LOCK PEDAL

Year/Month

6225C(EU)(AC02123)

2022-12-19

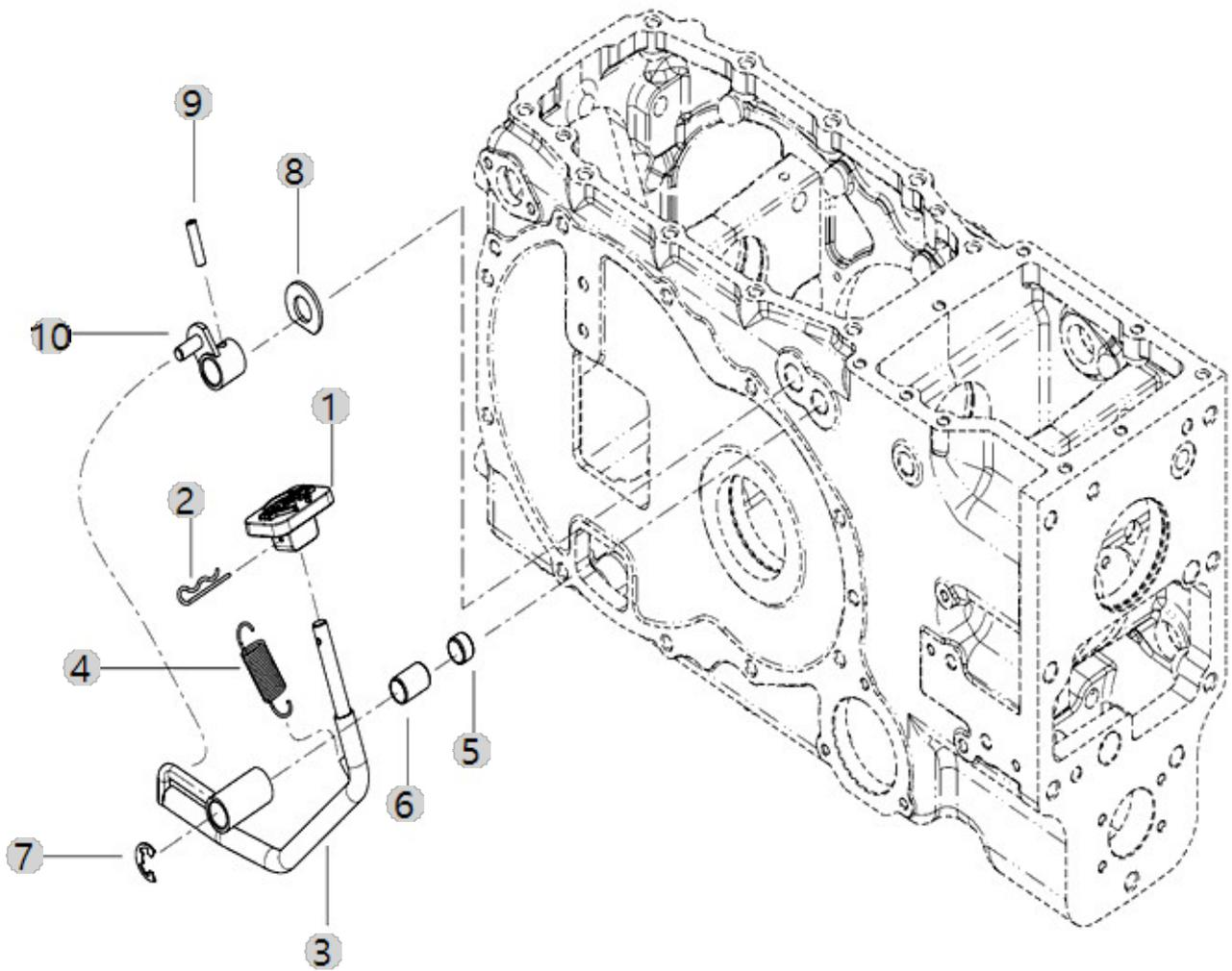

C04060

SCV LEVER

Year/Month

6225C(EU)(AC02123)

2022-12-19

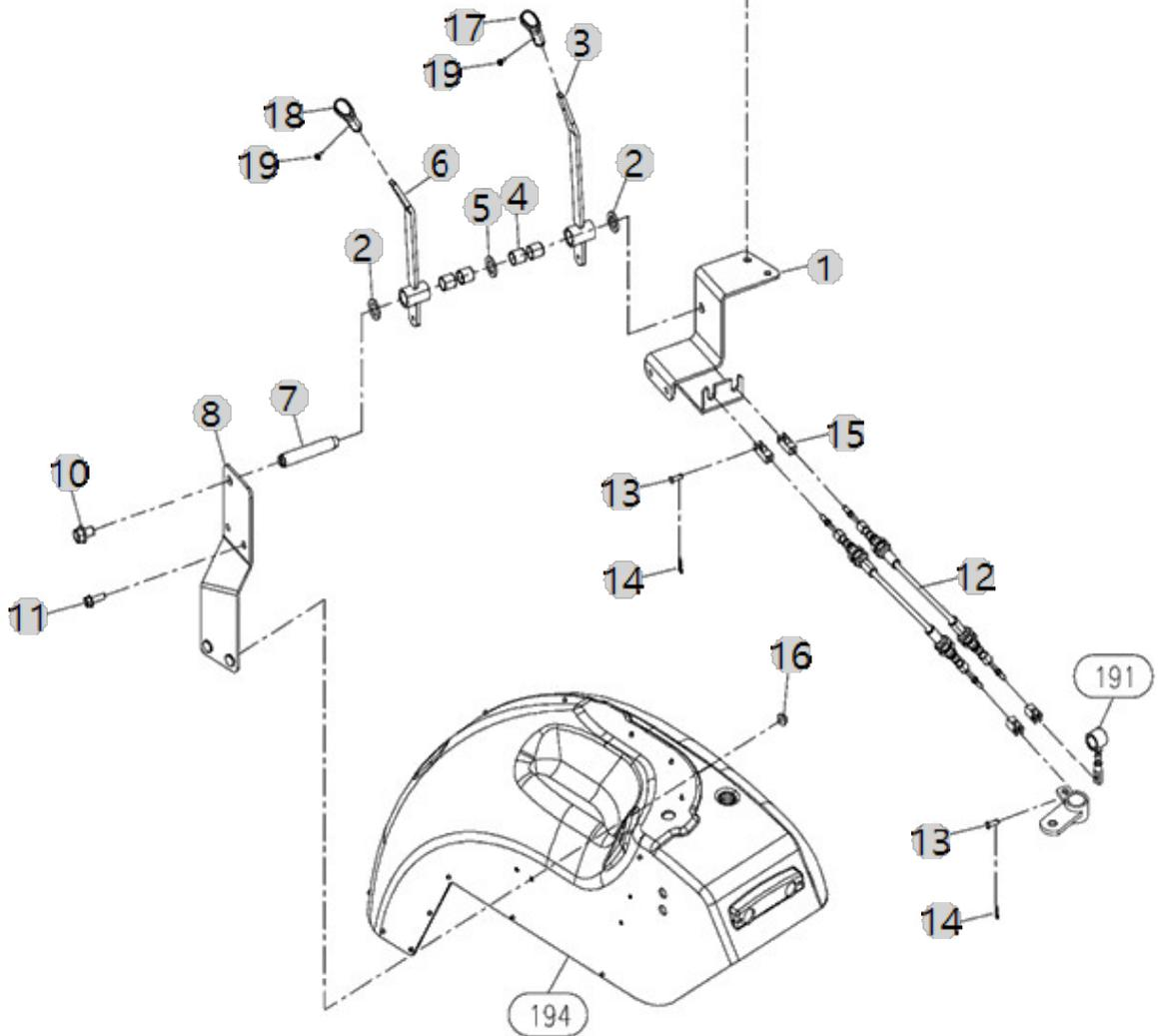
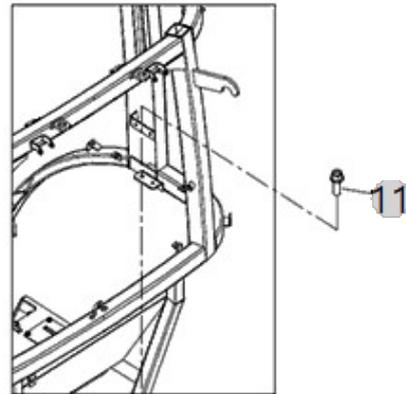
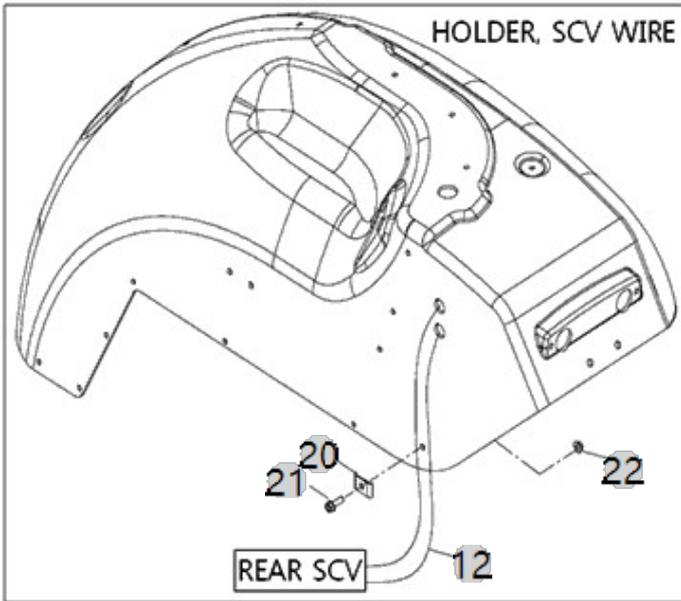

C04060		SCV LEVER				Year/Month
6225C(EU)(AC02123)						2022-12-19
순번 (NO)	부품번호 (PART NO)	품 명 (PART NAME)	품 명 (PART NAME)	수량 (QTY)	규격 (SPEC)	비고 (REMARK)
1	TA00028676A	scv 레버 브래킷 조합	SCV LEVER BRACKET ASS'Y	1		
2	TTB119000A4	플레이트	PLATE	2	3.0T	
3	TA00028682A	SCV 레버 1 조합	SCV LEVER 1 ASS'Y	1		
4	24550-018200	드라이부시	DRY BUSH	4	18X20	
5	TA00045507A	칼라	COLLOR	1		
6	TA00028685A	SCV 레버 2 조합	SCV LEVER 2 ASS'Y	1		
7	TA00028679A	축	SHAFT	1		
8	TA00028680A	SCV 레버 브래킷 A 조합	SCV LEVER BRACKET A ASS'Y	1		
10	26106-080122	육각플랜지볼트	Bolt, Hexa (8-12)	1	M8XP1.25X12	
11	26106-080252	육각플랜지볼트	SCREW,HEXFLANGEHEADCAP	4	M8XP1.25X25	
12	TA00036186A	SCV와이어	WIRE, REAR REMOTE	2		
13	22486-060140	두부핀	PIN, HEAD	4	D6X14	
14	22360-060000	스냅핀	PIN, SNAP (6Φ)	4	D6	
15	TA00015989B	클레비스(SCV)	CLEVIS	2	19X19	
16	26367-080002	259, 육각플랜지너트	HEX FLANGE NUT (Φ8)	2	M8XP1.25	
17	TA00022057A	SCV 1 노브조합	KNOB ASS'Y, SCV 1	1	-	
18	TA00022059A	SCV 2 노브조합	KNOB ASS'Y, SCV 2	1	-	
19	26023-040102	와셔조립납비작은나사(SW+PW)	SCREW W/WASHER	2	M4X10	
20	FB97250000B4	클램프	CLAMP	1		
20	FB97250000B4	클램프	CLAMP	1		
21	26106-080252	육각플랜지볼트	SCREW,HEXFLANGEHEADCAP	1	M8XP1.25X25	
22	26367-080002	259, 육각플랜지너트	HEX FLANGE NUT (Φ8)	1	M8XP1.25	

C04071

LEVER ASS'Y, PTO SPEED CHANGE

Year/Month

6225C(EU)(AC02123)

2022-12-19

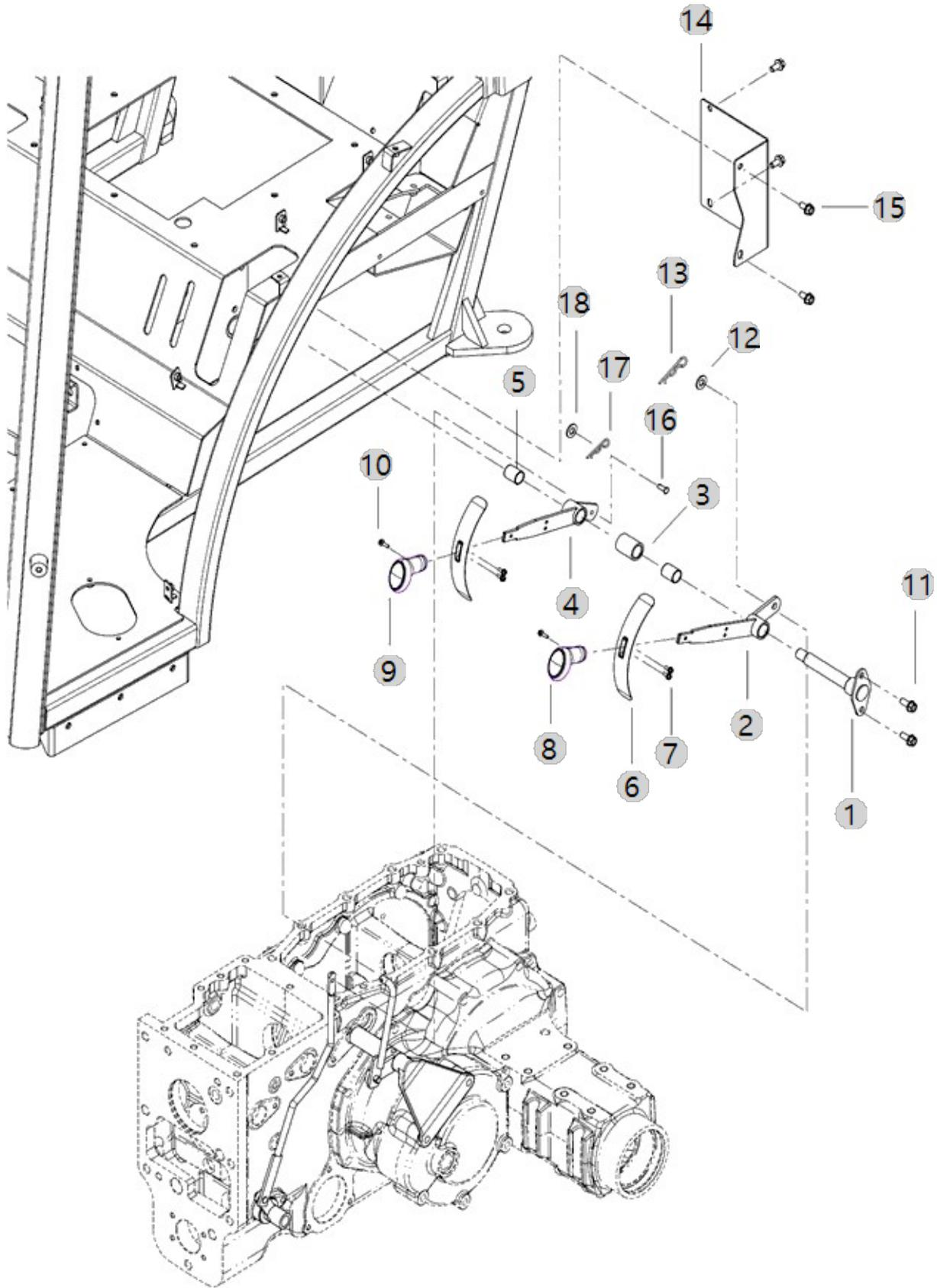

C04071 6225C(EU)(AC02123)	LEVER ASS'Y, PTO SPEED CHANGE	Year/Month
		2022-12-19

순번 (NO)	부품번호 (PART NO)	품 명 (PART NAME)	품 명 (PART NAME)	수량 (QTY)	규격 (SPEC)	비고 (REMARK)
1	TA00046818D	레버 축 조합(수출)	ASS'Y, LAVER SHAFT	1		
2	TA00046810C	PTO 레버(25_수출)	ASS'Y, LAVER	1		
2	TA00046810D	PTO 레버(25_수출)	PTO LEVER ASS'Y	1		
3	TA00046817A	간격 칼라	COLLAR	1		
4	TA00046807E	전륜구동 레버(25)	ASS'Y, LAVER	1		
4	TA00046807F	전륜구동 레버(25)	FWD LEVER ASS'Y	1		
5	24550-018250	드라이부시18X25	DRYBUSH	2	18X20X25	
6	TA00019913A	가이드	GUIDE	2		
7	26023-040122	SCREW4X12	SCREW 4X12	4		
8	TA00056007A	PTO노브조합	LEVER, PTO	1		
9	TA00062657A	전륜구동 노브 조합	LEVER, FRONT DRIVE KNOB	1		
10	26023-040122	SCREW4X12	SCREW 4X12	2		
11	26106-080202	육각플랜지볼트	SQR FLANGE BOLT	2	M8XP1.25X20	
12	22137-100000	평와셔 10	WASHER, PLAIN (Φ 10)	1	M10	
13	22360-100000	스냅핀 10	PIN , SNAP (10Φ)	1	D10	
14	TA00049154C	커버B(수출)	COVER	1		
14	TA00049154B	커버B(수출)	COVER	1		
15	26106-080162	플랜지볼트8X16	SCREW,HEXFLANGEHEADCAP	4	M8XP1.25X16	
16	22487-060120	두부핀 6X12	PIN, HEAD (06-12)	1	D6X12	
17	22360-080000	스냅핀8	PIN , SNAP (8Φ)	1	D8	
18	22137-080000	와셔8	WASHER, PLAIN (Φ 08)	1	M8	

D01010

HYD PUMP

Year/Month

6225C(EU)(AC02123)

2022-12-19

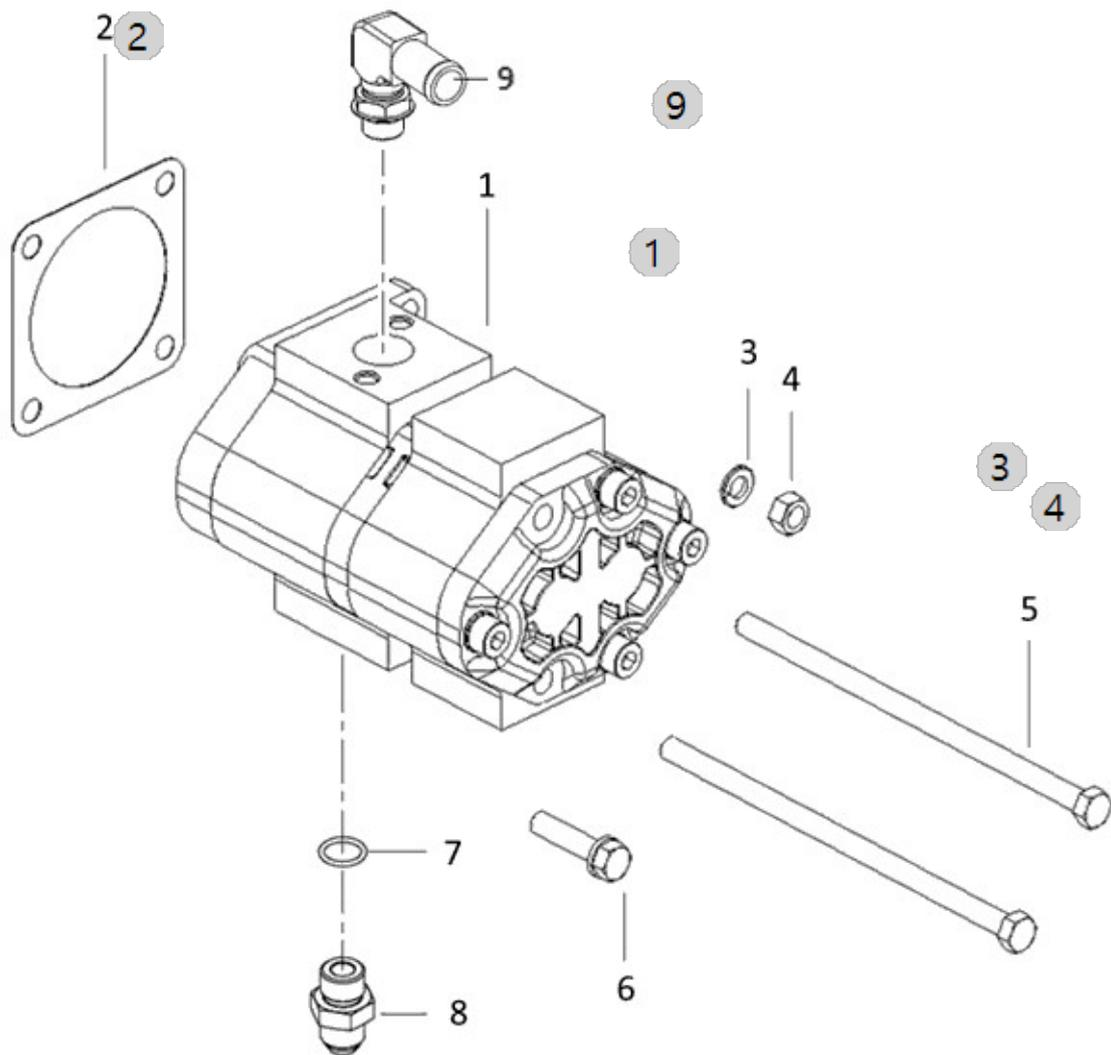

D01020B

LOW PRESSURE PIPE

Year/Month

6225C(EU)(AC02123)

2022-12-19

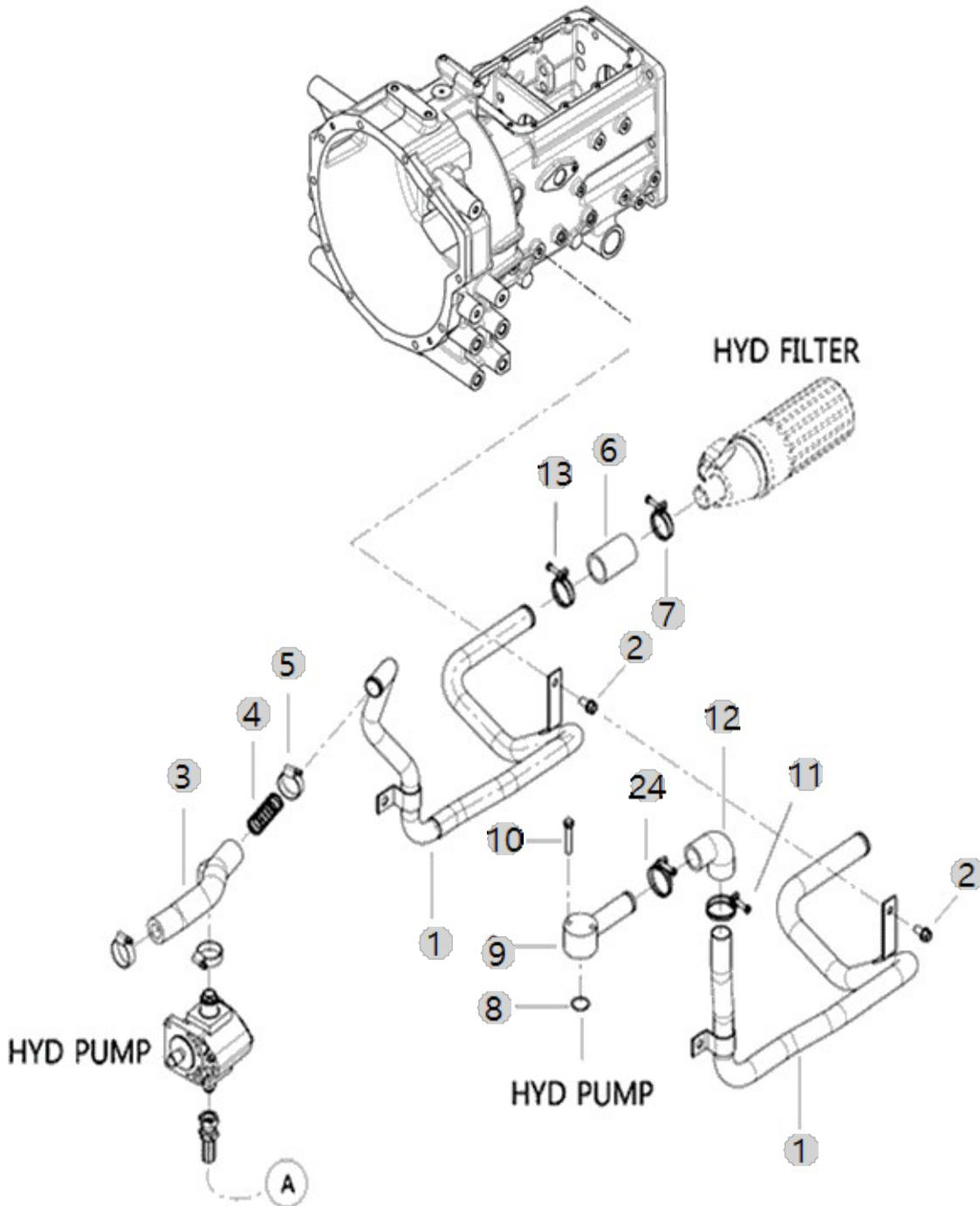

D01040

HYD FILTER

Year/Month

6225C(EU)(AC02123)

2022-12-19

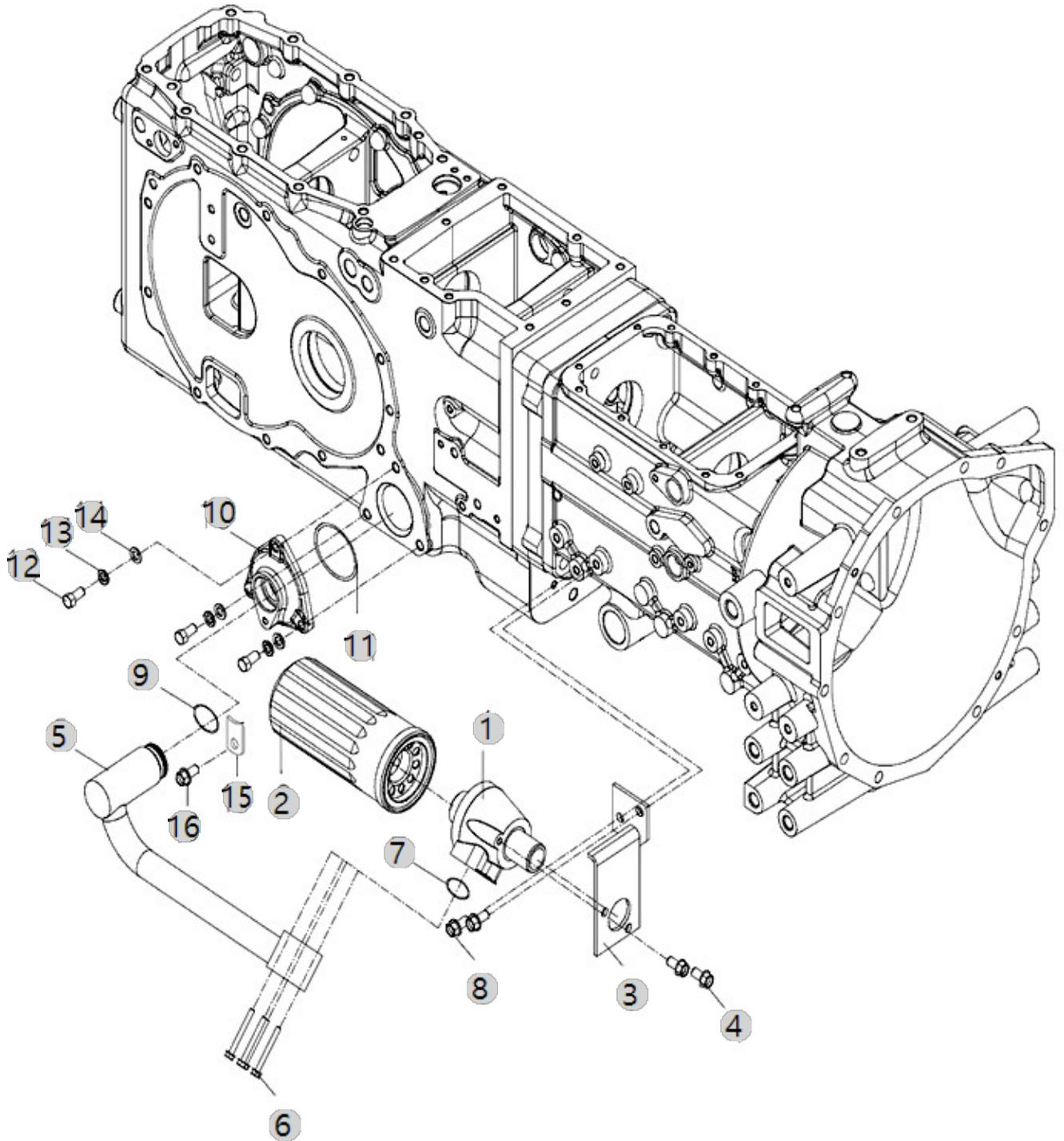

D01050

SCV VALVE

Year/Month

6225C(EU)(AC02123)

2022-12-19

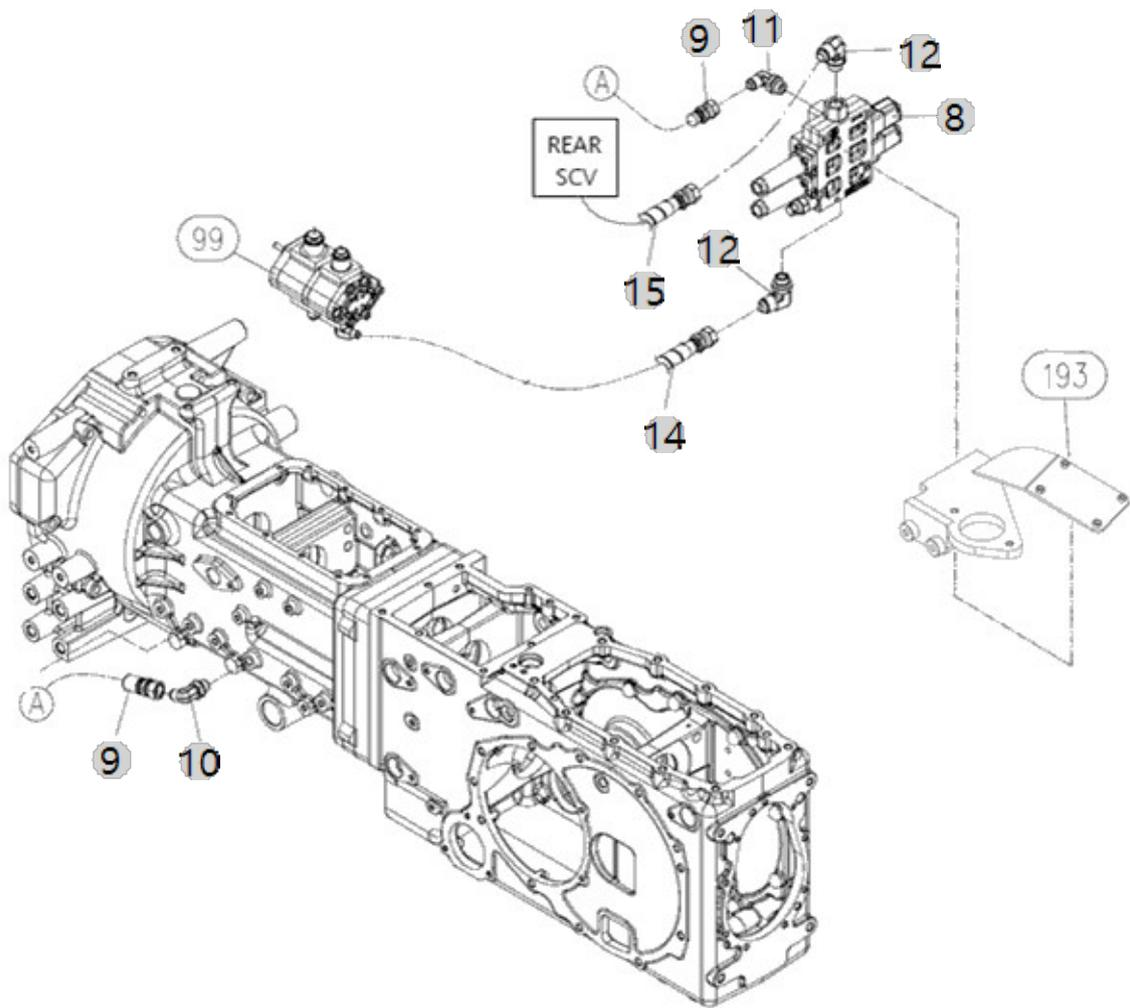

D02010

STEERING WHEEL

Year/Month

6225C(EU)(AC02123)

2022-12-19

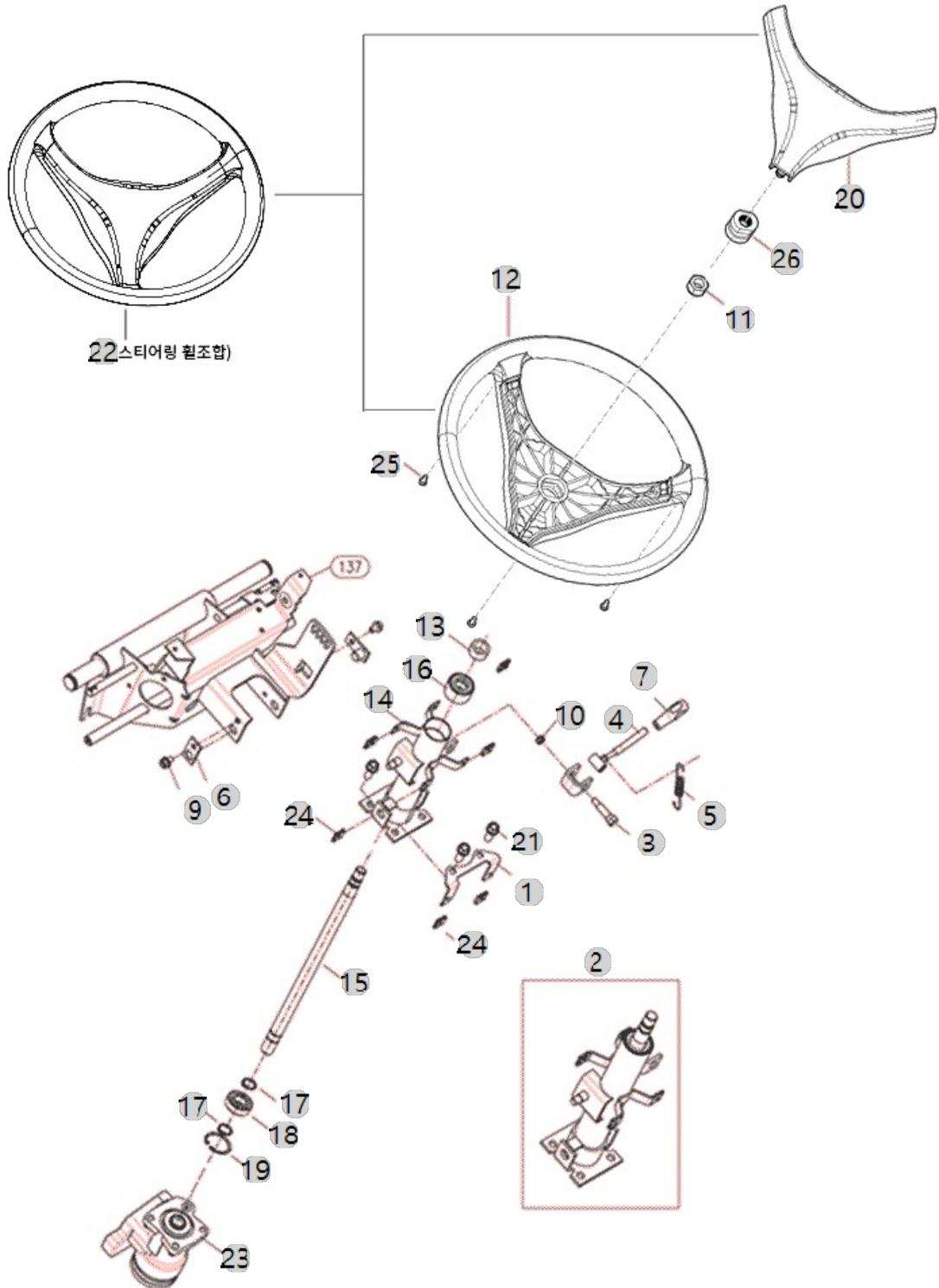

D02030

PST HOSE

Year/Month

6225C(EU)(AC02123)

2022-12-19

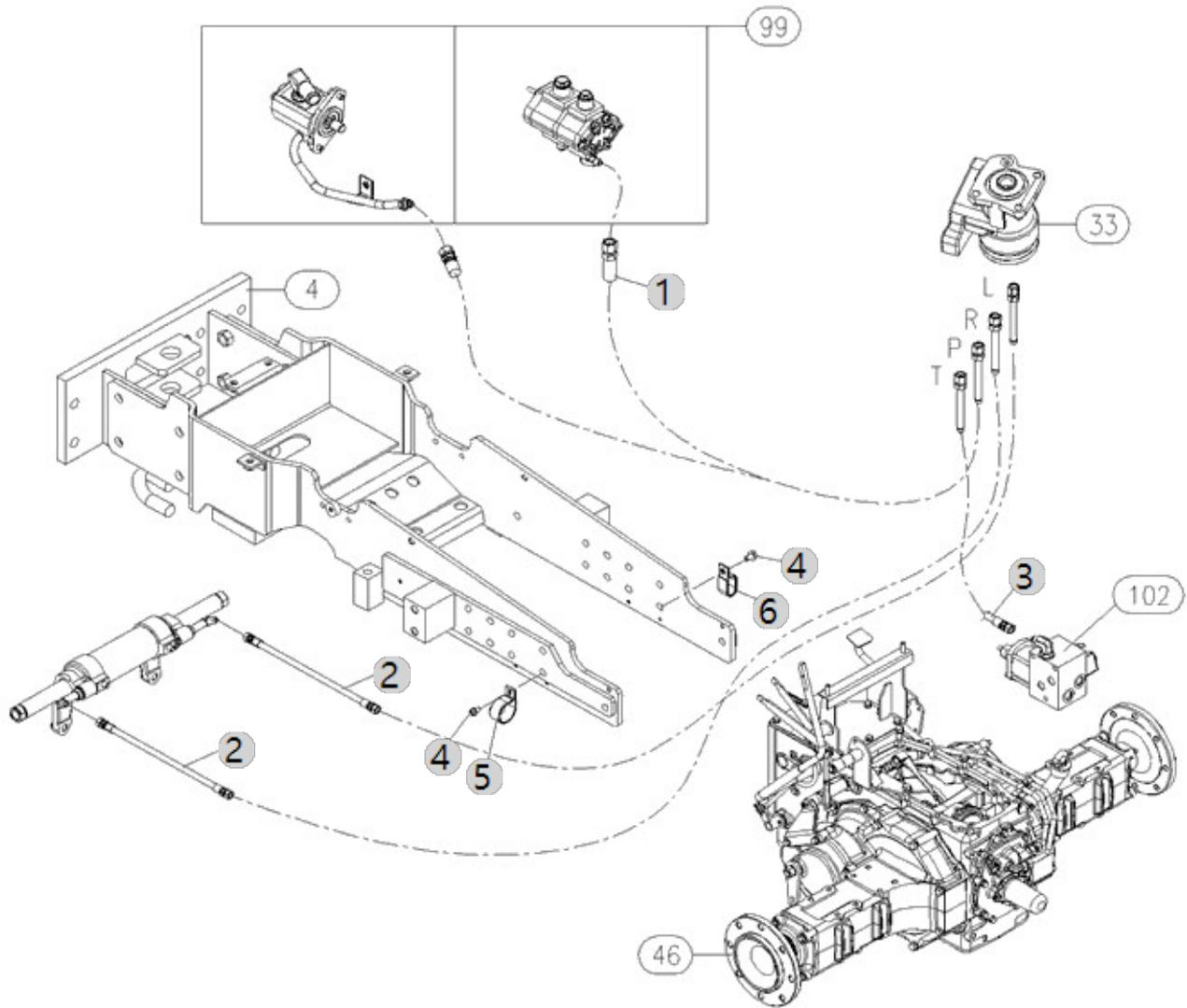

D02040

PST CYLINDER

Year/Month

6225C(EU)(AC02123)

2022-12-19

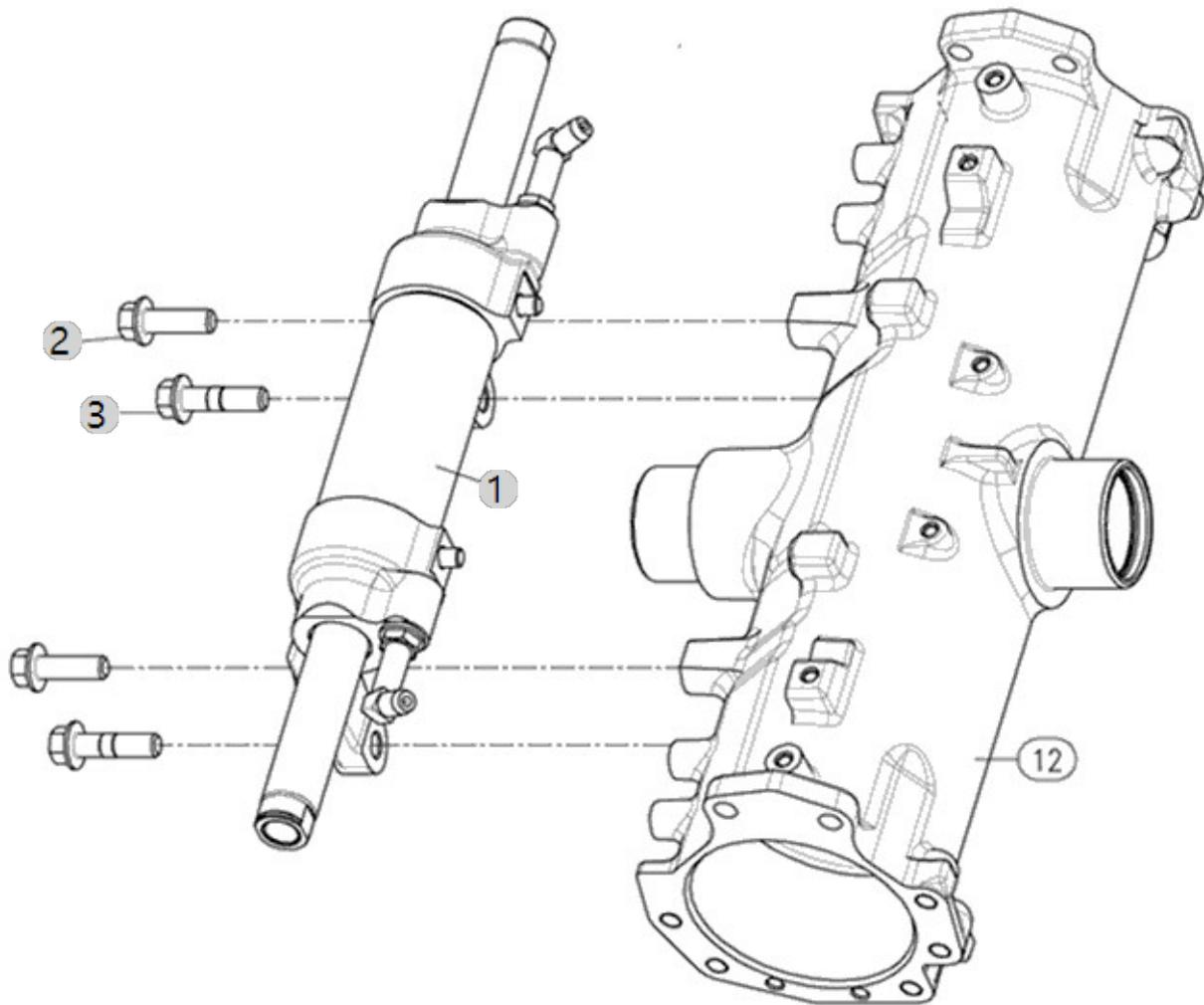

D04000

HYDRAULIC CYLINDER

Year/Month

6225C(EU)(AC02123)

2022-12-19

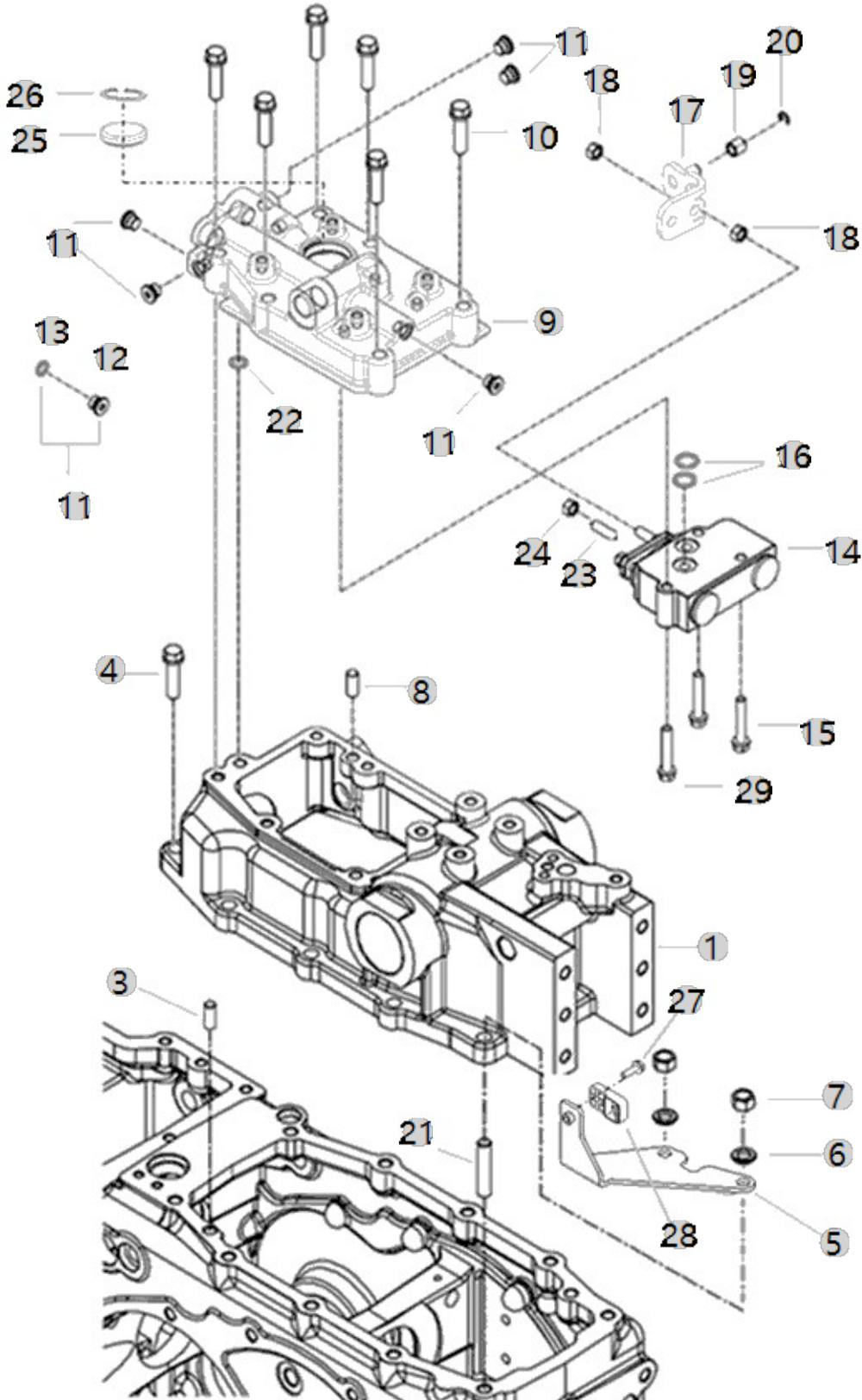

D04000		HYDRAULIC CYLINDER				Year/Month
6225C(EU)(AC02123)						2022-12-19
순번 (NO)	부품번호 (PART NO)	품명 (PART NAME)	품명 (PART NAME)	수량 (QTY)	규격 (SPEC)	비고 (REMARK)
1	TA00033085J	유압실린더케이스	HYD CYLINDER CASE	1		
3	22312-100180	평행핀	PIN, DOWEL (10-18)	1	D10X18	
4	26013-120352	와셔조립육각볼트(+SW)	SCREW,CAPTIVEWASHERCAP	5	M12XP1.75X0	
5	TA00060049B	스위치브래킷	SWITCH BRACKET	1		
5	TA00060049A	스위치브래킷	BRACKET ASSY	1		
6	22217-120000	스프링와셔	WASHER, SPRING (Φ 12)	5	M12	
7	26716-120002	295,ALL,육각너트	HEXA NUT295	5	M12X1.75	
8	22312-100200	평행핀	PIN, DOWEL (10-20)	2	D10X20	
9	TA00033096H	유압실린더 커버	COVER, HYD CYLINDER	1		
10	26013-100452	와셔조립육각볼트	HEX BOLT W/WASHER	6	M10X1.5X45	
11	TA00045690B	플러그조합	PLUG ASSY	5		
12	TA00045685A	플러그	PLUG	5		
13	24311-000080	O-링 495-8	O-RING, DYNAMIC (Φ8)	5	P8	
14	TA00033098C	승하강밸브	VALVE, CONTROL	1		
15	26013-080452	와셔조립육각볼트(+SW)	SCREW,CAPTIVEWASHERCAP	2	M8XP1.25X45	
16	24315-000160	운동용O링	O-RING	2		
17	TA00060775A	클레비스	CLEVIS	1		
18	26711-080002	육각너트	NUT	2	M8XP1.25	
19	TA00033126A	롤러	ROLLER	1		
20	22272-000060	SNAP RING	RING, CIRCLIP (Φ 06)	1	D6	
21	26216-120352	심음보울트	STEELBOLT	5	M12X1.75	
22	24311-000120	O-링 495-12	O-RING, DYNAMIC (Φ12)	1	P12	
23	TA00060360A	가이드 볼트	BOLT, GUIDE	1		
24	26716-080002	육각너트	NUT,HEX (D8)	1	M8xP1.25	
25	27260-400000	실링캡	SEALING CAP	1		
26	22252-000400	서어클립40	RING, CIRCLIP (Φ 40)	1	D40	
27	26106-060202	육각플랜지볼트(6*20)	HEXFLANGE BOLT	1	M6X1.0X20	
28	HA00001435A	리프트센서(무접점)조합	LIFT SENSOR	1		
29	26106-080402	451,ALL,플랜지볼트	SCREW,HEXFLANGEHEADCAP	1		

E01010

FRONT AXLE CASE

Year/Month

6225C(EU)(AC02123)

2022-12-19

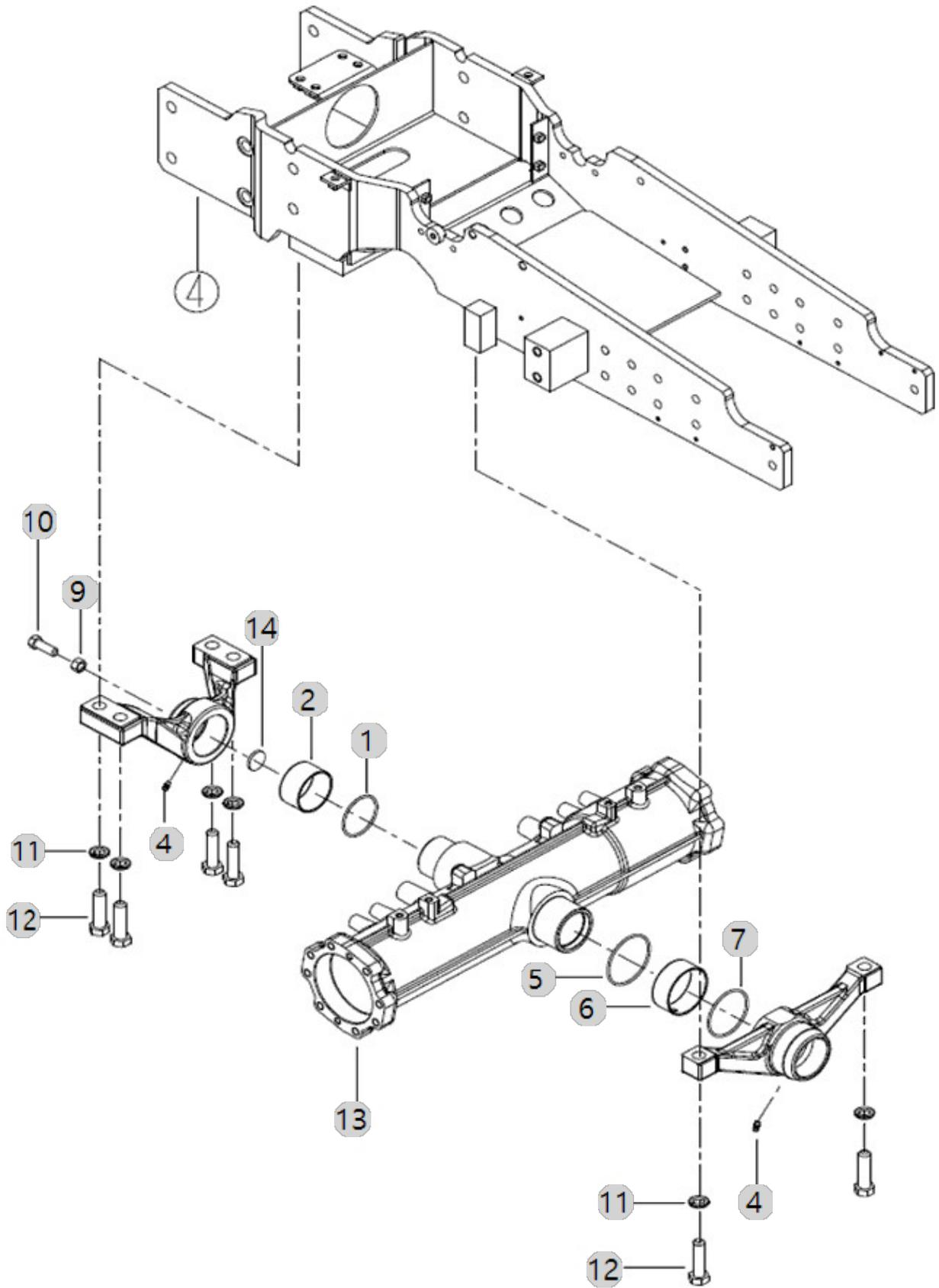

E01013

6225C(EU)(AC02123)

FRONT AXLE CASE/SPACER

Year/Month

2022-12-19

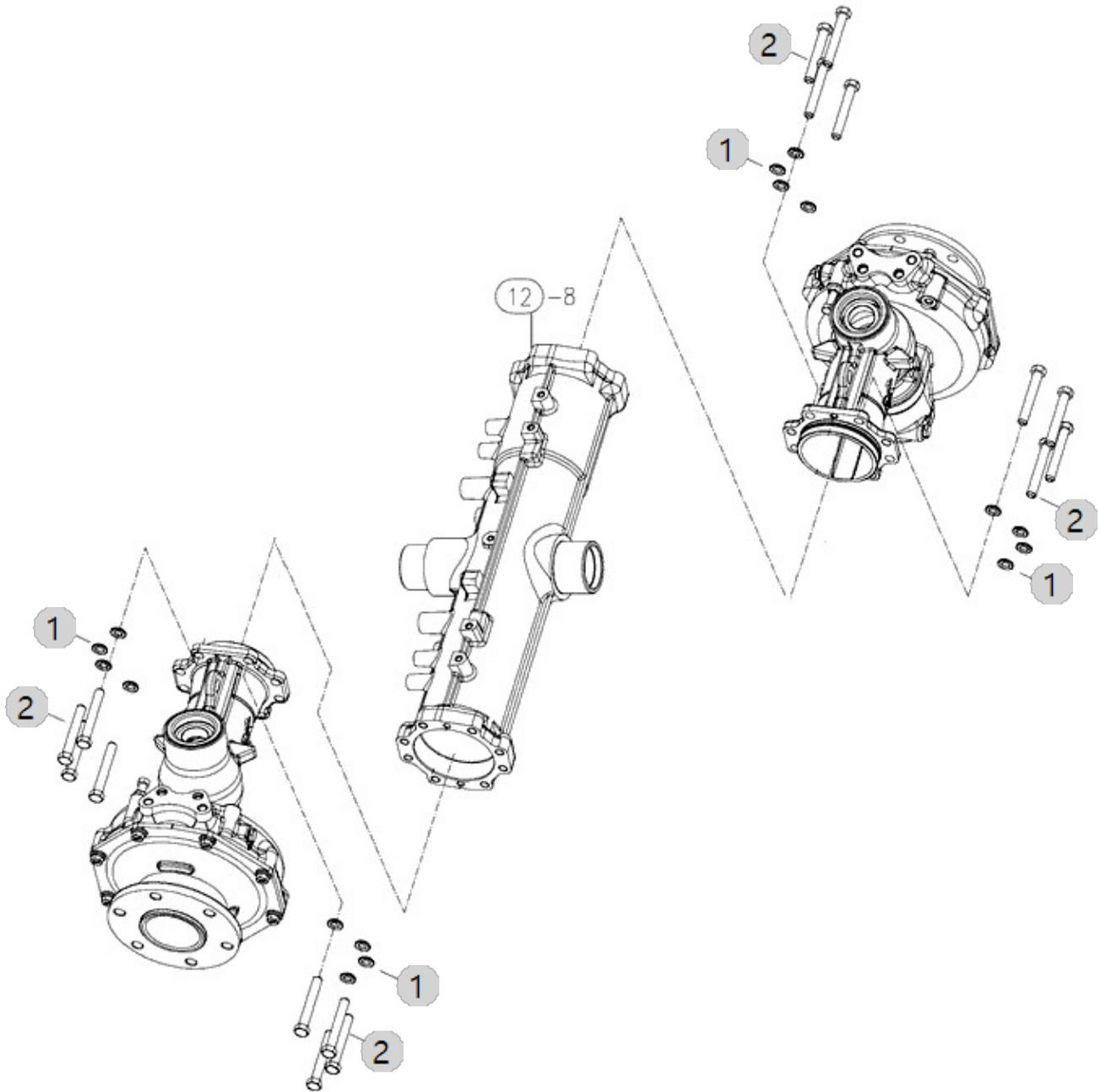

E01020

SHAFT COVER

Year/Month

6225C(EU)(AC02123)

2022-12-19

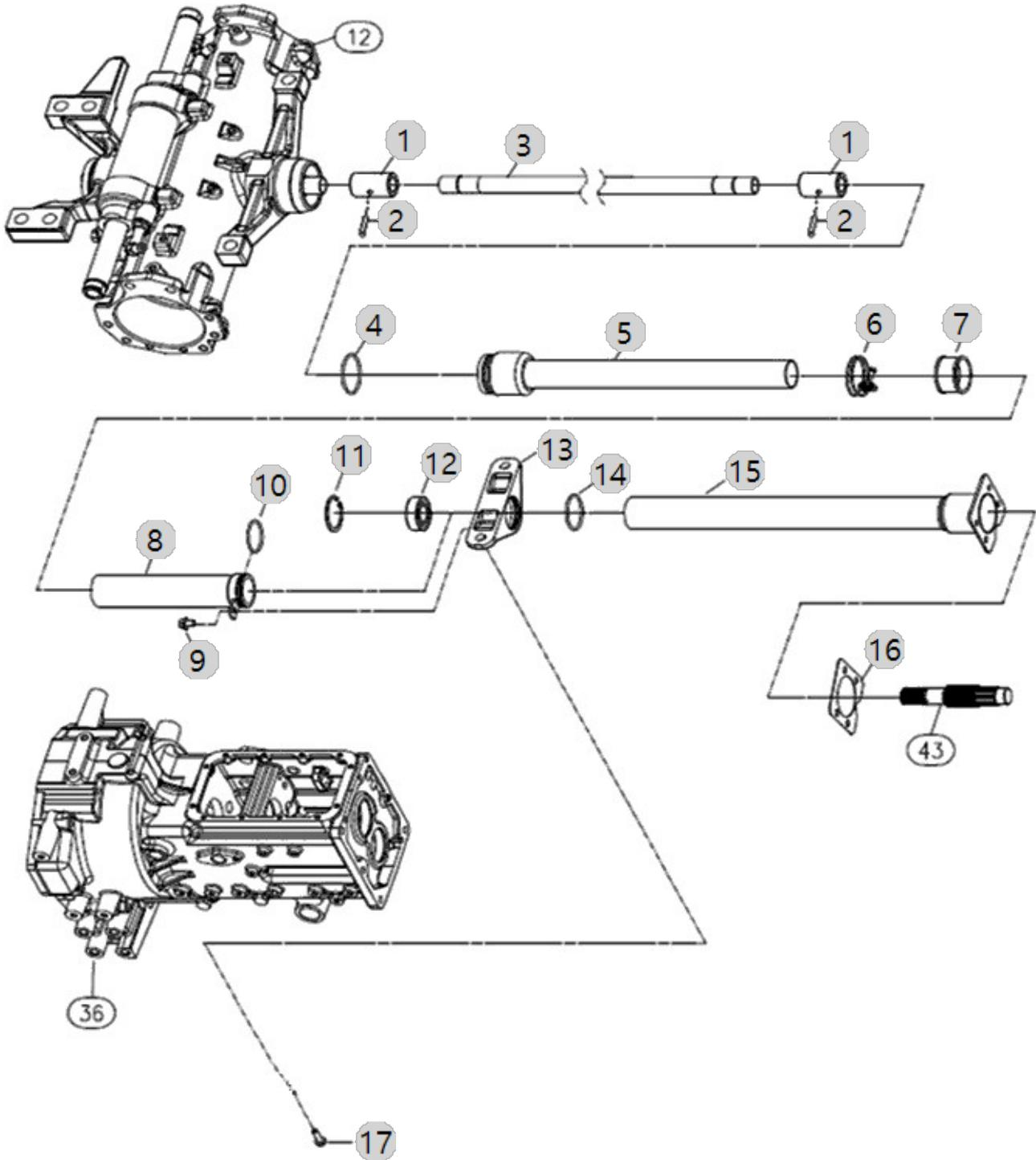

E01020 6225C(EU)(AC02123)		SHAFT COVER				Year/Month
						2022-12-19
순번 (NO)	부품번호 (PART NO)	품명 (PART NAME)	품명 (PART NAME)	수량 (QTY)	규격 (SPEC)	비고 (REMARK)
1	NT15080000B4	커플링 R	COUPLING(R)	2	D35	
2	22351-040036	스프링핀	SPRING PIN	2	D4X36	
3	TA00015872C	프로펠라축	SHAFT	1	D25	
4	24321-000550	O-링	SEAL,O-RING	1	1A G55.0	
5	TC62110100B3	축커버(전)	SHAFT COVER, FRONT	1	NONE	
5	TC62110100A3	축커버(전)	COVER SHAFT (FRONT)	1		
6	23010-055000	클램프	HOSEBAND55	1	D55	
7	TC62020000A4	부츠(축커버)	BOOTS,SHAFT COVER	1		
8	TA00031873A	축 커버 (전) 후 조합	COVER SHAFT (FRONT) REAR	1	-	
8	TA00031873B	축 커버 (전) 후 조합	COVER SHAFT (FRONT) REAR ASS'Y	1	-	
9	26106-080122	육각플랜지볼트	Bolt, Hexa (8-12)	1	M8XP1.25X12	
10	24321-000450	O링(G형)	O-RING, DYNAMIC (Φ45)	1	G45	
11	22252-000520	CIRCLIP52	RING, CIRCLIP (Φ 52)	1	D52(구멍용)	
12	24104-062054	볼베어링6205UU	BALL BEARING (#6205UU)	1	#6205UU	
13	TA00042166C	베어링 홀더	BEARING HOLDER	1		
13	TA00042166B	베어링 홀더	BEARING HOLDER	1		
14	24321-000500	O링(G형)	O-RING (D50)	1	G50	
15	TA00031871C	축 커버(후) 20	COVER SHAFT (REAR)	1	-	
15	TA00031871B	축 커버(후) 20	COVER SHAFT (REAR)	1	-	
16	TN23070000B4	축 커버 패킹	SHAFT, PACKING COVER	1	0.5T	
17	26106-120252	육각플랜지볼트	HEX FLANGE BOLT	2		

E01030

6225C(EU)(AC02123)

GEAR CASE, FRONT AXLE

Year/Month

2022-12-19

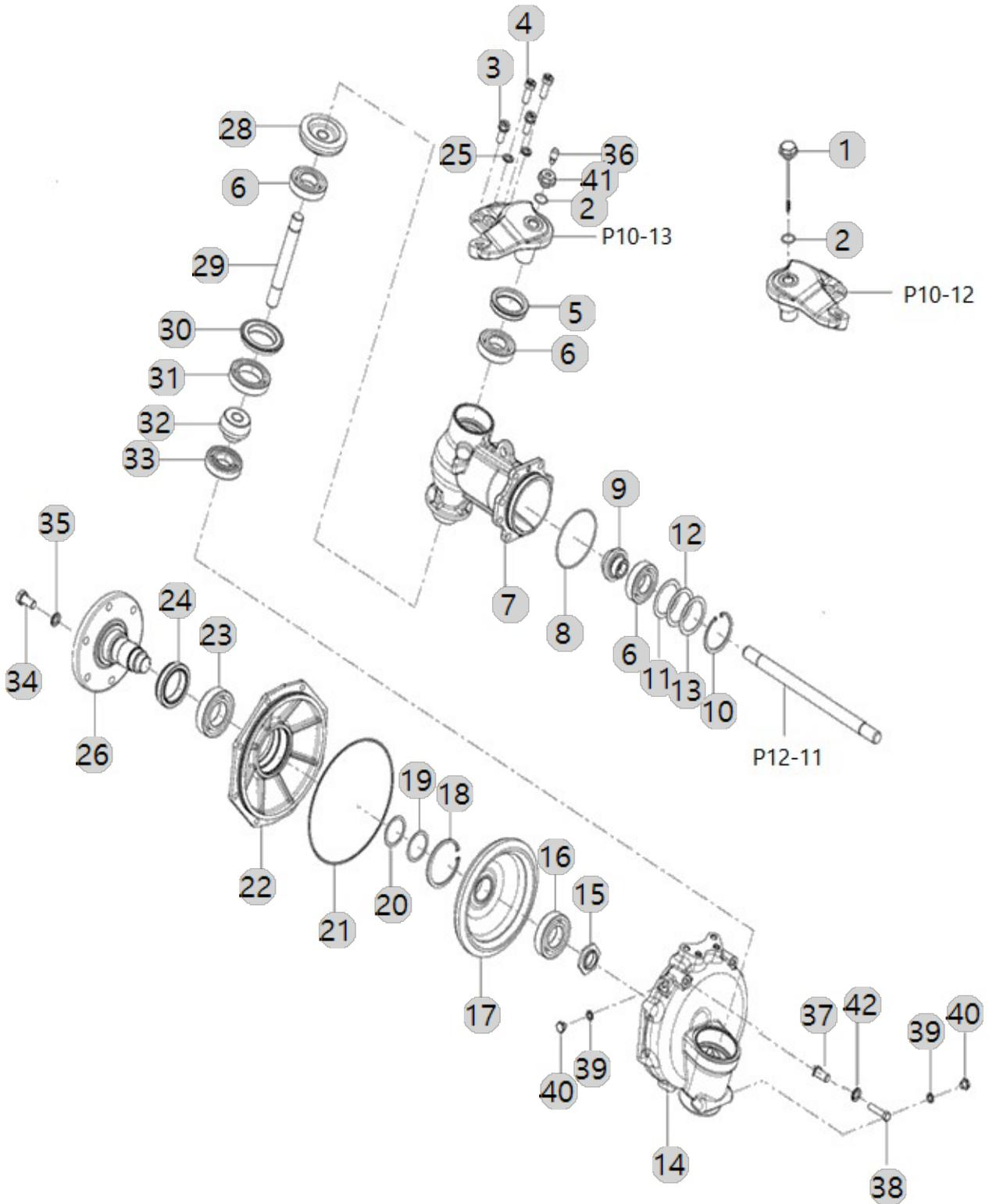

E01030		GEAR CASE, FRONT AXLE				Year/Month
6225C(EU)(AC02123)						2022-12-19
순번 (NO)	부품번호 (PART NO)	품명 (PART NAME)	품명 (PART NAME)	수량 (QTY)	규격 (SPEC)	비고 (REMARK)
1	TA00033805A	검유봉	OIL GUAGE	1		
2	24311-000220	O-RING1AP-22.0	O-RING, DYNAMIC (Φ22)	2	1A P22.0	
3	TA00033468C	와셔조립육각볼트	BOLT W/ WASHER	4		
4	TA00033475B	리머볼트	SPACER	4		
5	FE78010000B	오일실 (특수) 55x72x13.5	OIL SEAL (55X72X13.5)	2	55X72X13.5	
6	24101-062074	볼베어링6207	BALL BEARING (#6207)	6	#6207	
7	TA00048728A	프런트기어케이스(20)	CASE, FRONT GEAR	2		
8	24321-001050	O-링	O-RING	2		
9	TA00033461B	전1축피니언9T	PINION, FRONT 1ST SHAFT	2		
10	22252-000720	구멍용스냅링72	RING, CIRCLIP (Φ 72)	2	D72	
11	TA00033489A	심 0.2T	SHIM 0.2T	2		
12	TA00033488A	심 0.3T	SHIM 0.3T	2		
13	TA00033487A	심 0.5T	SHIM 0.5T	2		
14	TA00033458C	프런트기어박스	GEAR BOX, FRONT	2		
15	TA00033481A	로크너트	LOCK NUT	2		
16	24101-062084	볼베어링6208	Bearing, Ball (#6208)	2	#6208	
17	TA00033474A	베벨기어 49T	GEAR, BEVEL 49T	2		
18	22252-000850	써클립85H	RING, CIRCLIP (Φ 85)	2		
19	TA00033486A	심 0.2T	SHIM 0.2T	1		
20	TA00033485A	심 0.5T	SHIM 0.5T	1		
21	TA00033939A	O링	O RING	2		
22	TA00033459C	프런트베어링케이스	BEARING CASE, FRONT	1		
23	24101-062094	볼베어링6209	BALL BEARING (#6209)	2	#6209	
24	TA00041359A	오일실	OILSEAL	2		
25	22217-120000	스프링와셔	WASHER, SPRING (Φ 12)	2	M12	
26	TA00033460D	프런트스핀들	SPINDLE, FRONT	2		
26	TA00033460C	프런트스핀들	SPINDLE, FRONT	2		
26	TA00033460E	프런트스핀들	SPINDLE, FRONT	2		
27	TA00033469B	와셔조립육각볼트	BOLT W/ WASHER	16		
28	TA00033463A	전2축기어	FRONT 2ND AXLE LH	2		
29	TA00033464A	전2축	FRONT 2ND SHAFT	2		
30	TC60110000A3	오일실(AJ)	SEAL, OIL	2		
31	24101-060104	볼베어링6010	Bearing, Ball (#6010)	2	#6010	
32	TA00033473A	베벨기어 11T	GEAR, BEVEL 11T	2		
33	TC60340000A4	베어링TM207C3	BEARING(TM207C3)	2	TM207C3	
34	TD23120000B4	프런트 허브 볼트(M14X28)	BOLT	12	M14XP1.5	
35	22217-140000	스프링와셔14	WASHER, SPRING (Φ 14)	12	M14	
36	TA00049842A	에어브리더(STEEL)	AIR BREATHER	1		
36	TA00049842B	에어브리더(STEEL)	AIR BREATHER	1		
37	TA00058613A	스톱퍼(25.5)	STOPPER(25.5)	2		
38	26112-100502	SUB TO 26116-100502	SUB TO 26116-100502	2		
39	22190-100000	실와셔	WASHER	4	M10	
40	23887-100002	플러그(미터)	SCREW,HEXAGONHEADCAP	4	M10	
41	TA00049843B	에어브리더 플러그	ADAPThER	1		
42	22217-100000	스프링와셔	WASHER, SPRING (Φ 10)	2	M10	

E01070

FORNT DRIVE SHAFT

Year/Month

6225C(EU)(AC02123)

2022-12-19

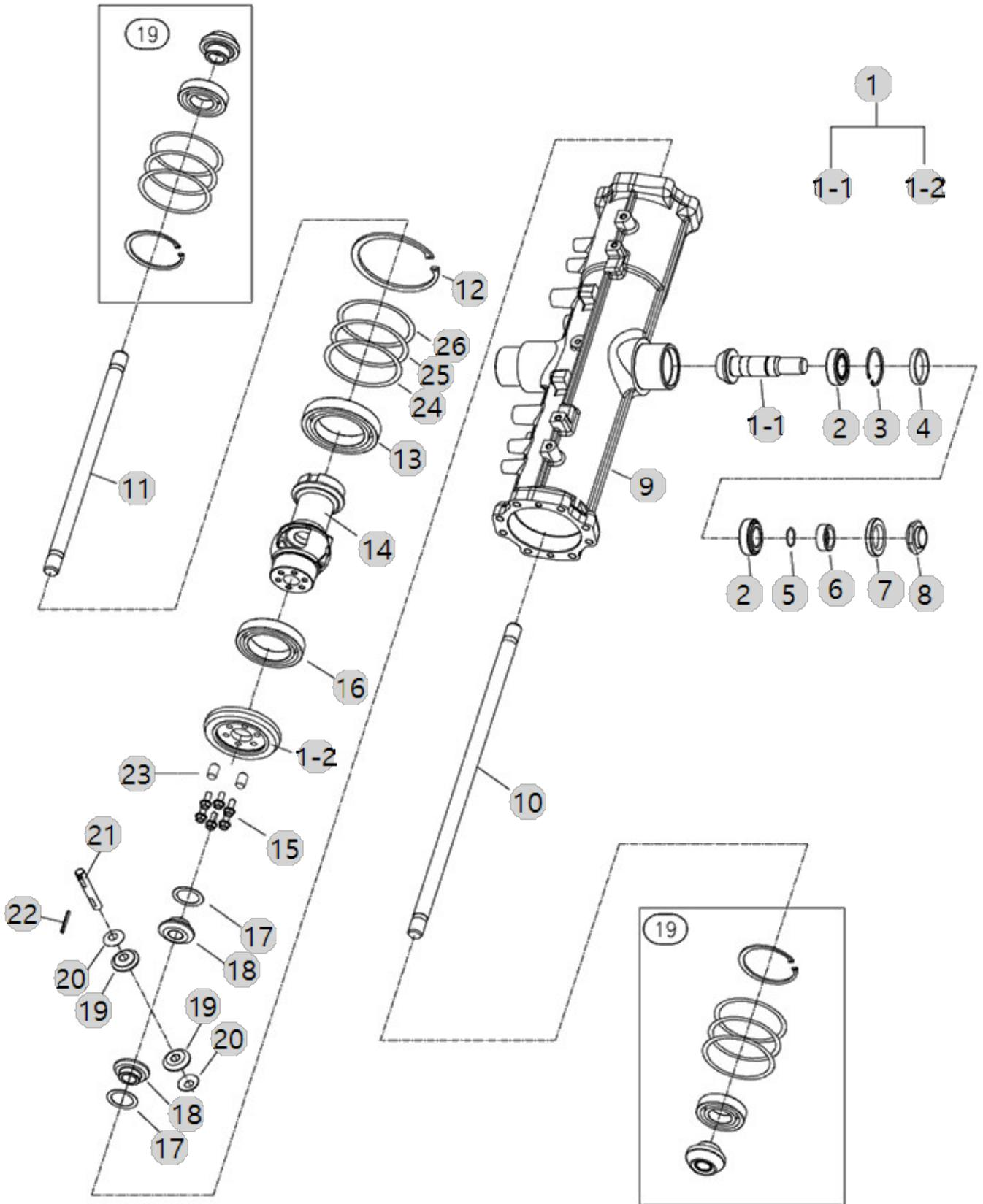

E01070		FORNT DRIVE SHAFT				Year/Month
6225C(EU)(AC02123)						2022-12-19
순번 (NO)	부품번호 (PART NO)	품 명 (PART NAME)	품 명 (PART NAME)	수량 (QTY)	규격 (SPEC)	비고 (REMARK)
1	TA00033454C	링기어조합	RING GEAR ASSY	1		
1-1	TA00033455B	카운터축	COUNT SHAFT	1		
1-2	TA00033456C	링기어	RING GEAR	1		
2	24141-320060	테이퍼롤러베어링320060	BEARING, ROLLER (#32-00-60)	2	32006	
3	22252-000550	구멍용스냅링(C형)	RING, CIRCLIP (Φ 55)	1	D55	
4	TA00033478A	간격판	PLATE	1		
5	24311-000300	O링(P형)	O RING(P TYPE)	1	P30	
6	TA00033471A	부시	BUSH	1		
7	24421-405508	오일실TC405508	OIL SEAL	1		
8	TA00033472A	너트	NUT	1		
9	TA00033449A	전차축케이스	CASE, FRONT AXLE	1		
10	TA00033827A	전1축LH_20h	1ST SHAFT	1		
11	TA00033828A	전1축RH_20h	1ST SHAFT	1		
12	22252-001100	구멍용스냅링	RING, CIRCLIP (Φ110)	2	D110	
13	24101-060144	볼베어링6014	BALL BEARING (#6014)	1	#6014	
14	TA00033451C	차동케이스	DIFF. CASE	1		
15	TA00054318B	볼트(M8X1.0)	BOLT	6		
16	24101-060134	볼베어링6013	BALL BEARING (#6013)	2		
17	TC57120000A4	차동사이드기어라이너	LINER, DIFFERENTIAL GEAR	2		
18	TC57090000A4	차동사이드기어14	GEAR, DIFFERENTIAL 14	2		
19	TC57100000A4	차동피니언기어10	DIFFERENTIAL PINION GEAR 10	2		
20	TC57130000A4	차동피니언라이너	LINER, DIFFERENTIAL PINION	2		
21	TC57110000B4	차동피니언축	SHAFT, PINION	1		
22	22351-040040	스프링핀	PIN, SPRING (4-04)	1	D4X40	
23	22312-080140	평행핀	PIN, DOWEL (8-14)	2	D8X14	
24	TA00033482A	심 0.5T	SHIM 0.5T	1		
25	TA00033483A	심 0.3T	SHIM 0.3T	1		
26	TA00033484A	심 0.2T	SHIM 0.2T	1		

E01080
6225C(EU)(AC02123)

TIE ROD

Year/Month
2022-12-19

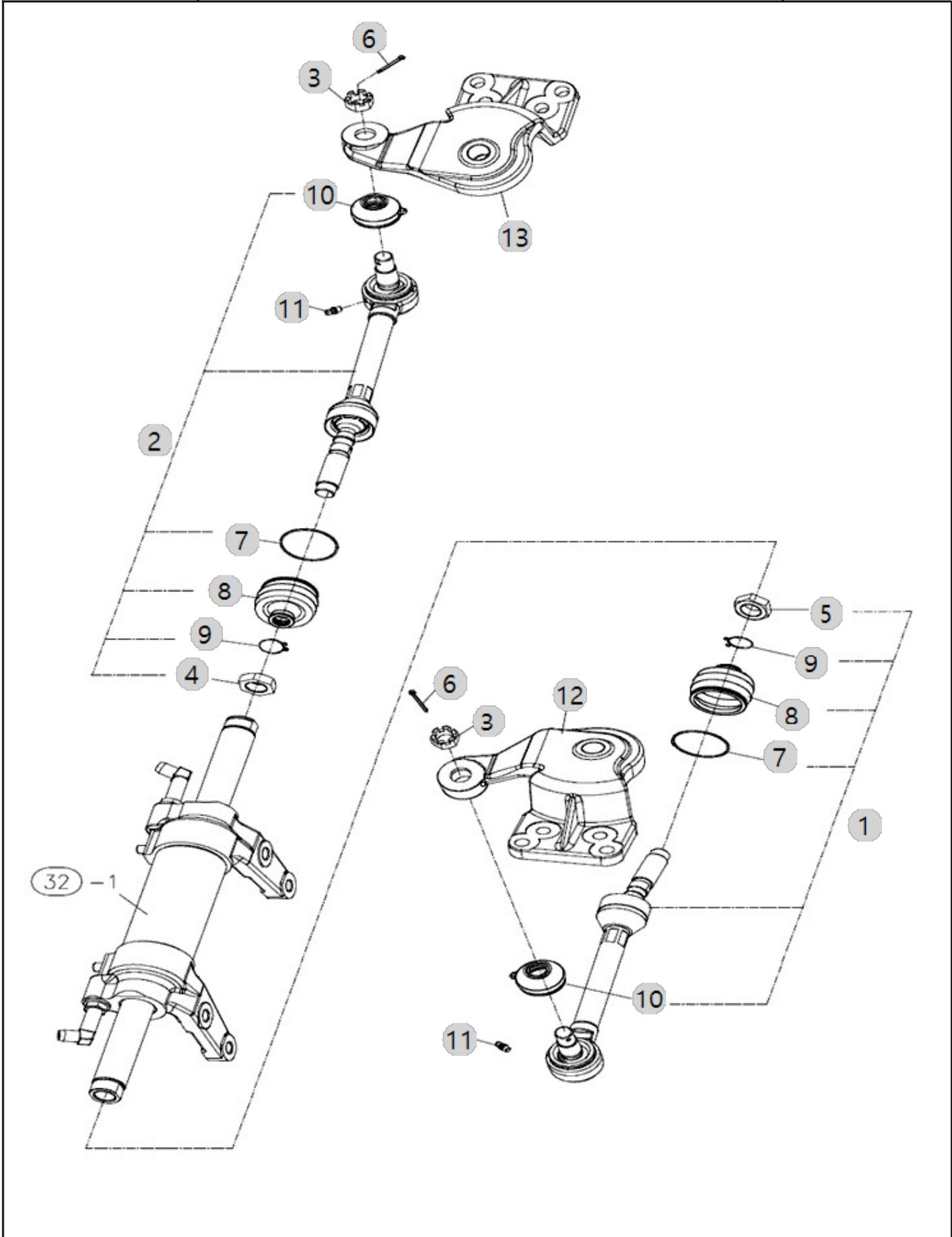

F01010

25CABIN TM총조합
(NEC)(AC01457)

CLUTCH HOUSING

Year/Month

2022-12-19

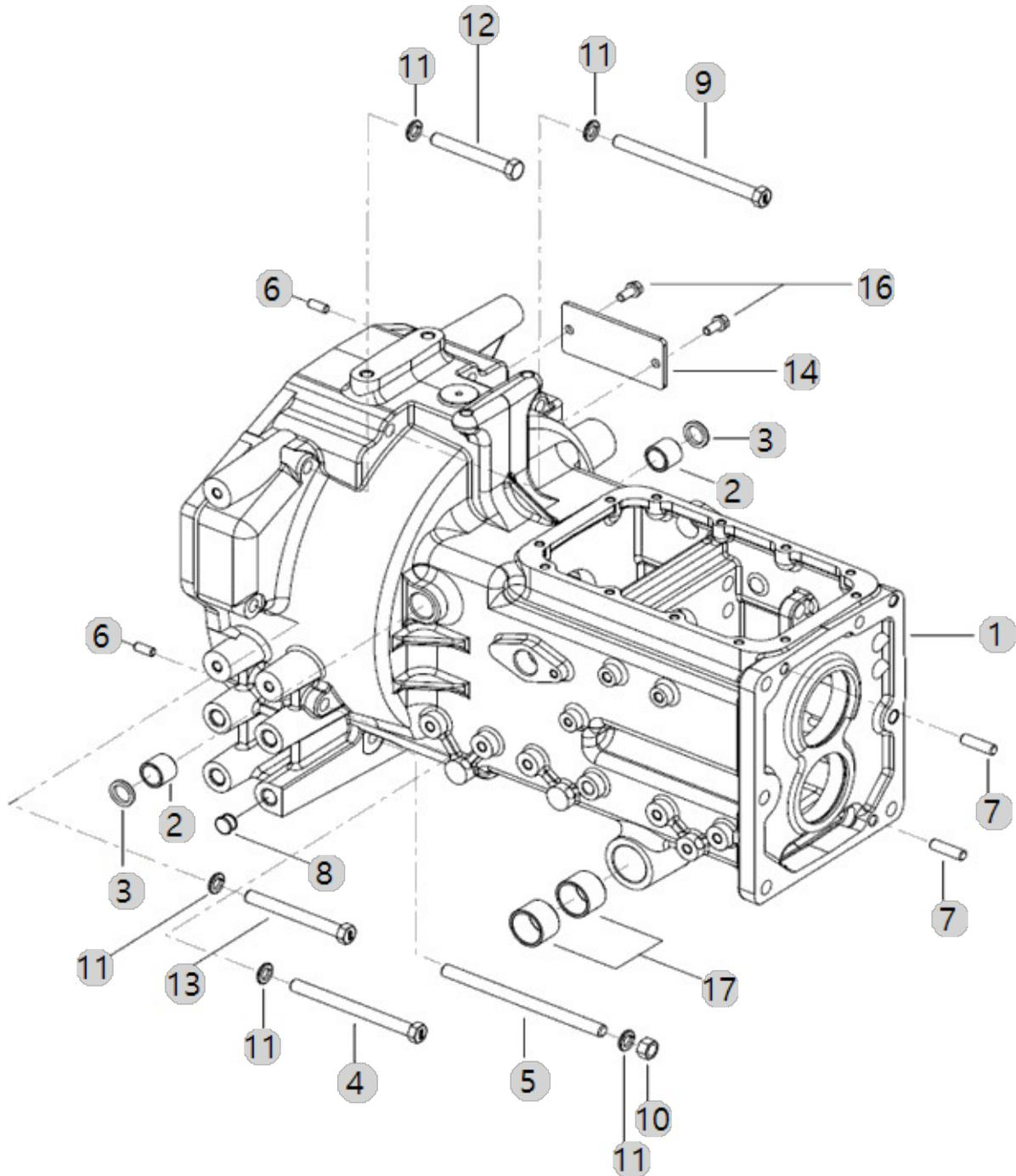

F01020

25CABIN TM총조합
(NEC)(AC01457)

TRANSMISSION CASE

Year/Month

2022-12-19

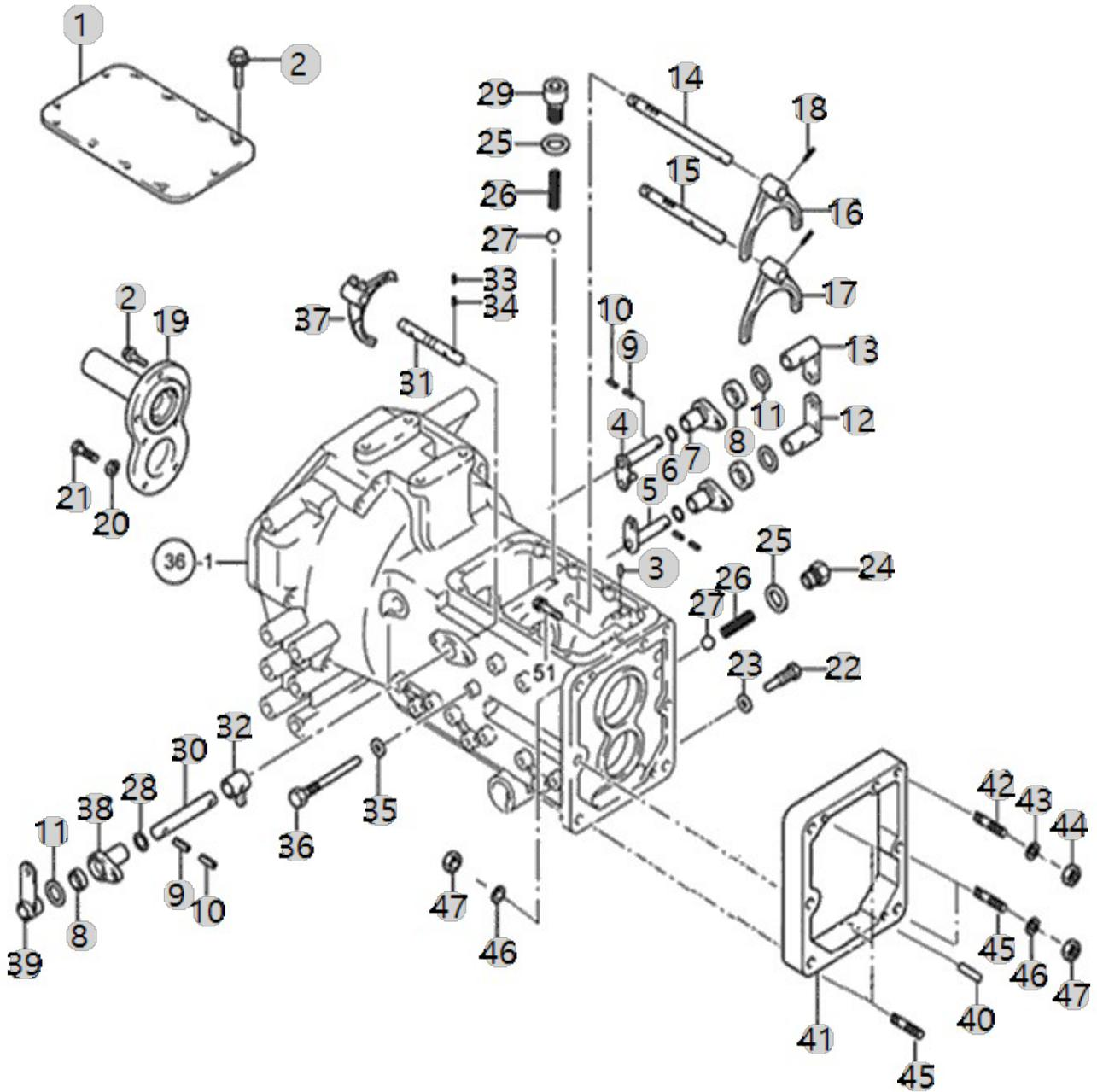

F01020 25CABIN TM총조합 (NEC)(AC01457)		TRANSMISSION CASE				Year/Month 2022-12-19
순번 (NO)	부품번호 (PART NO)	품명 (PART NAME)	품명 (PART NAME)	수량 (QTY)	규격 (SPEC)	비고 (REMARK)
1	NT41010000C3	미션상커버	UPPERCOVER,T/M	1	9.0T	
2	26013-080252	와셔조립육각볼트(+SW)	Bolt, Hexa (8-25)	19	M8XP1.25X25	
3	TN41070000A4	더블기어방지핀	PIN	1		
4	NT41080000A4	주변속시프터레버(3-4)	LEVER3-4	1		
4	NT41080000B4	주변속시프터레버(3-4)	MAIN SHIFTER LEVER-4	1		
5	NT41600000A4	주변속시프터레버(1-2)	LEVER[1ST-2ND],MAINSHIFT	1		
5	NT41600000B4	주변속시프터레버(1-2)	LEVER(1ST-2ND),MAIN SHIFT	1		
6	24311-000210	361,A22,O-RING1AP-21.0	O-RING, DYNAMIC (Φ21)	3	P21	
7	TN41100000A4	주변속시프터홀더	HOLDERMAINSHIFT	2		
8	24421-173007	오일실TC173007	Seal, Oil (#17-30-07)	3	TC17X30X7	
9	22351-080028	스프링핀8X28	PIN, SPRING (8-28)	2	D8X28	
10	22351-050028	스프링핀5X28	PIN, SPRING (5-02)	2	D5X28	DEL.20221012
11	TT65120000A4	칼라B	COLLARB	3	T2.3X45X45	
12	NT41130000B4	주변속아암3-4단	ARM(3-4), MAIN SHIFT	1		
12	NT41130000C4	주변속아암3-4단	ARM(3-4), MAIN SHIFT	1		
13	NT41140000A4	주변속아암(1-2)	ARM(1-2),MAINSHIFT	1		
13	NT41140000B4	주변속아암(1-2)	ARM(1-2),MAINSHIFT	1		
14	NT41150000A3	주변속3-4단포크축	FORKSHAFT[3-4],MAINSHIFT	1	D15	
15	NT41160000A3	주변속1-2단포크축	FORKSHAFT(1-2),MAINSHIFT	1	D15	
16	TN41170000D3	주변속포오크(1-2)	FORK1ST~2ND,MAINSHIFT	1		
17	TN41180000D3	주변속포오크(3-4)	FORK3-4MAINSHAFT	1		
18	22351-060030	스프링핀	PIN, SPRING (6-30)	2		
19	NT41580000C2	주축오일실케이스_4기통	OIL SEAL CASE	1		
20	22217-080000	스프링와셔8	WASHER, SPRING (Φ 08)	5	M8	
21	26116-080222	볼트7T(8X22)	BOLT7T(8X22)	5	M8X1.25X22	
22	TN41250000B4	단붙이고정볼트	FIXINGBOLT	1		
23	23414-100000	429,A202322,패킹10	PLAIN WASHER (D10)	1	M10	
24	NT41270000B4	캡 볼트	CAPBOLT	1		
25	23414-160000	동패킹	WASHER,SEALING	2	M16	
26	TT42020000A4	스프링	SPRING	3		
27	24190-100001	강구5/16	Ball, Steel (5/16)	3	5/16"	
28	24311-000110	O-링 495-11	O-RING, DYNAMIC (Φ11)	1	P11	
29	23871-010000	테이퍼플러그	PLUG	1	PT1/8	
30	NT41350000A4	축(셔틀체인지)	SHAFT, SHUTTLE CHANGE	1		
30	NT41350000B4	축(셔틀체인지)	SHAFTSHUTTLECHANGE	1	D17	
31	TN41360000A3	셔틀시프터포오크축	SHAFTSH.FORK	1	D15X127	
32	NT41380000A4	셔틀샤프트레버	LEVERSHUTTLESHAFT	1		
32	NT41380000B4	셔틀시프터레버	LEVER SHUTTLE SHAFT	1		
33	22351-060025	SPRINGPIN6X25	PIN, SPRING (6-25)	2	D6X25	
34	22351-080028	스프링핀8X28	PIN, SPRING (8-28)	1	D8X28	
35	23414-080000	320,ALL,패킹8	WASHER, PLAIN (Φ8)	1	M8	
36	NT41460000A4	단붙이볼트	BOLT	1		
37	TN41490000C3	셔틀포오크	FORK,SHUTTLE	1		
38	NT41540000A4	셔틀시프터홀더	HOLDER,SHUTTLESHIFT	1		
39	NT41550000D4	셔틀링크C	LINKC,SHUTTLE	1		

F01030

25CABIN TM총조합
(NEC)(AC01457)

HOUSING, REAR AXLE

Year/Month

2022-12-19

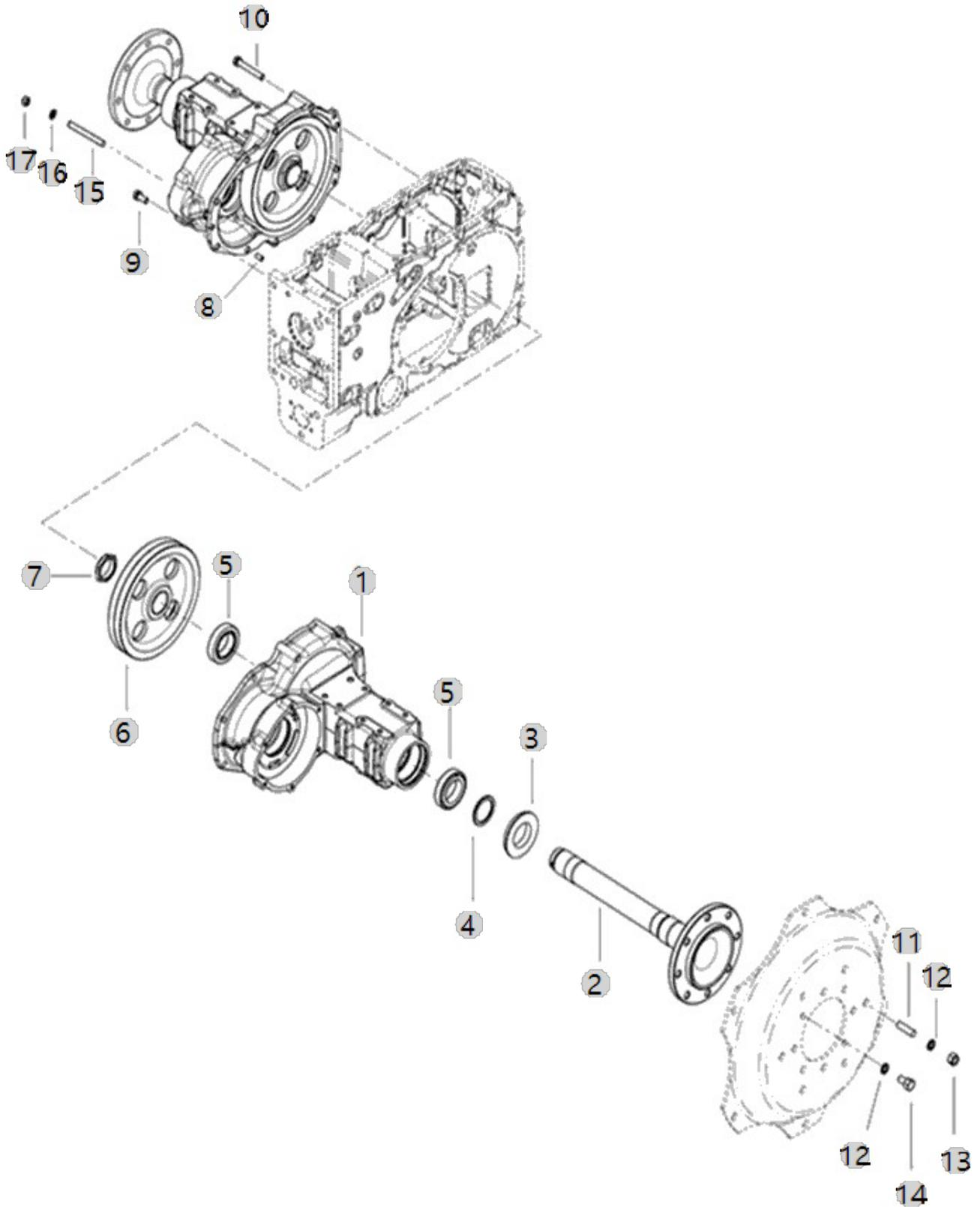

F02010

25CABIN TM총조합
(NEC)(AC01457)

CLUTCH RELEASE

Year/Month

2022-12-19

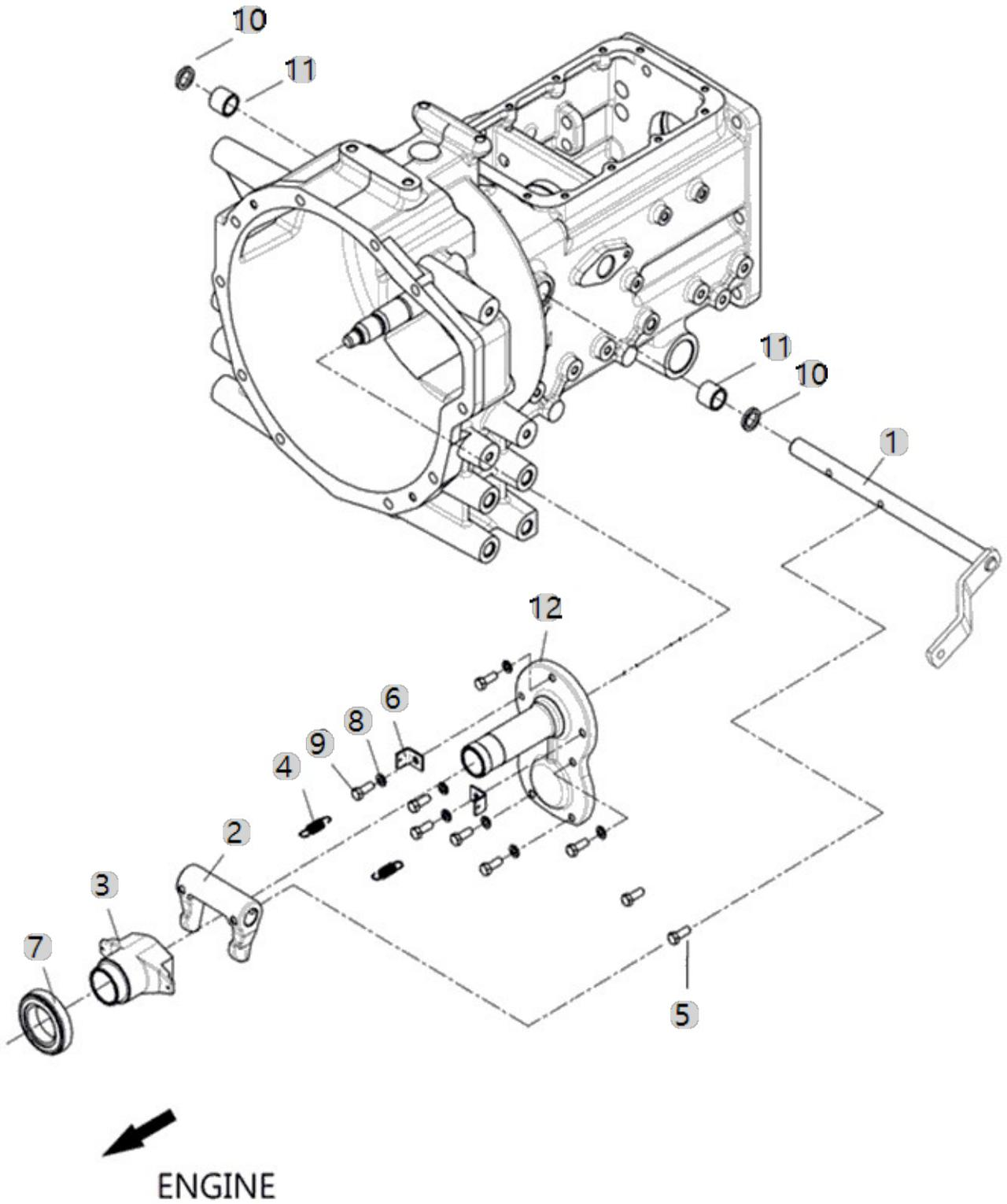

F02020

25CABIN TM총조합
(NEC)(AC01457)

CLUTCH SHAFT

Year/Month

2022-12-19

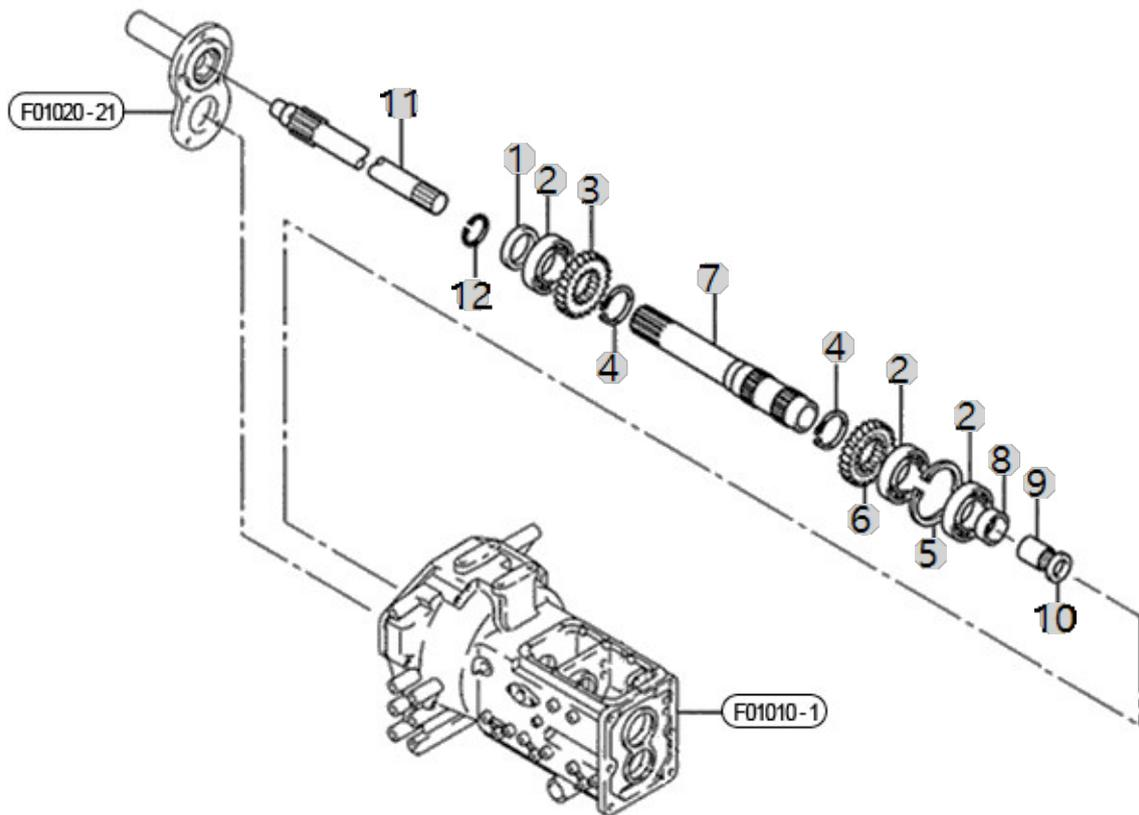

F02060

25CABIN TM총조합
(NEC)(AC01457)

REVERSE IDLE SHAFT

Year/Month

2022-12-19

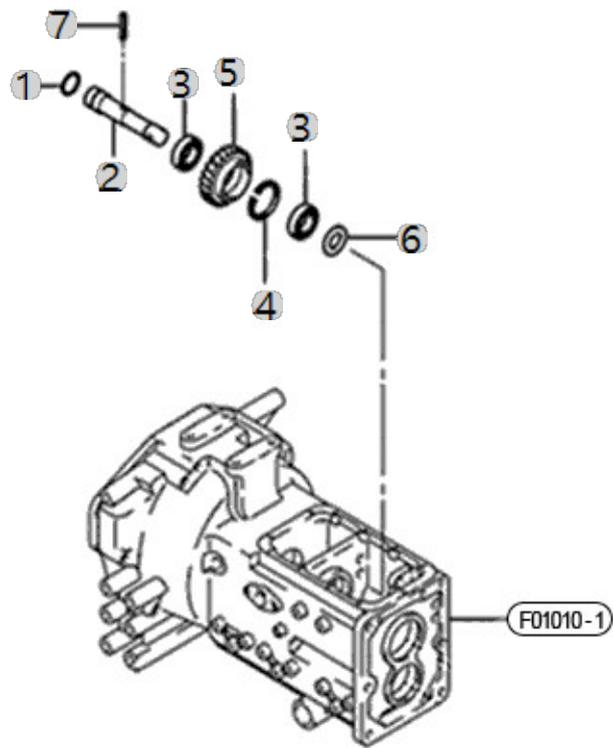

F02080

25CABIN TM총조합
(NEC)(AC01457)

CLUTH DISC

Year/Month

2022-12-19

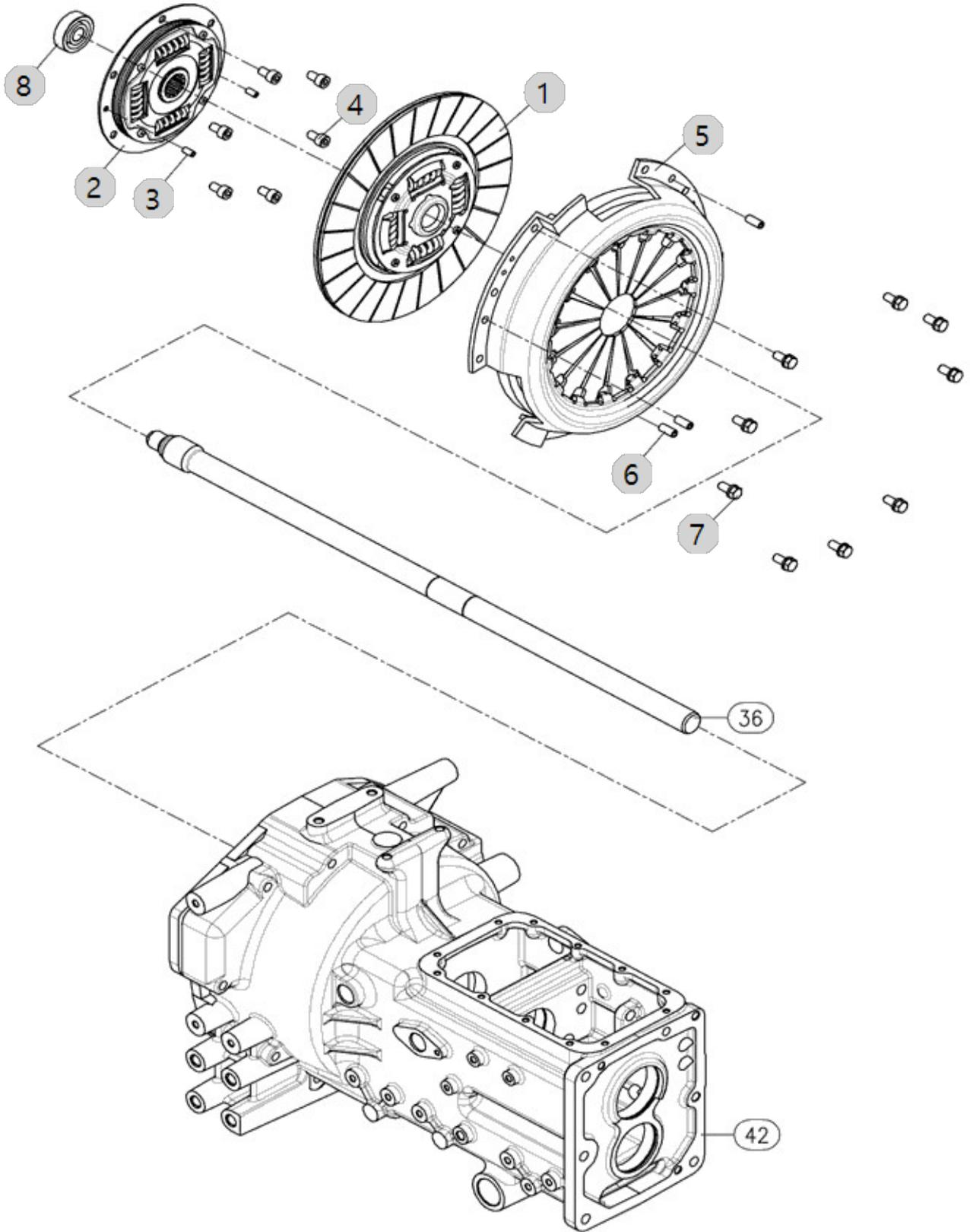

F03040

25CABIN TM총조합
(NEC)(AC01457)

RANGE SHIFT DRIVE SHAFT

Year/Month

2022-12-19

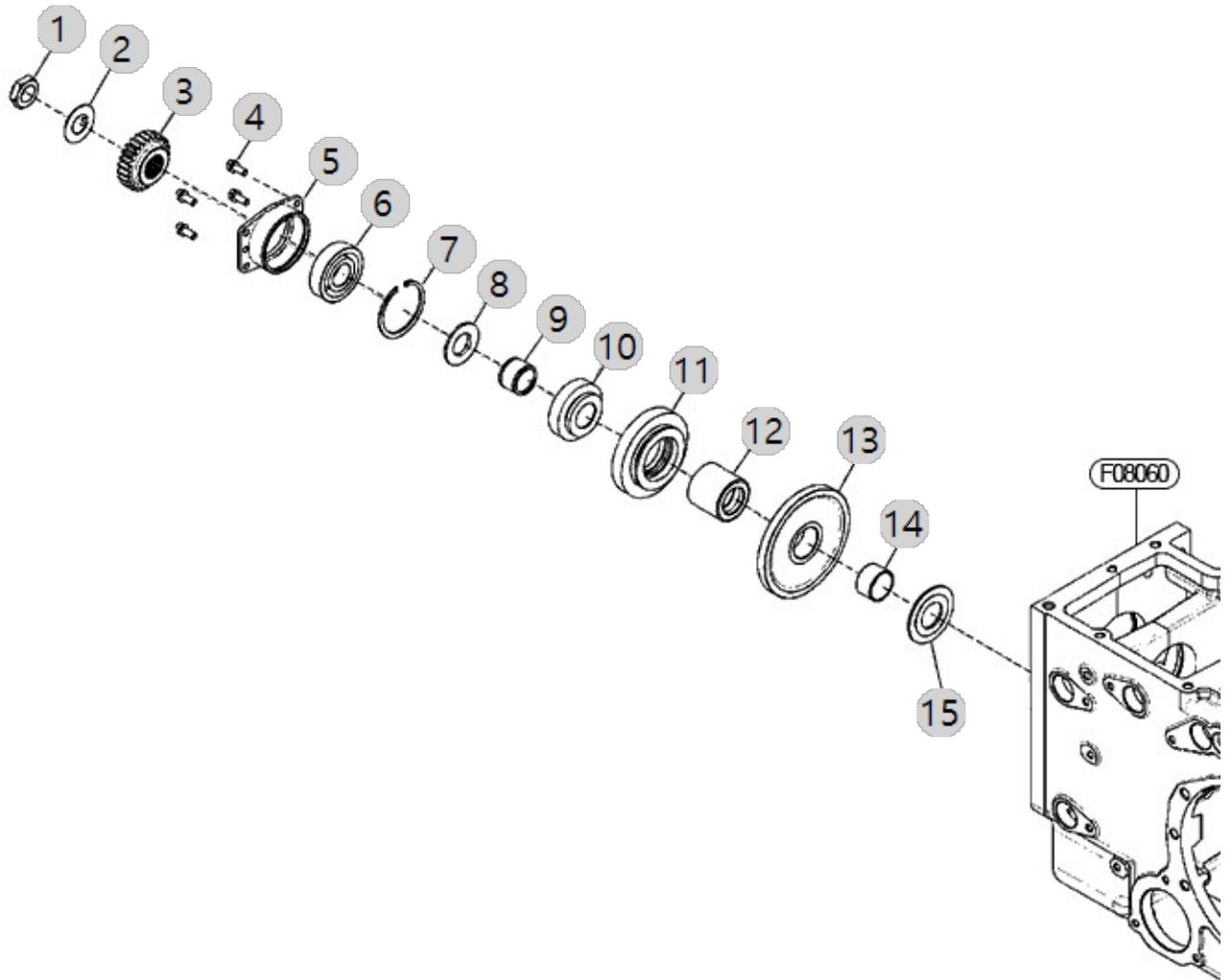

F03050

25CABIN TM총조합
(NEC)(AC01457)

RANGE SHIFT DRIVEN SHAFT

Year/Month

2022-12-19

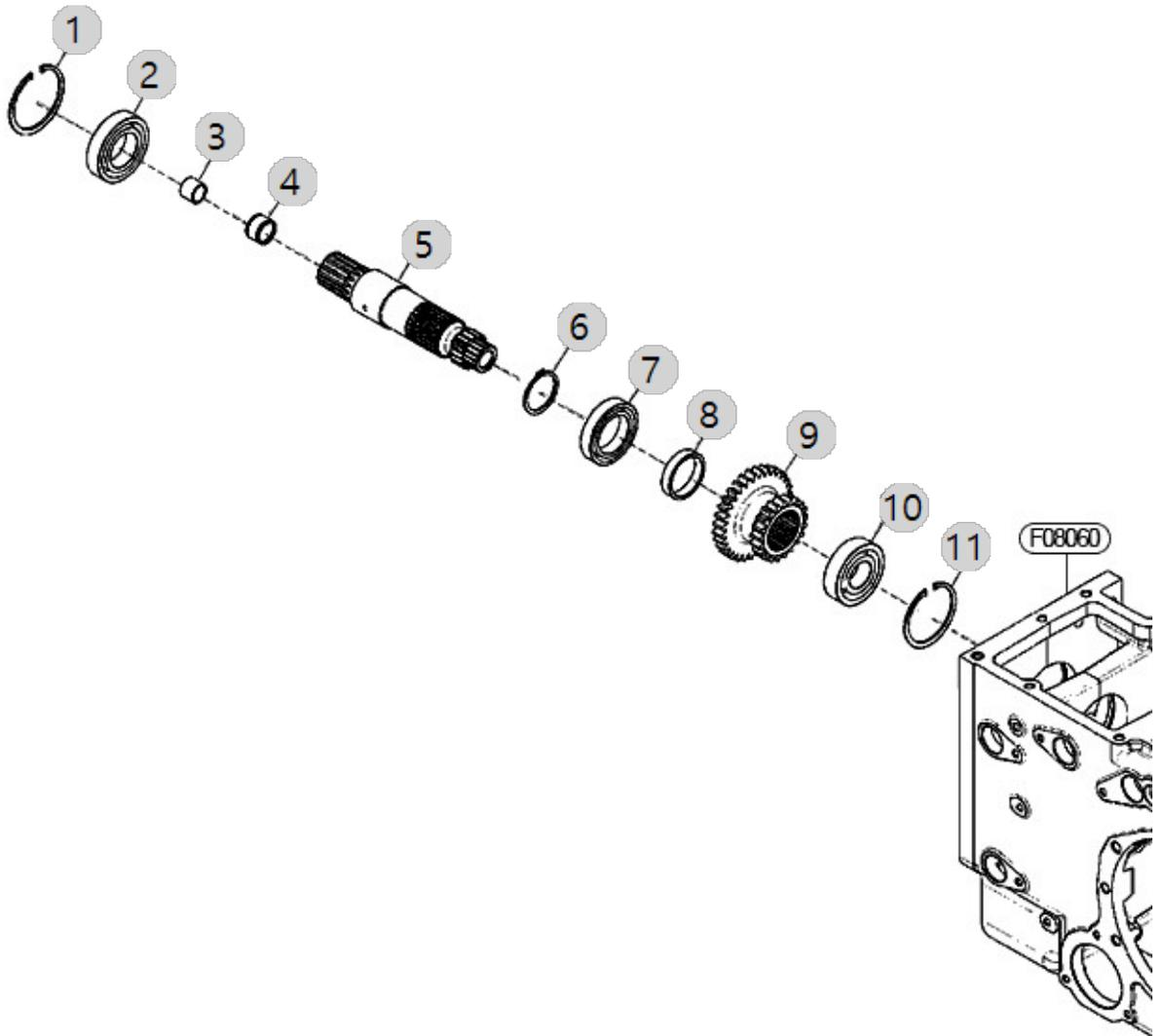

F03060

25CABIN TM총조합
(NEC)(AC01457)

COUNTER SHAFT

Year/Month

2022-12-19

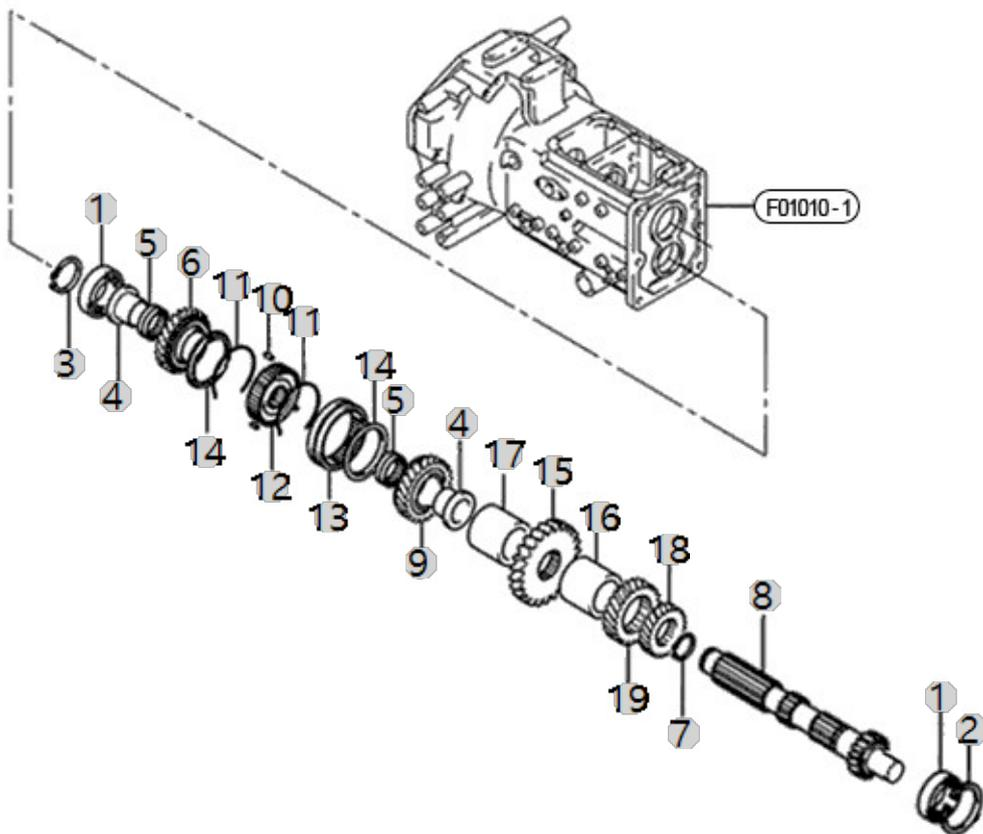

F03080

25CABIN TM총조합
(NEC)(AC01457)

GUIDE SHAFT, MAIN SHIFT

Year/Month

2022-12-19

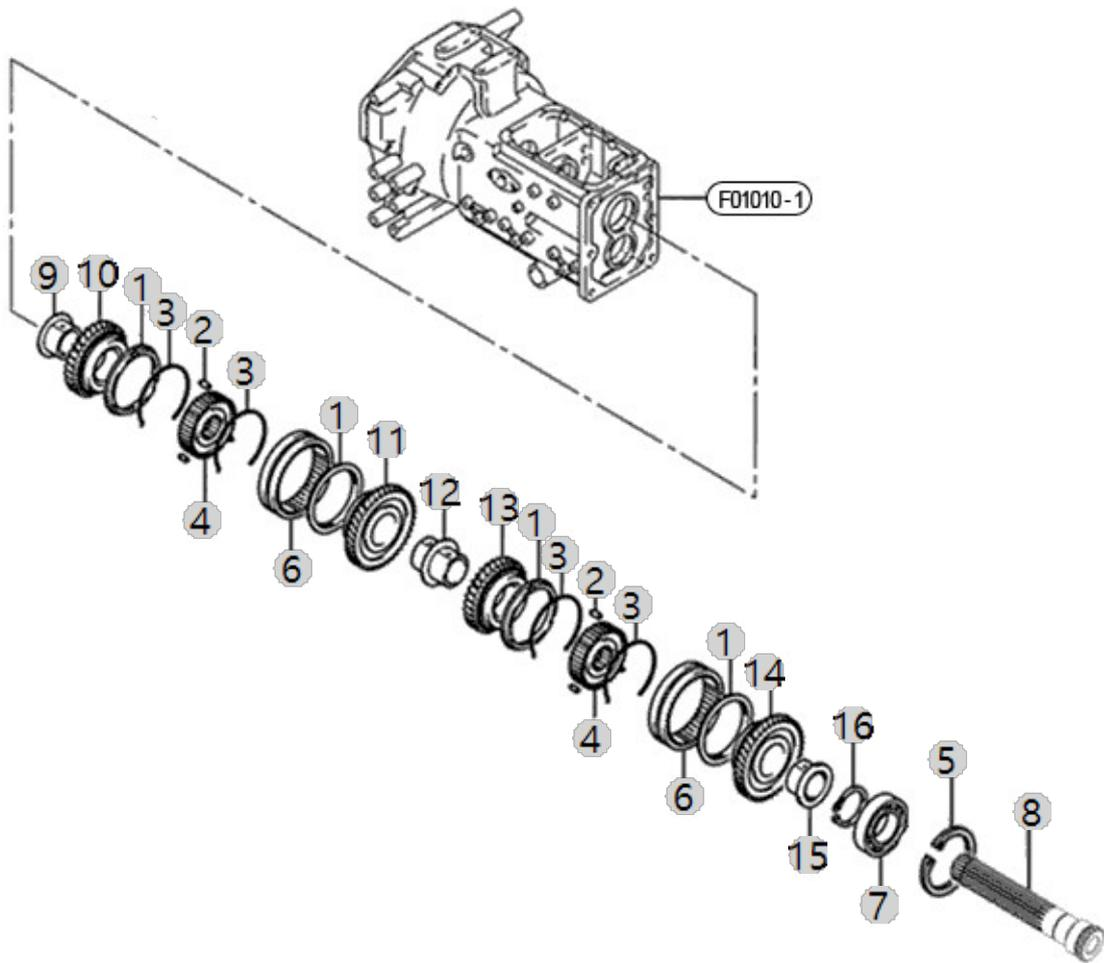

F04010

25CABIN TM총조합
(NEC)(AC01457)

FRONT WHEEL DRIVE SHAFT

Year/Month

2022-12-19

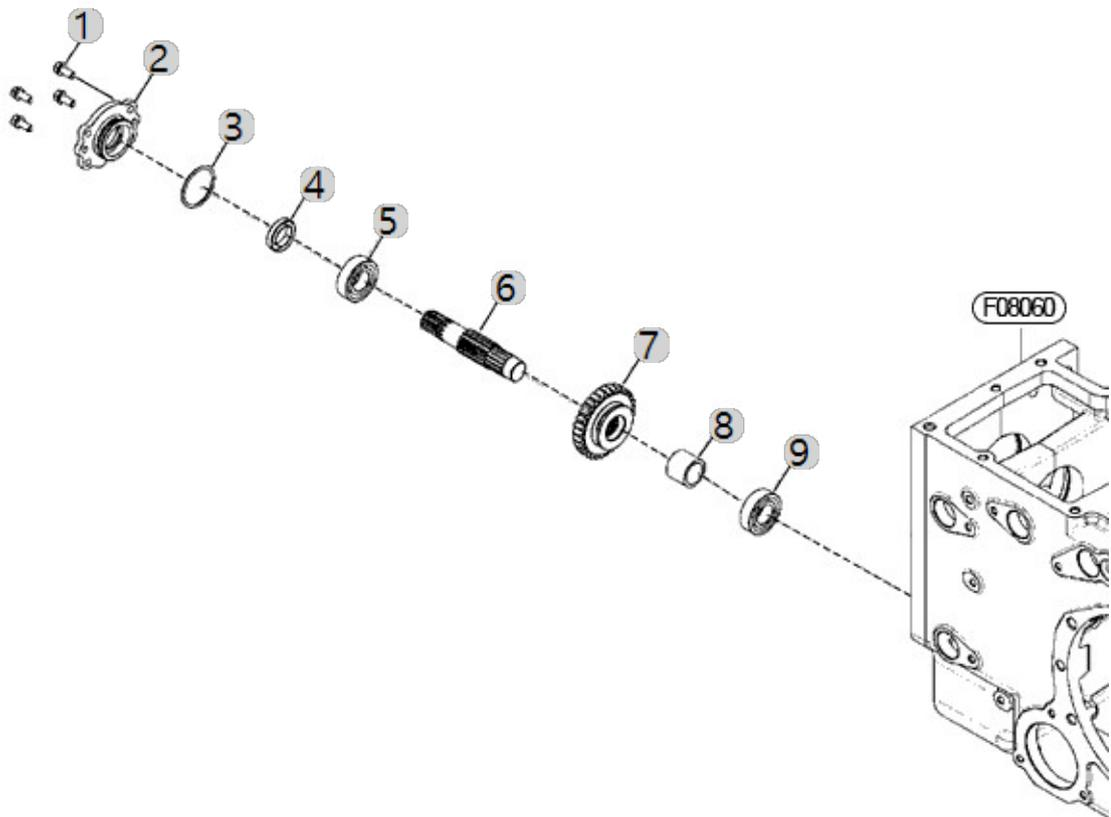

F04030

25CABIN TM총조합
(NEC)(AC01457)

FRONT WHEEL DRIVE IDLE SHAFT

Year/Month

2022-12-19

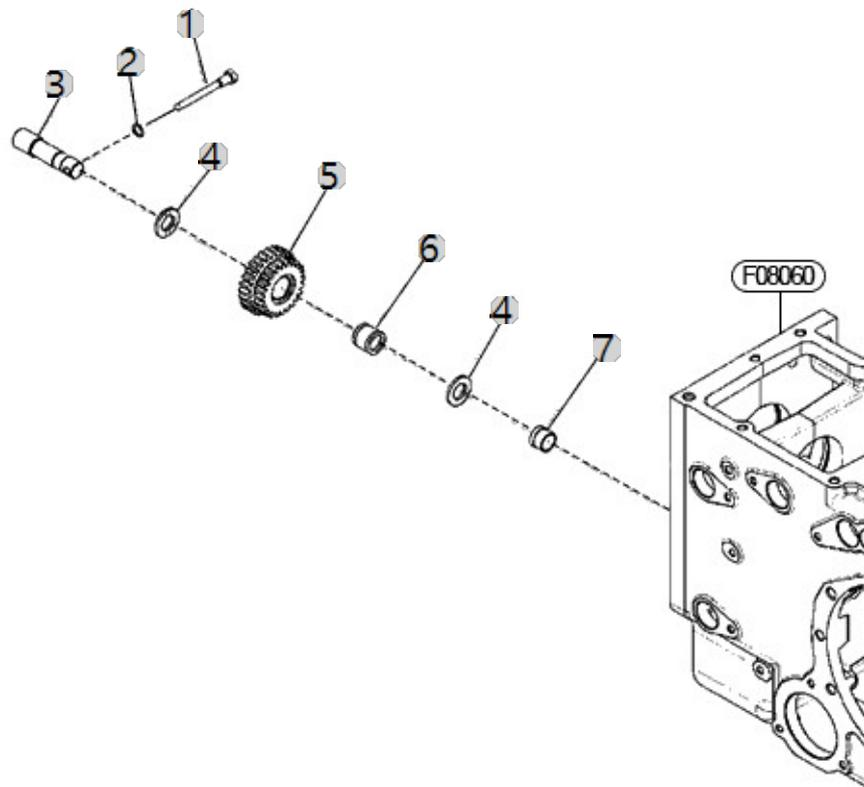

F05000

25CABIN TM총조합
(NEC)(AC01457)

DIFFERENTIAL ASS'Y

Year/Month

2022-12-19

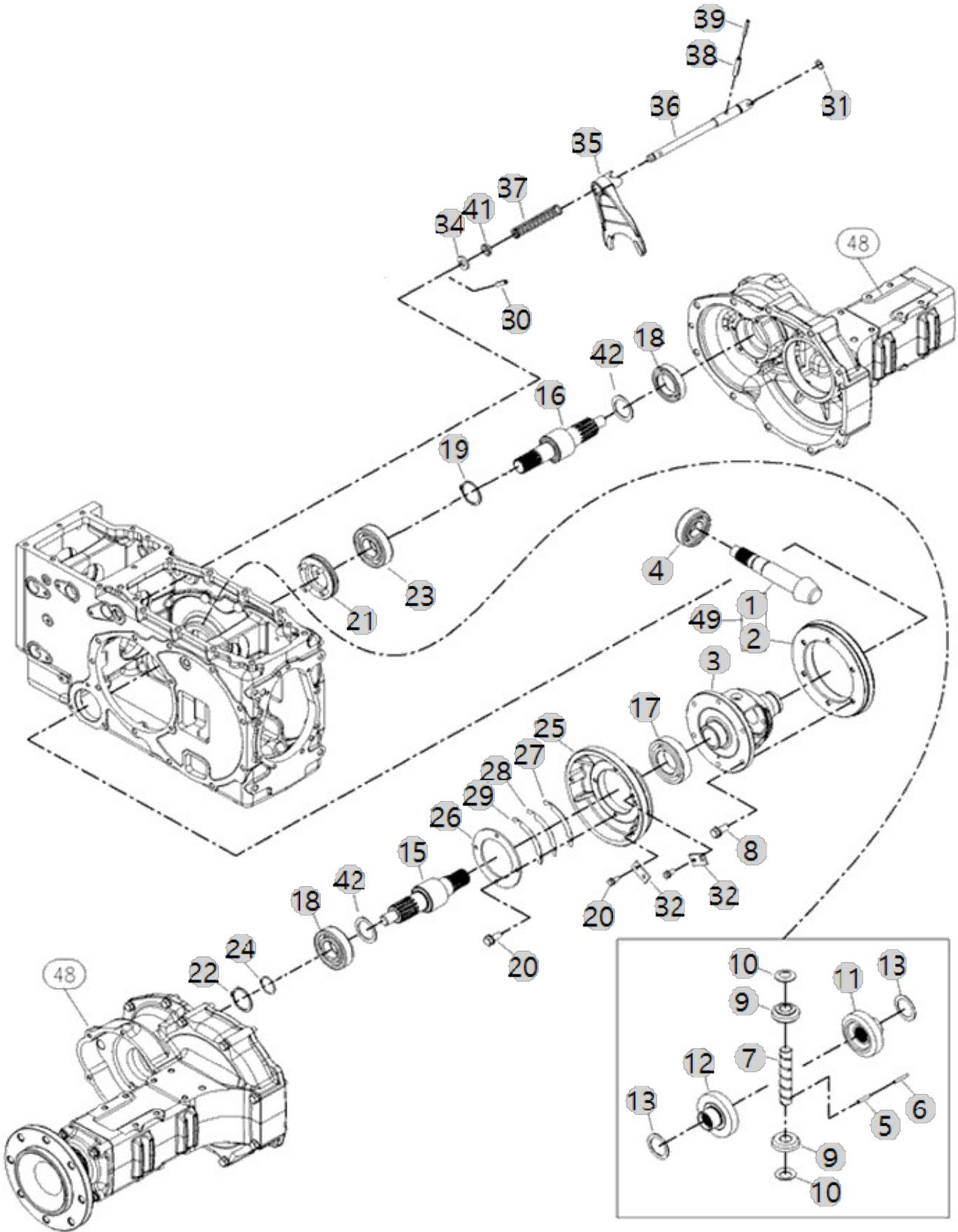

F06030

25CABIN TM총조합
(NEC)(AC01457)

BRAKE

Year/Month

2022-12-19

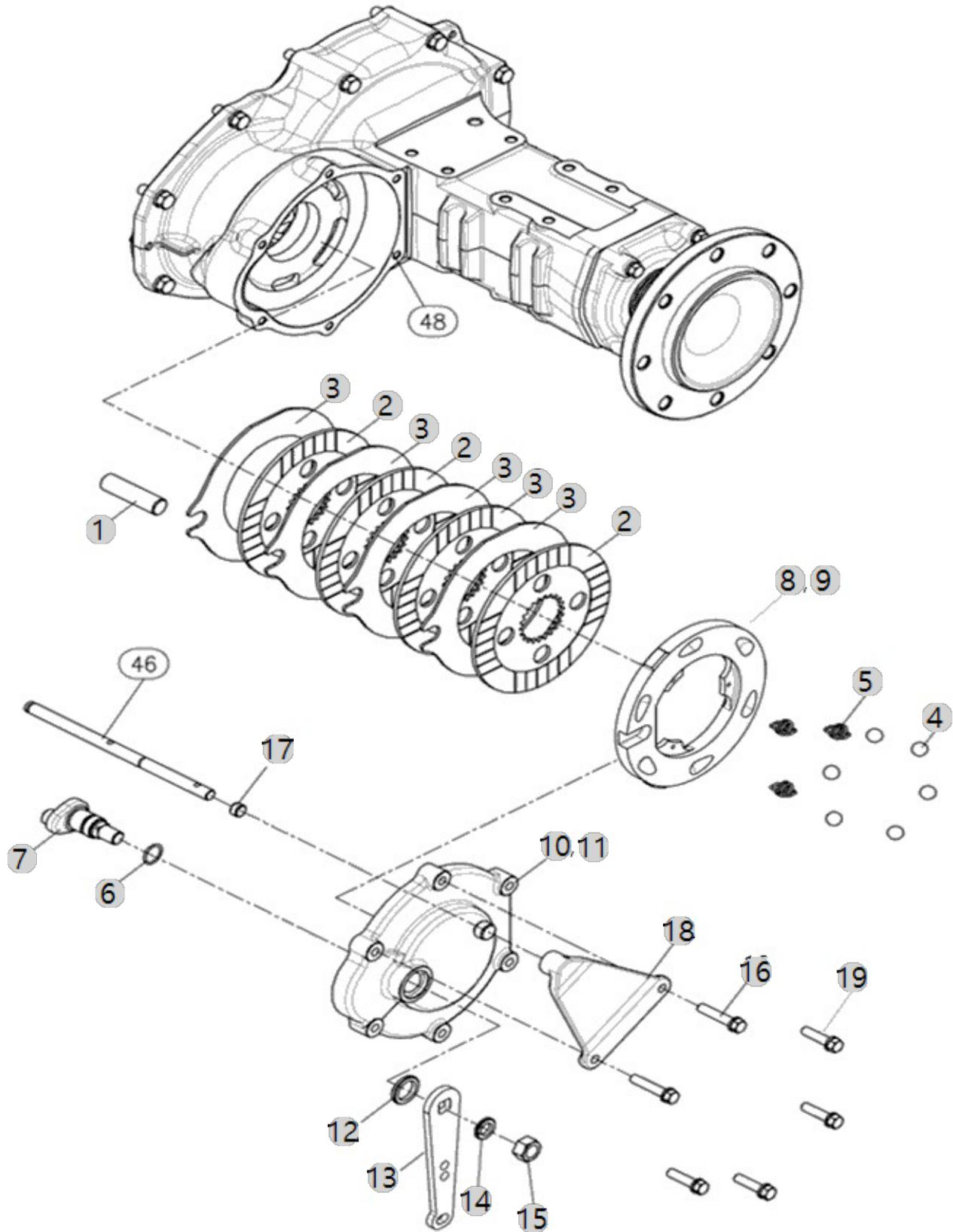

F07000

25CABIN TM총조합
(NEC)(AC01457)

PTO

Year/Month

2022-12-19

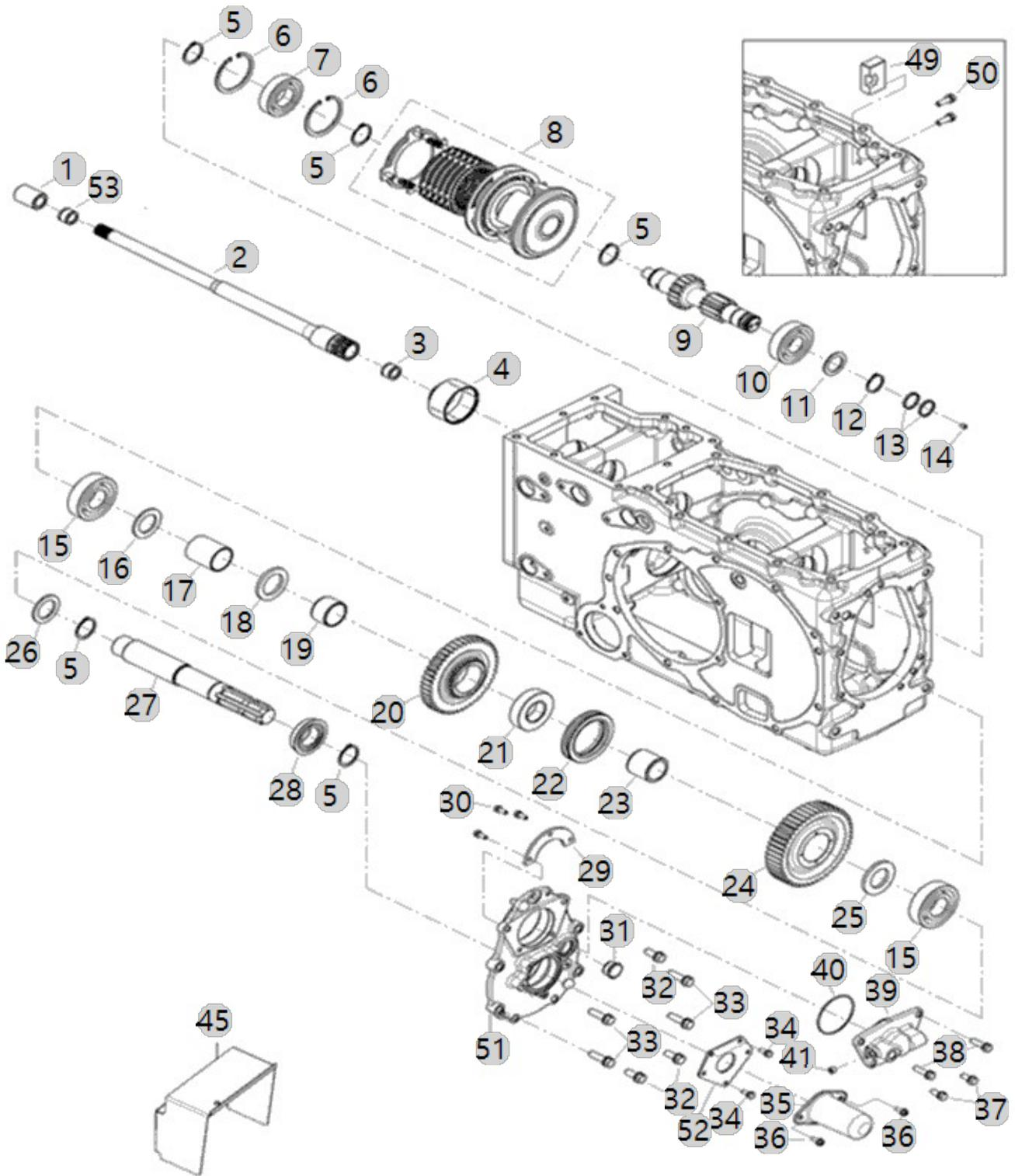

F07000 25CABIN TM총조합 (NEC)(AC01457)		PTO				Year/Month 2022-12-19
순번 (NO)	부품번호 (PART NO)	품명 (PART NAME)	품명 (PART NAME)	수량 (QTY)	규격 (SPEC)	비고 (REMARK)
1	TZ43010000A3	변속축연결칼라(20용)	COLLAR,COUPLING	1		
2	TA00015848A	PTO연결축(HST)20	PTO SHAFT(HST)	1		
3	24161-182417	니들베어링	Bearing, Neddle (#18-24-17)	1	KT182417	
4	NT45480000A3	PTO커플링	PTO COUPLING	1		
5	22242-000350	축용스냅링35	SNAP RING, SHAFT (Φ 35)	5	D35	
6	22252-000720	구멍용스냅링72	RING, CIRCLIP (Φ 72)	2	D72	
7	24101-062074	볼베어링6207	BALL BEARING (#6207)	1	#6207	DEL.20220323
8	TA00026514D	PTO클러치팩	PTO CLUTCH PACK	1		
9	NT45920000A2	PTO변속축	SHAFT, PTO SHIFT	1		
10	24101-063064	볼베어링6306	Bearing, Ball (#6306)	1	#6306	DEL.20220323
11	TN45520000A4	칼라	COLLAR	1		
12	22242-000300	축용스냅링30	SNAP RING, SHAFT (Φ 30)	1	D30	
13	TT64070000B4	시일링	SEAL RING	2	26X30X3	
14	TT64080000A4	멈춤나사 M7X1	RETAININGSCREWM7X1	1	M7XP1.0	
15	24101-063074	볼베어링6307	Bearing, Ball (#6307)	2	#6307	DEL.20220323
16	NT45670000B4	스러스트와셔	THRUST WASHER	1	3.0T	
17	NT45680000B4	스페이서	SPACER	1	D45XT2.6	
18	NT45440000C4	칼라	COLLAR	1		
19	TA00033210A	니들부시D	NEEDLE BUSH D	2		
20	TA00033211C	PTO기어46T	GEAR 46T, PTO	1		
21	TZ45100000B3	PTO허브	HUB,P.T.O	2		
22	TZ45110000C4	PTO슬리브	SLEEVE,P.T.O	2		
23	TA00033209A	니들부시B	NEEDLE BUSH B	1		
24	TA00033212C	PTO기어49T	GEAR 49T, PTO	1		
25	TZ45140000B4	칼라	COLLAR	1	5T	
26	TN45120000A4	와셔	WASHER	1	T3.0X60X60	
27	NT45130000B3	PTO축	shaft, PTO	1		
28	TT62040000A3	PTO 오일실 QLF35X60X19	PTO OIL SEAL QLF35X60X19	1	35X60X19	
29	NT45640000A4	베어링커버	Bearing Cover	1		
30	26013-060162	와셔조립육각볼트(+SW)	Bolt, Hexa (6-16)	3	M6XP1.0X16	
31	TCA8130000A4	검유창	SIGHTGLASS -> NT45690000A4	1		
32	26013-100252	와셔조립육각볼트(+SW)	SCREW, CAPTIVE WASHER CAP	3	M10X1.50X02	
33	26013-100352	볼트	Bolt, Hexa (10-35)	4		
34	26013-060162	와셔조립육각볼트(+SW)	Bolt, Hexa (6-16)	3	M6XP1.0X16	
35	TT80030000A3	P.T.O커버	P.T.OCOVER	1		
36	26106-060162	육각플랜지 볼트	HEXFLANGEBOLT	2	M6XP1.0X16	
37	26013-080202	와셔조립육각볼트(+SW)	Bolt, Hexa (8-20)	2	M8XP1.25X20	
38	26013-080302	와셔조립육각볼트(+SW)	HEX BOLT W/WASHER	2	M8XP1.25X30	
39	NT45620000A3	실케이스	SEAL CASE	1		
40	24341-000700	O링(70-S)	O-RING, FIX (Φ70)	1	1A S70.0	
41	23871-010000	테이퍼플러그	PLUG	1	PT1/8	
45	TA00062857A	PTO커버	COVER, PTO	1		
45	TA00062857B	PTO커버	COVER, PTO	1		
49	NT45980000A4	브레이크잡이	BRAKE HOLDER	1		
50	26013-080252	와셔조립육각볼트(+SW)	Bolt, Hexa (8-25)	2	M8XP1.25X25	

F07050

25CABIN TM총조합
(NEC)(AC01457)

PTO VALVE

Year/Month

2022-12-19

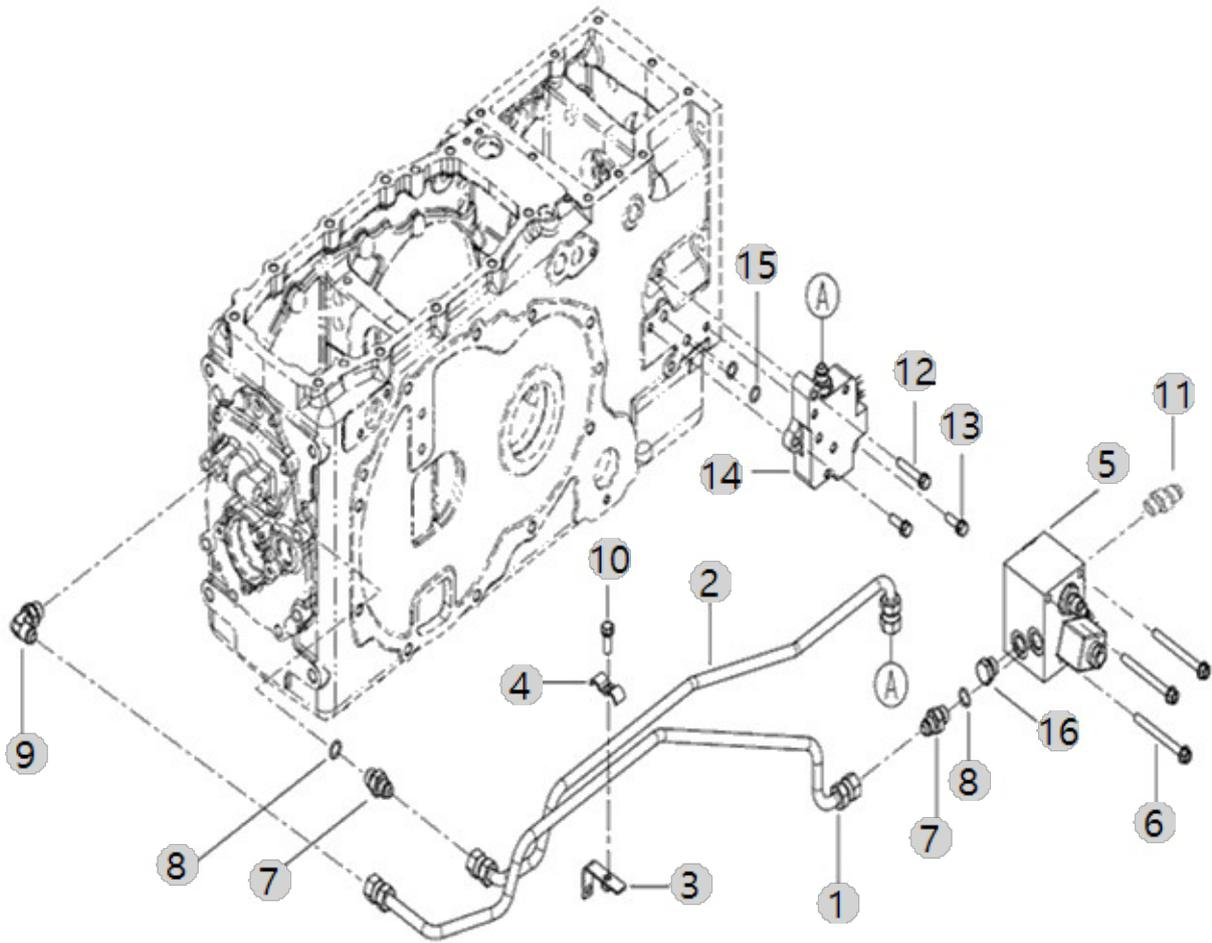

F07120

25CABIN TM총조합
(NEC)(AC01457)

ROD ASSY, PTO & 4WD

Year/Month

2022-12-19

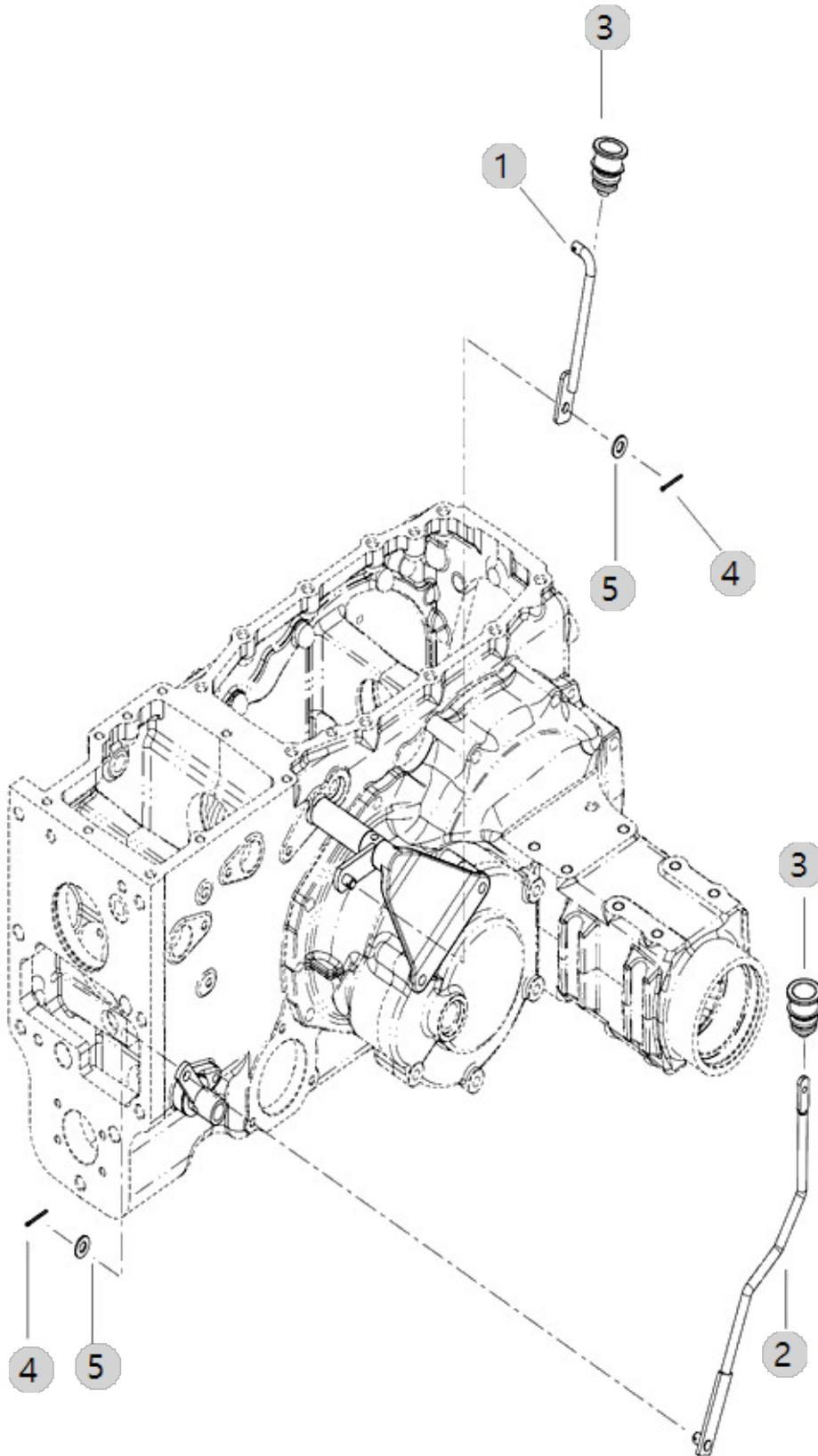

F08060

25CABIN TM총조합
(NEC)(AC01457)

FORK, PTO SHIFT

Year/Month

2022-12-19

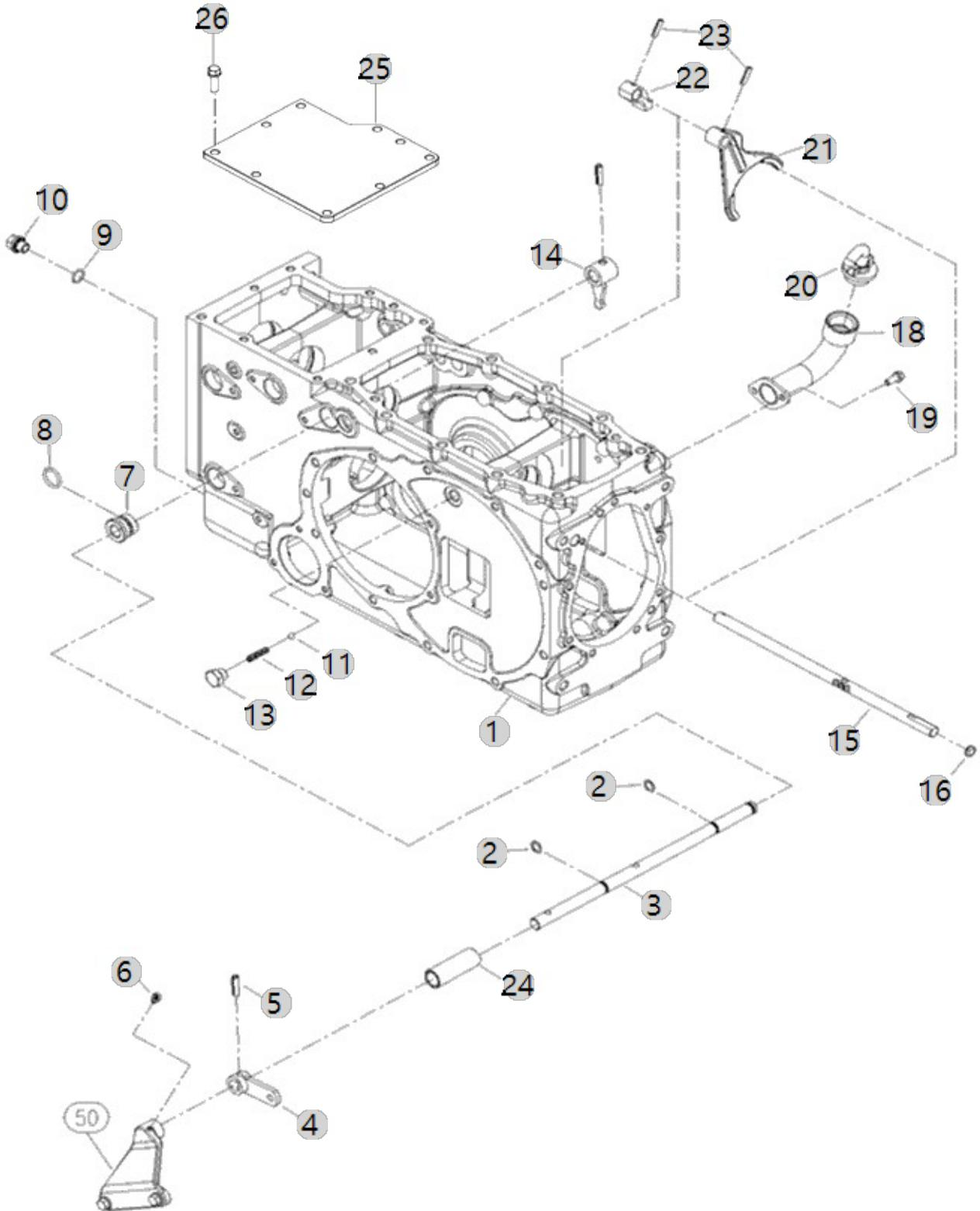

F10020

25CABIN TM총조합
(NEC)(AC01457)

LIFT ARM

Year/Month

2022-12-19

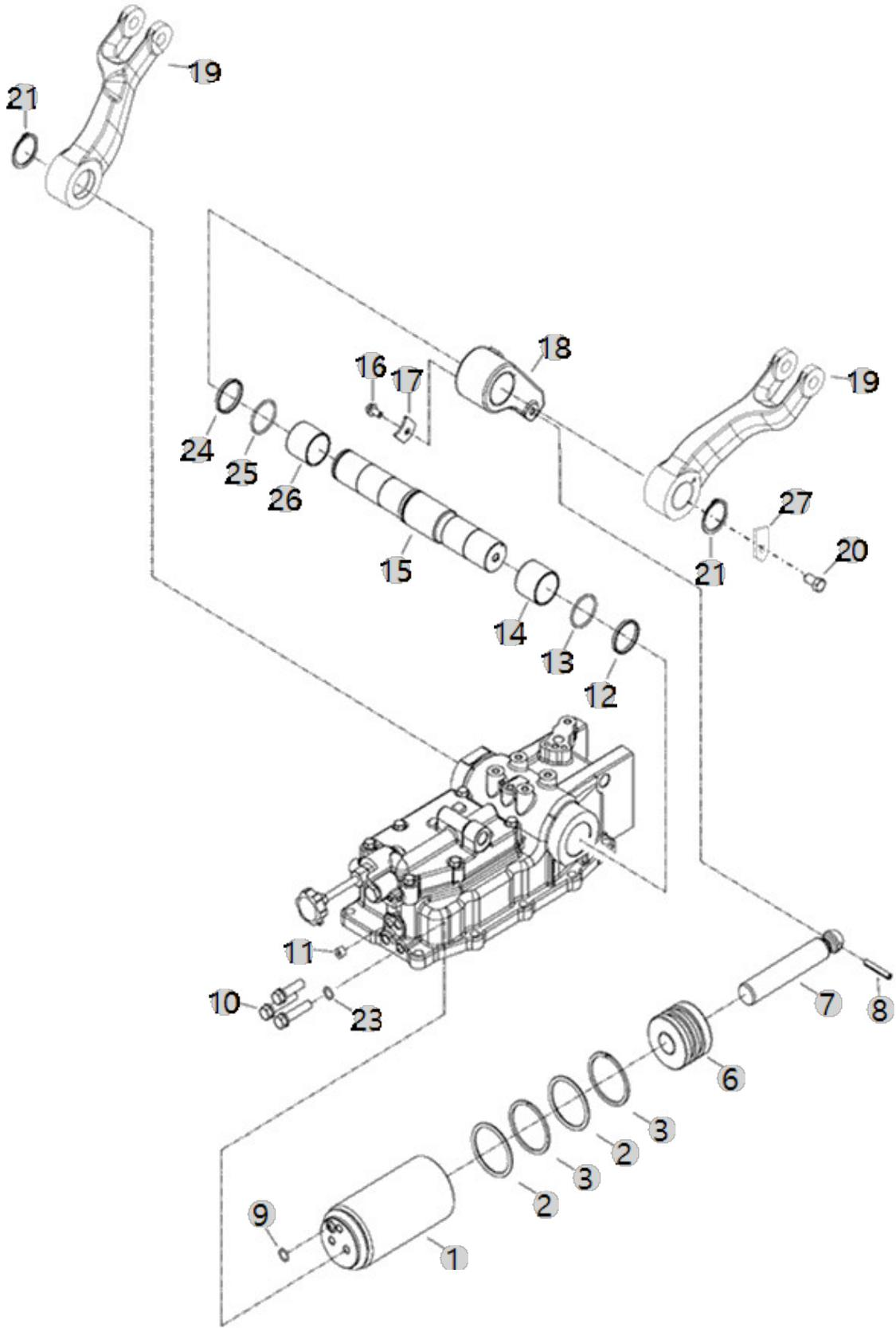

F10030

25CABIN TM총조합
(NEC)(AC01457)

SAFTY VALVE

Year/Month

2022-12-19

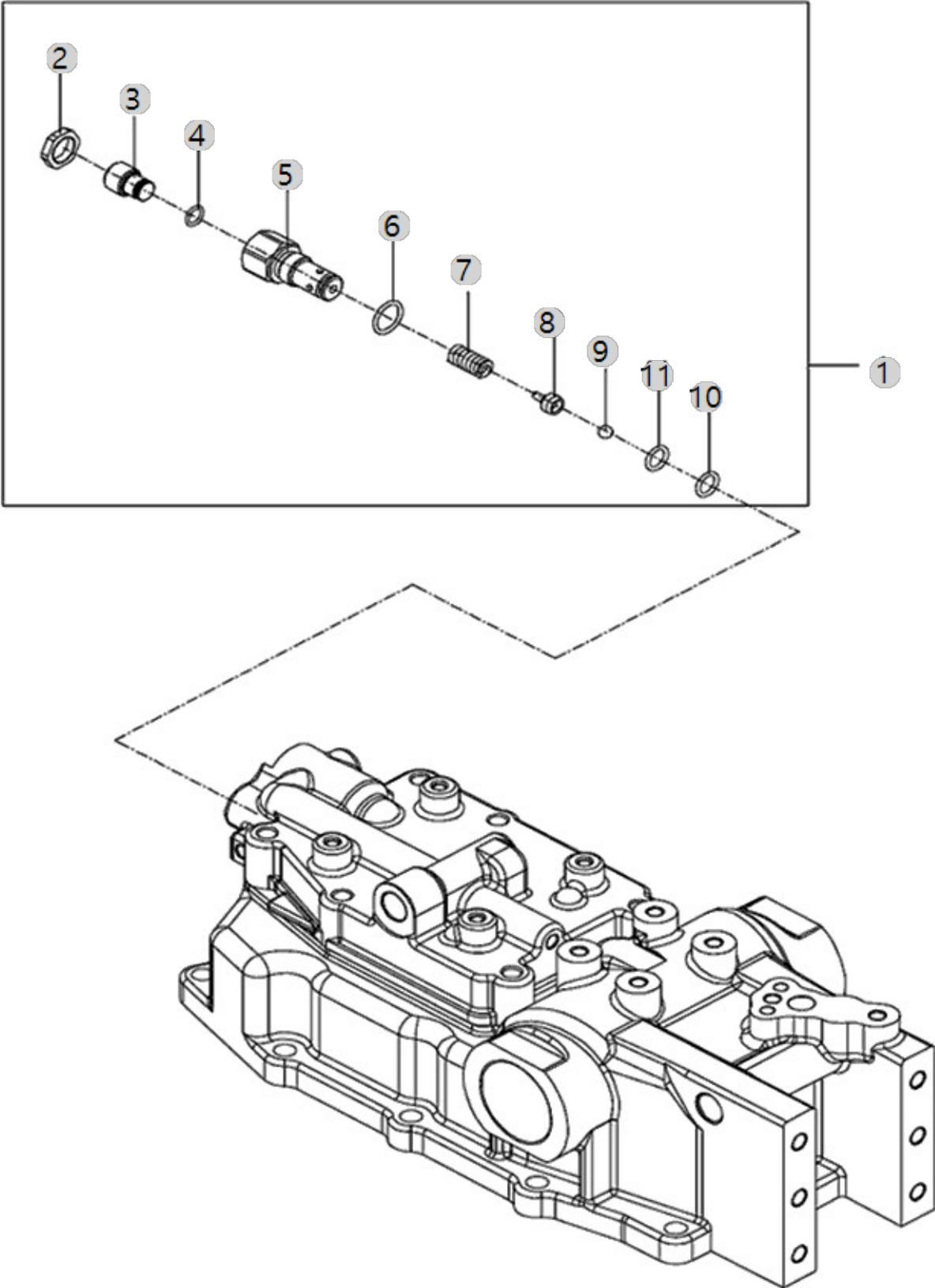

F10040

25CABIN TM총조합
(NEC)(AC01457)

STOP VALVE

Year/Month

2022-12-19

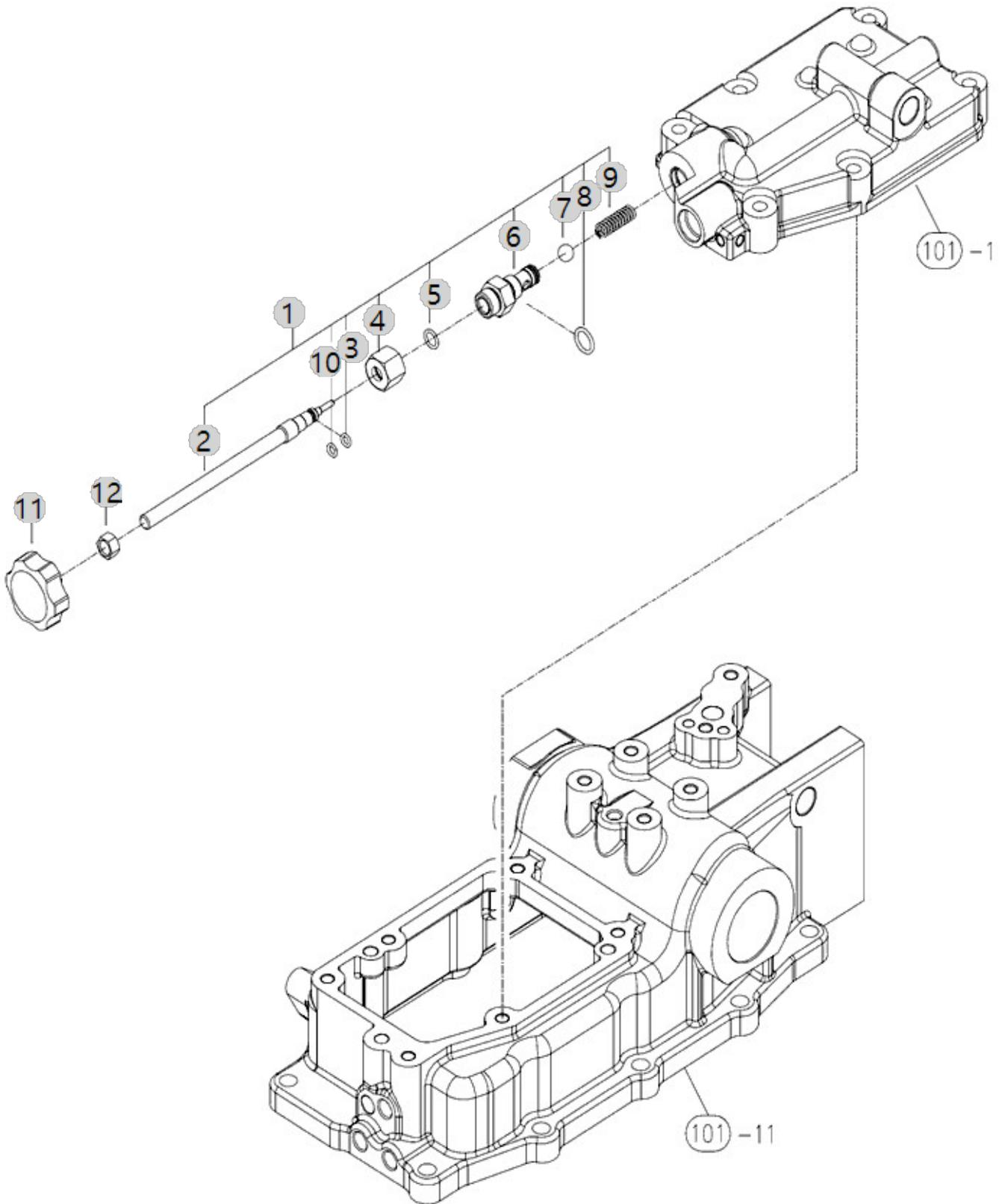

F10061

25CABIN TM총조합
(NEC)(AC01457)

DRAFT/ POSITION CONTROL LEVER

Year/Month

2022-12-19

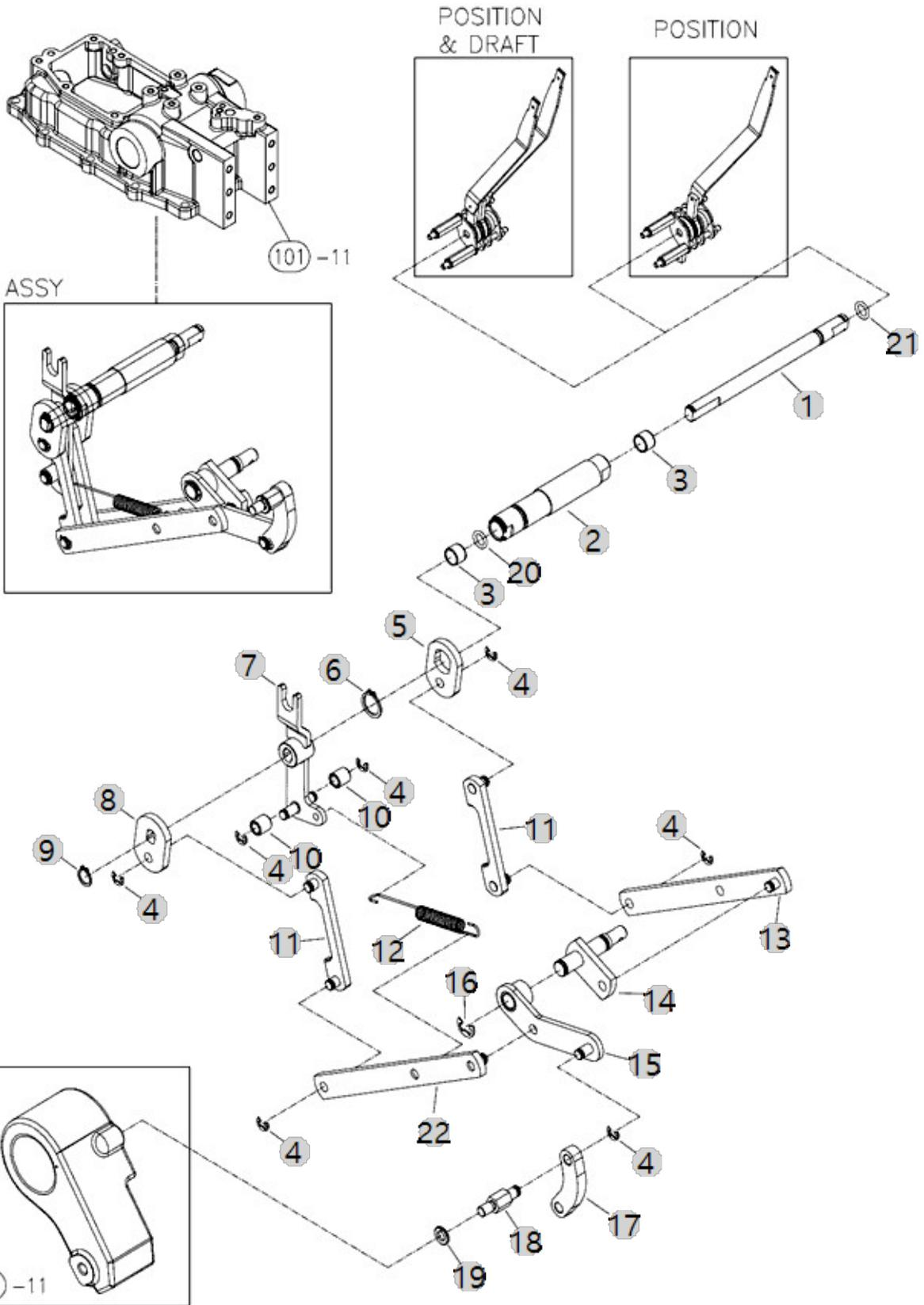

F10063

25CABIN TM총조합
(NEC)(AC01457)

DRAFT CONTROL

Year/Month

2022-12-19

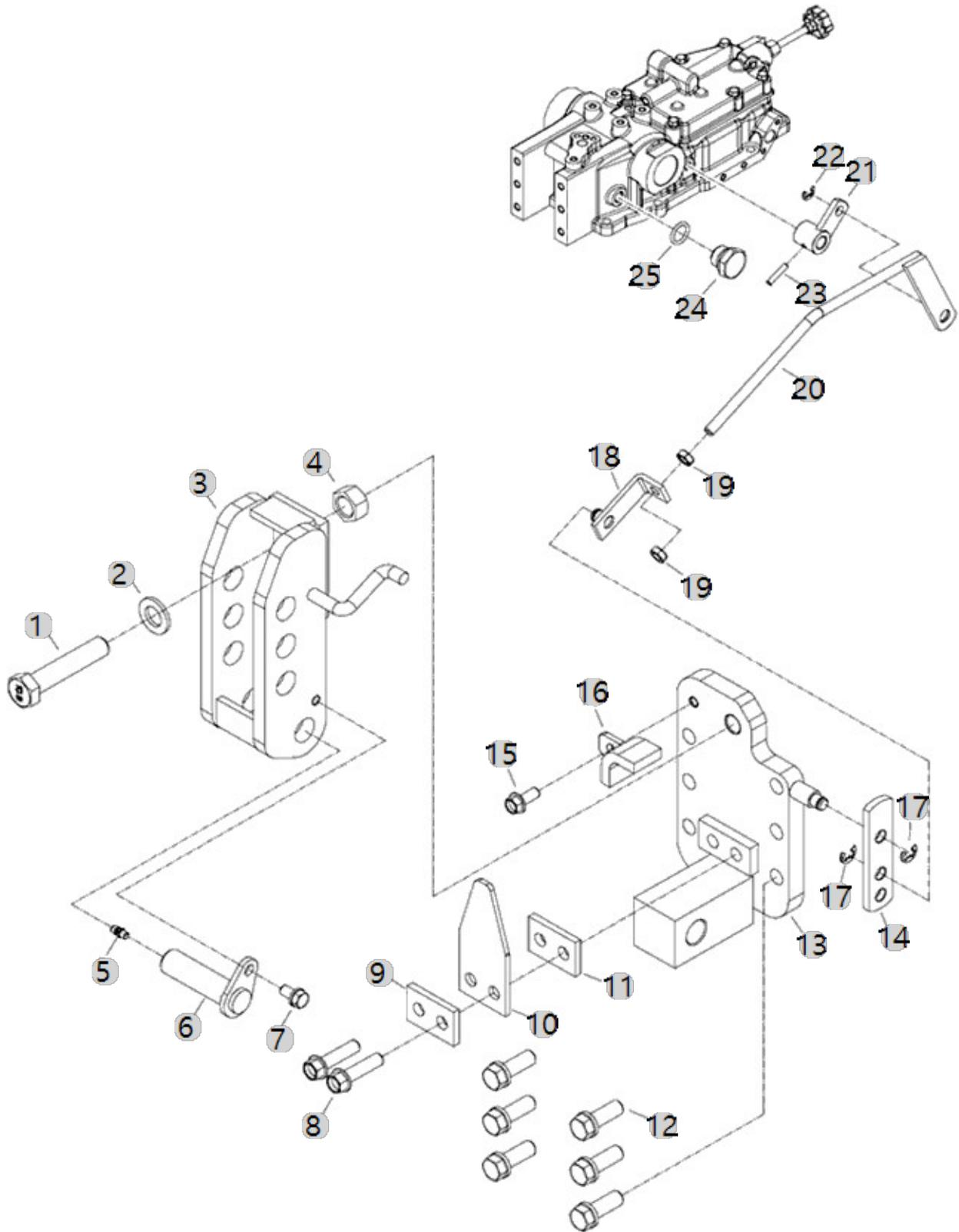

F10064

25CABIN TM총조합
(NEC)(AC01457)

POSITION CONTROL LEVER

Year/Month

2022-12-19

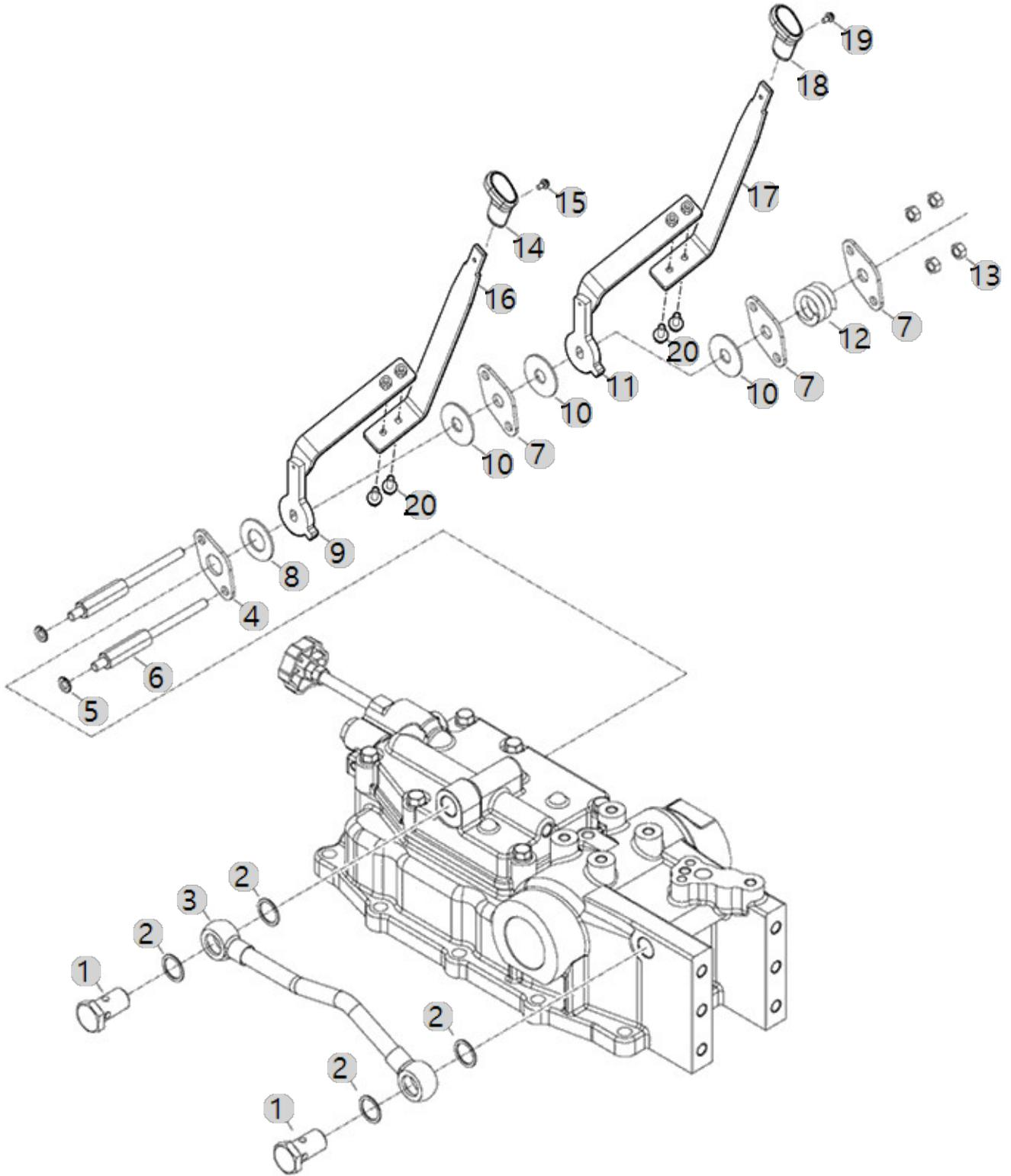

F10120

25CABIN TM총조합
(NEC)(AC01457)

REAR SCV

Year/Month

2022-12-19

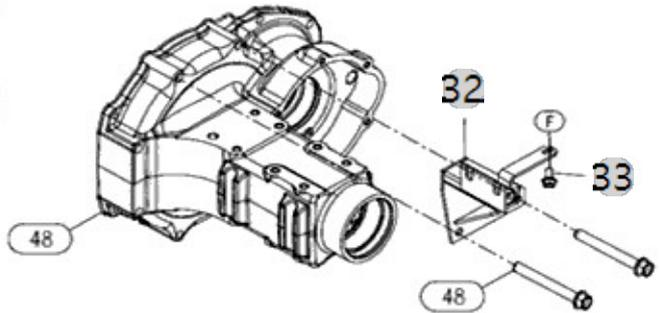
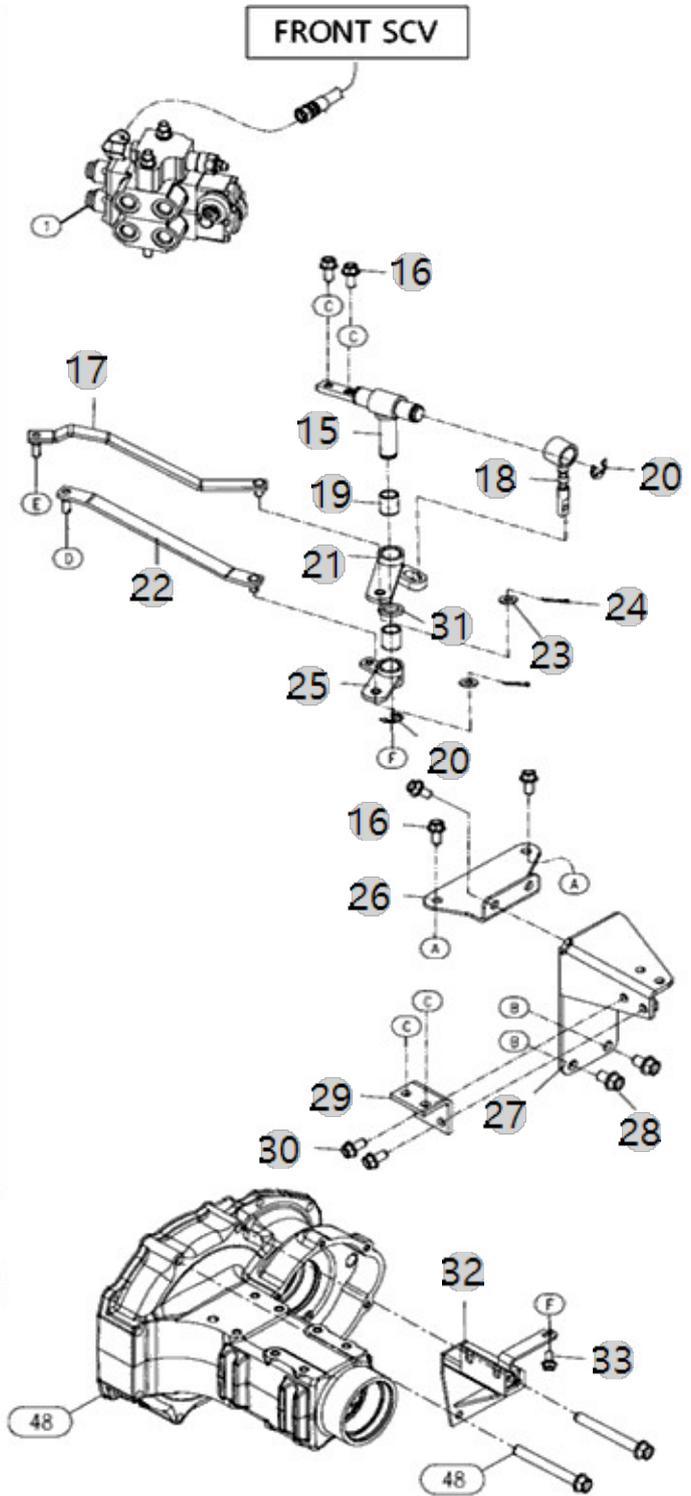
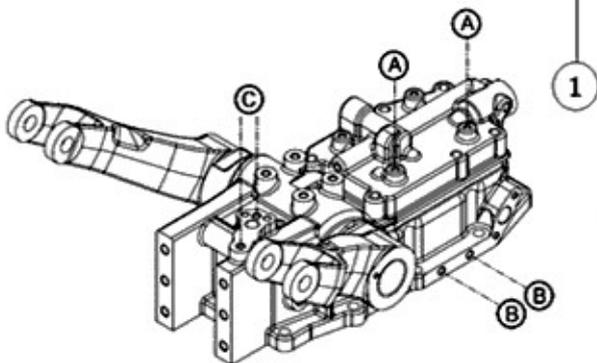
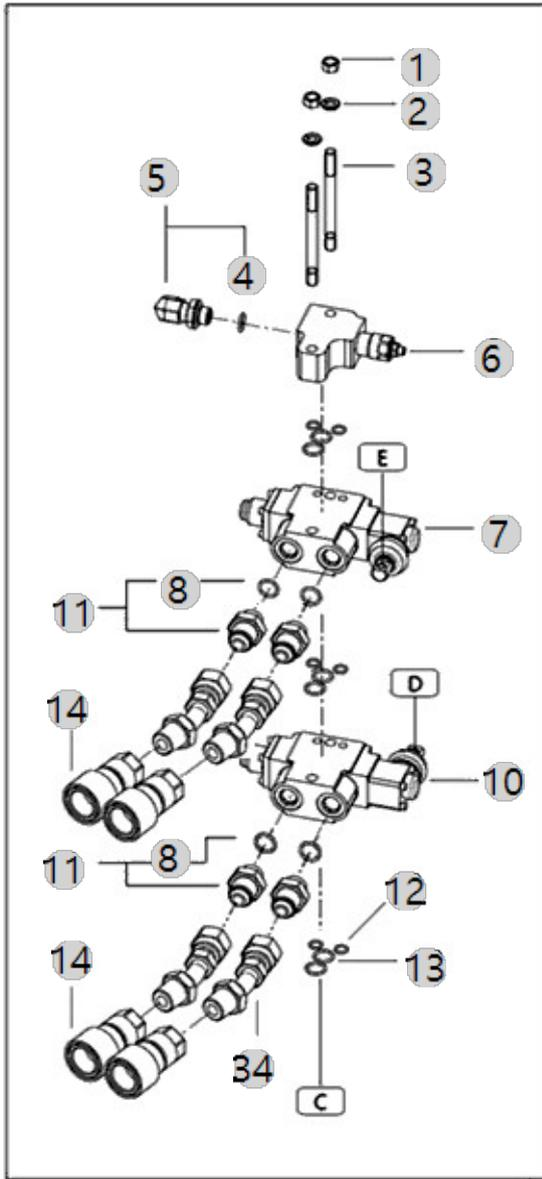

F11020

25CABIN TM총조합
(NEC)(AC01457)

FRONT DRIVE & RANGE SHIFT LEVER

Year/Month

2022-12-19

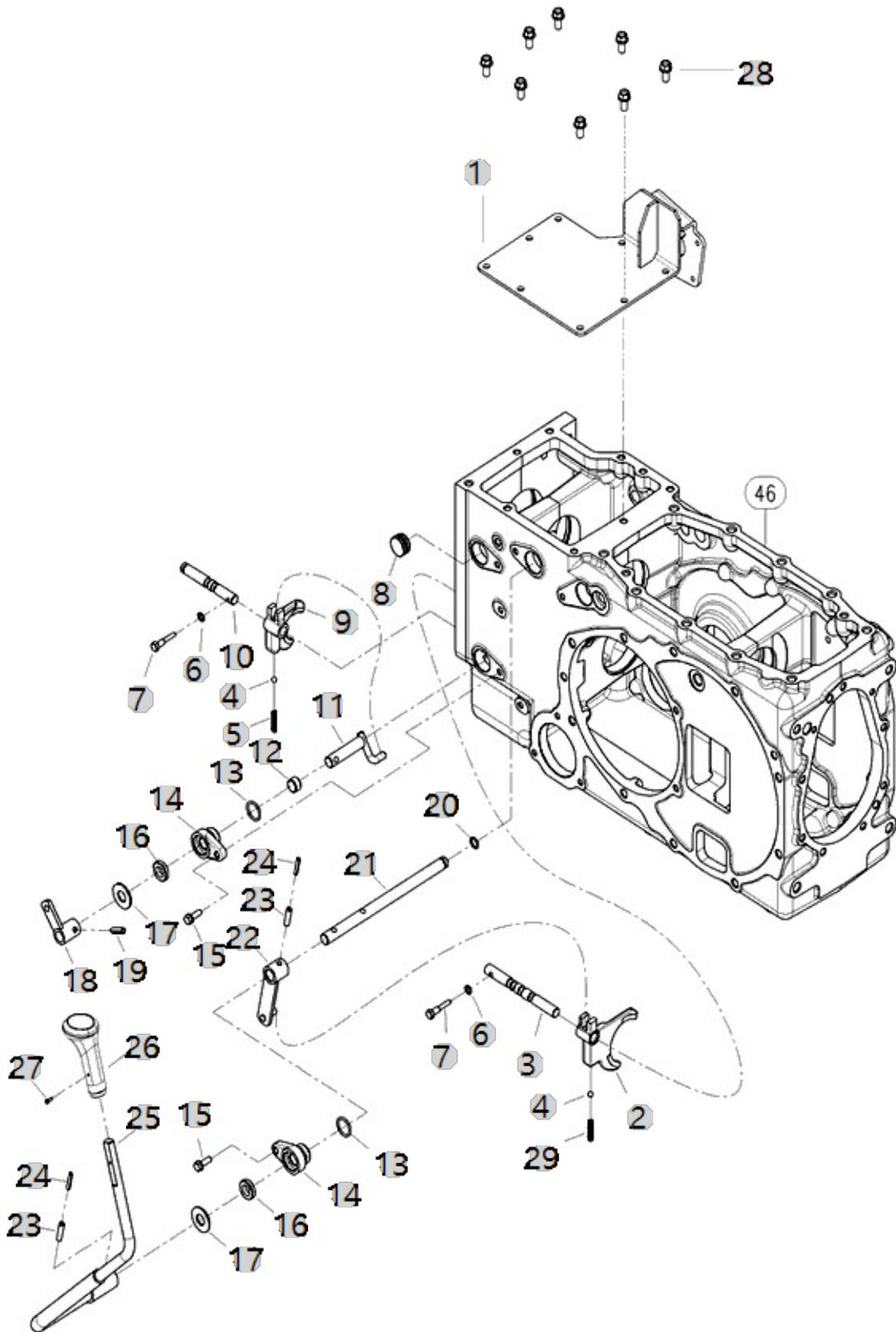

G01020

6225C(EU)(AC02123)

BONNET

Year/Month

2022-12-19

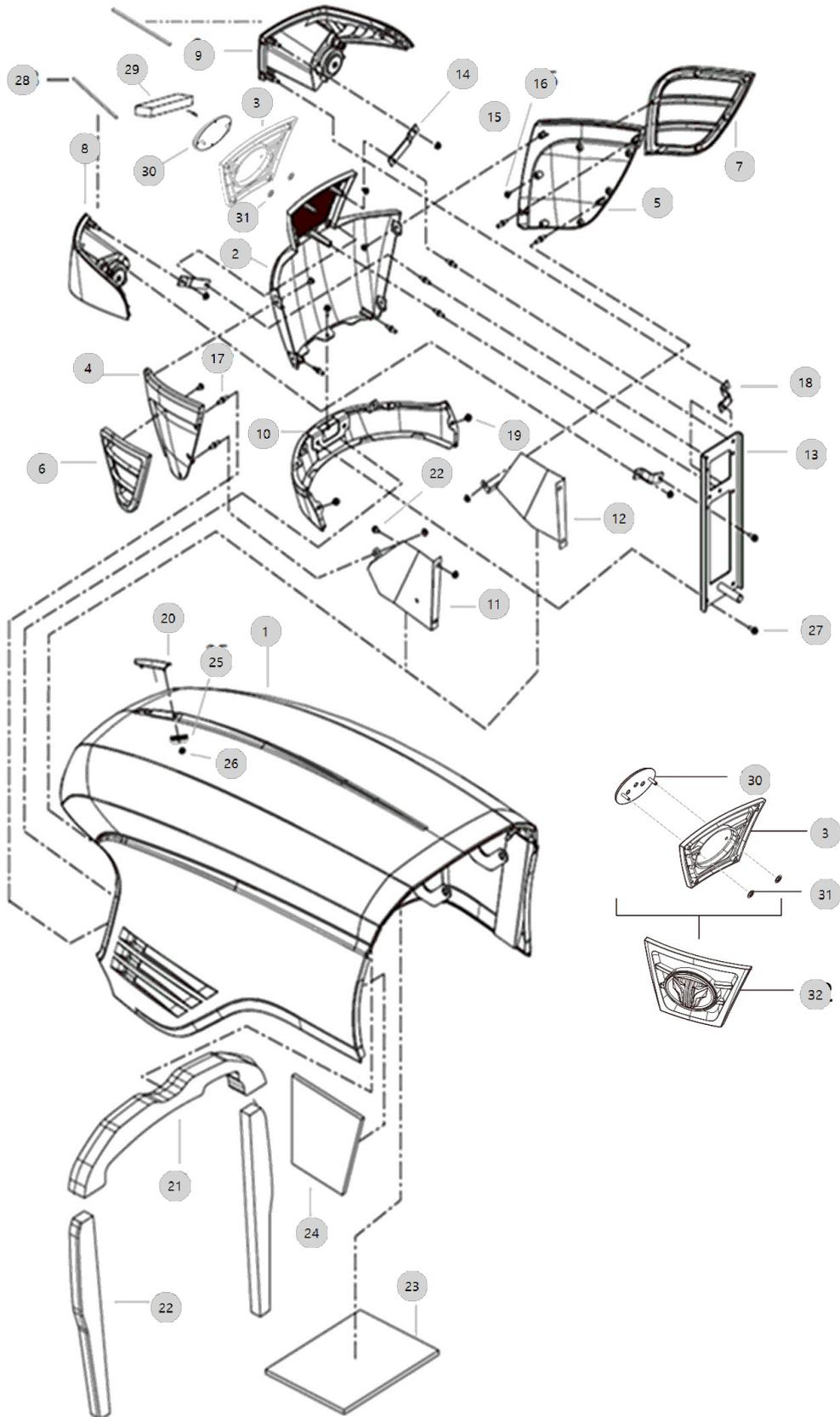

G01040

LATCHING DEVICE, BONNET

Year/Month

6225C(EU)(AC02123)

2022-12-19

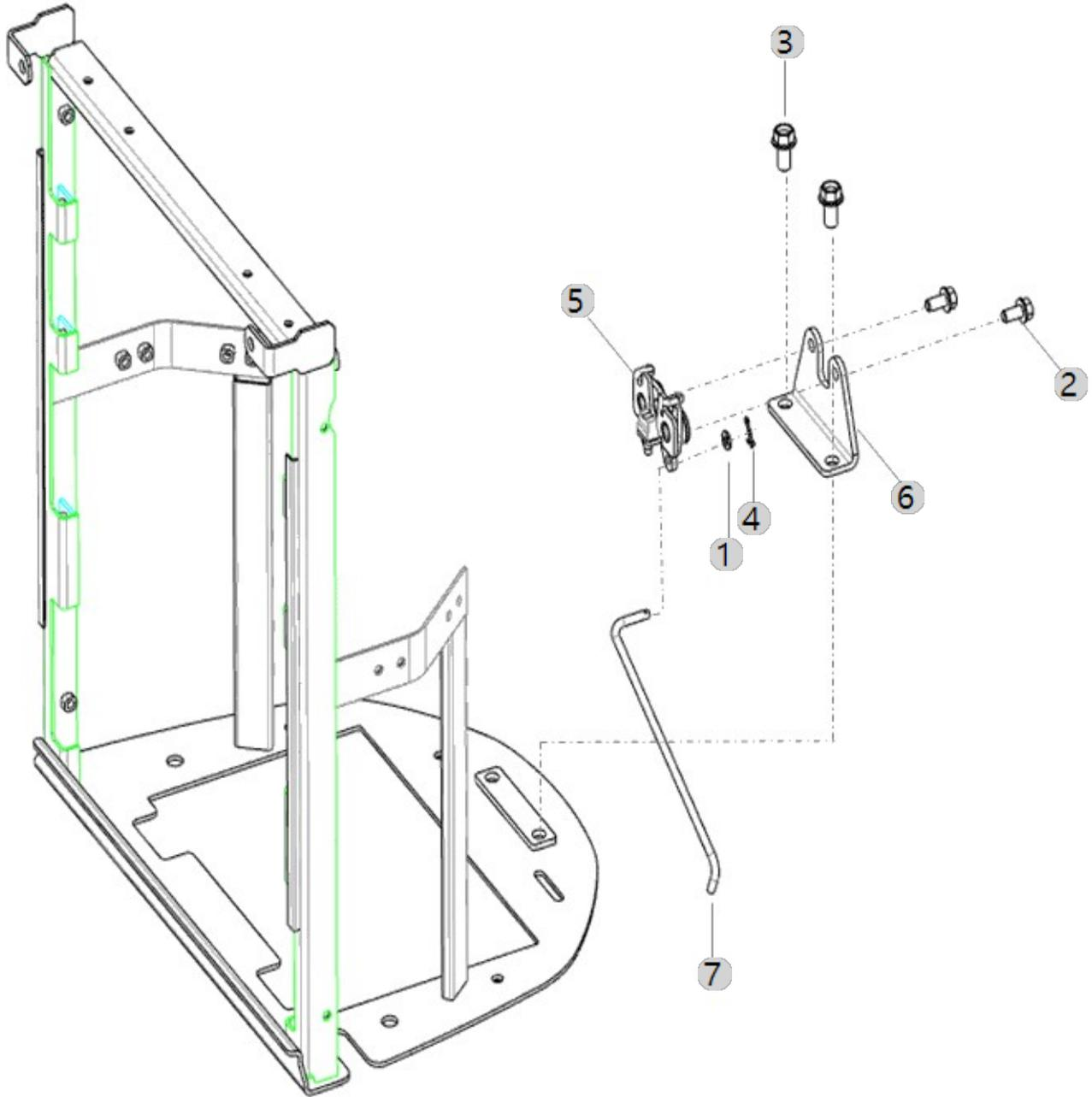

G01060A
6225C(EU)(AC02123)

FIXED BRACKET, BONNET

Year/Month
2022-12-19

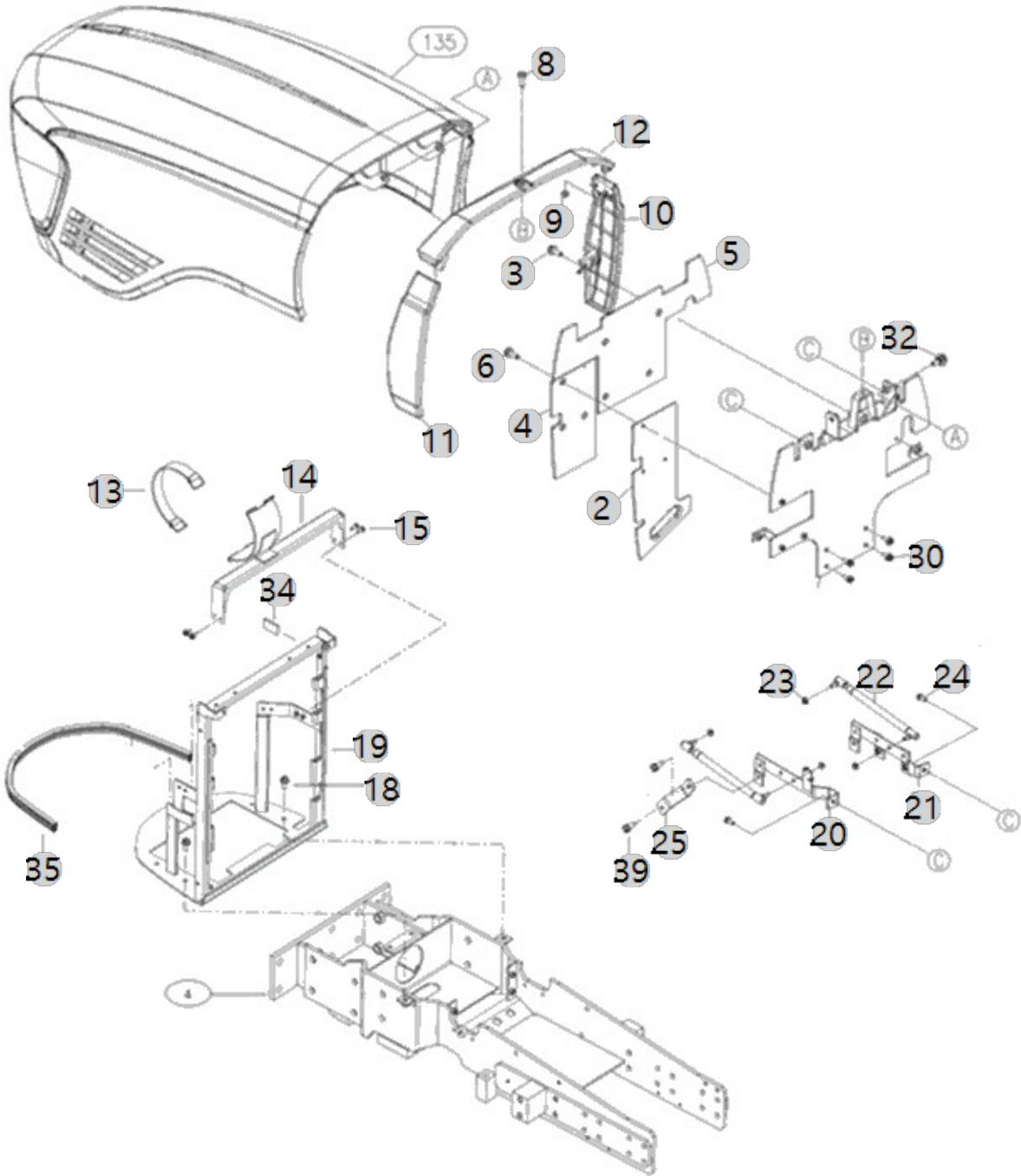

G01080

FRONT AXLE BRACKET

Year/Month

6225C(EU)(AC02123)

2022-12-19

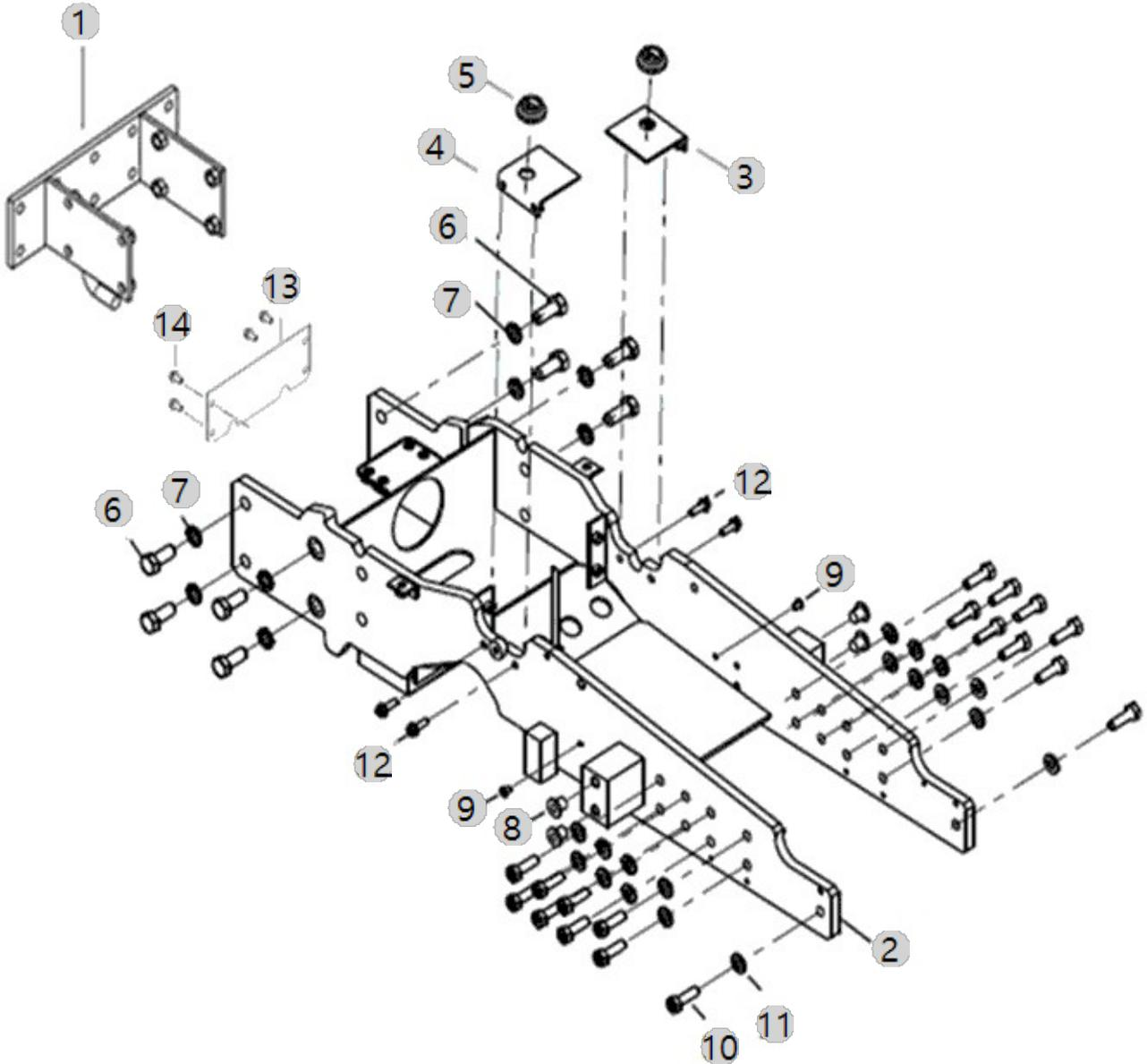

G02010

CABIN FRAME

Year/Month

6225C(EU)(AC02123)

2022-12-19

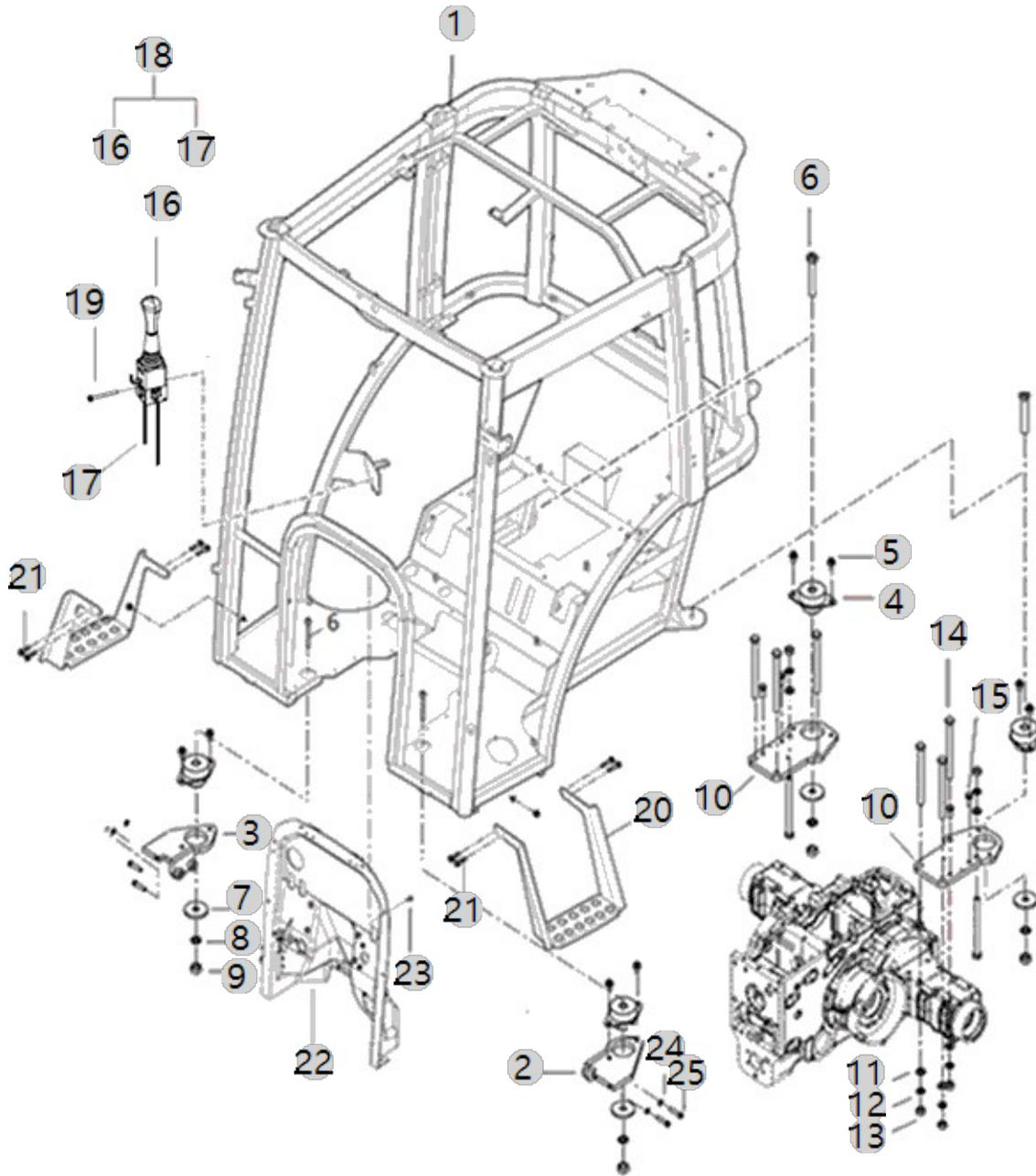

G02010	CABIN FRAME	Year/Month
6225C(EU)(AC02123)		2022-12-19

순번 (NO)	부품번호 (PART NO)	품명 (PART NAME)	품명 (PART NAME)	수량 (QTY)	규격 (SPEC)	비고 (REMARK)
1	TA00063802A	25C캐빈프레임조합_(EU)	25C CABIN FRAME ASSY_(EU)	1		
2	TA00035953B	방진 고무 지지대 앞 조합 (좌)_	SUPPORT ASS'Y	1		
2	TA00035953A	방진 고무 지지대 앞 조합 (좌)_	SUPPORT ASSY	1		
3	TA00036461B	방진고무 지지대 앞(우)	BRACKET, FRONT(R)	1		
3	TA00036461A	방진고무 지지대 앞(우)	BRACKET, FRONT(R)	1		
4	TA00017825B	방진고무조합	CUSHION RUBBER, FRONT	4		
5	26106-120202	육각플랜지볼트	BOLT	8		
6	FTK1320000C4	캐빈취부볼트	BOLT	4	M20XP2.0X12	
7	TH51050000B4	와셔	WASHER	4	8T	
8	22217-200000	스프링 와셔	WASHER, SPRING (Φ 20)	4	M20 X 60 X P	
9	26716-200002	육각너트	NUT	4	M20XP2.5	
10	TA00027276B	캐빈 취부 브래킷 후	BRACKET REAR	2	16T	
10	TA00027276C	캐빈 취부 브래킷 후	BRACKET REAR	2	16T	
11	22137-160000	와셔	WASHER, PLAIN (Φ 16)	8	M16	
12	22217-160000	스프링와셔	WASHER, SPRING (Φ 16)	8	M16	
13	26716-160002	육각너트	NUT	8	M16XP2.0	
14	TTF8170000B4	볼트	BOLT	8	M16X2.0	
15	26013-120302	와셔조립육각볼트(+SW)	HEX BOLT W/WASHER	4	M12XP1.75X3	
16	TA00035126A	조이스틱	JOY-STICK	1		
17	TA00035127A	조이스틱 케이블	JOYSTICK CABLE	1		
18	TA00035125A	조이스틱 조합	JOY-STICK ASS'Y	1		
19	26106-080802	572,A1417,플랜지볼트8X80	SCREW,HEXFLANGEHEADCAP	2	M8X1.25X80	
20	TA00063010A	발판조합_C	STEP ASS'Y	2		
21	26106-080202	육각플랜지볼트	SQR FLANGE BOLT	8	M8XP1.25X20	
22	TA00028579H	방풍판 조합	HEAT INSULATOR ASS'Y	1		
22	TA00028579J	방풍판 조합	WINDSHIELD ASS'Y	1		
22	TA00028579I	방풍판 조합	WINDSHIELD ASS'Y	1		
23	26106-060162	육각플랜지 볼트	HEXFLANGE BOLT	8	M6XP1.0X16	
24	22217-100000	스프링와셔	WASHER, SPRING (Φ 10)	4	M10	
25	CA00001686A	육각볼트M10X45	BOLT HEXAGON M10X45	4		
25	CA00001686B	육각볼트M10X45	BOLT HEXAGON M10X45	4	M10X45(10.9T)	
26	TB26060000A4	플러그7.8	PLUGRUBBER	2		

G02011

PILLAR COVER

Year/Month

6225C(EU)(AC02123)

2022-12-19

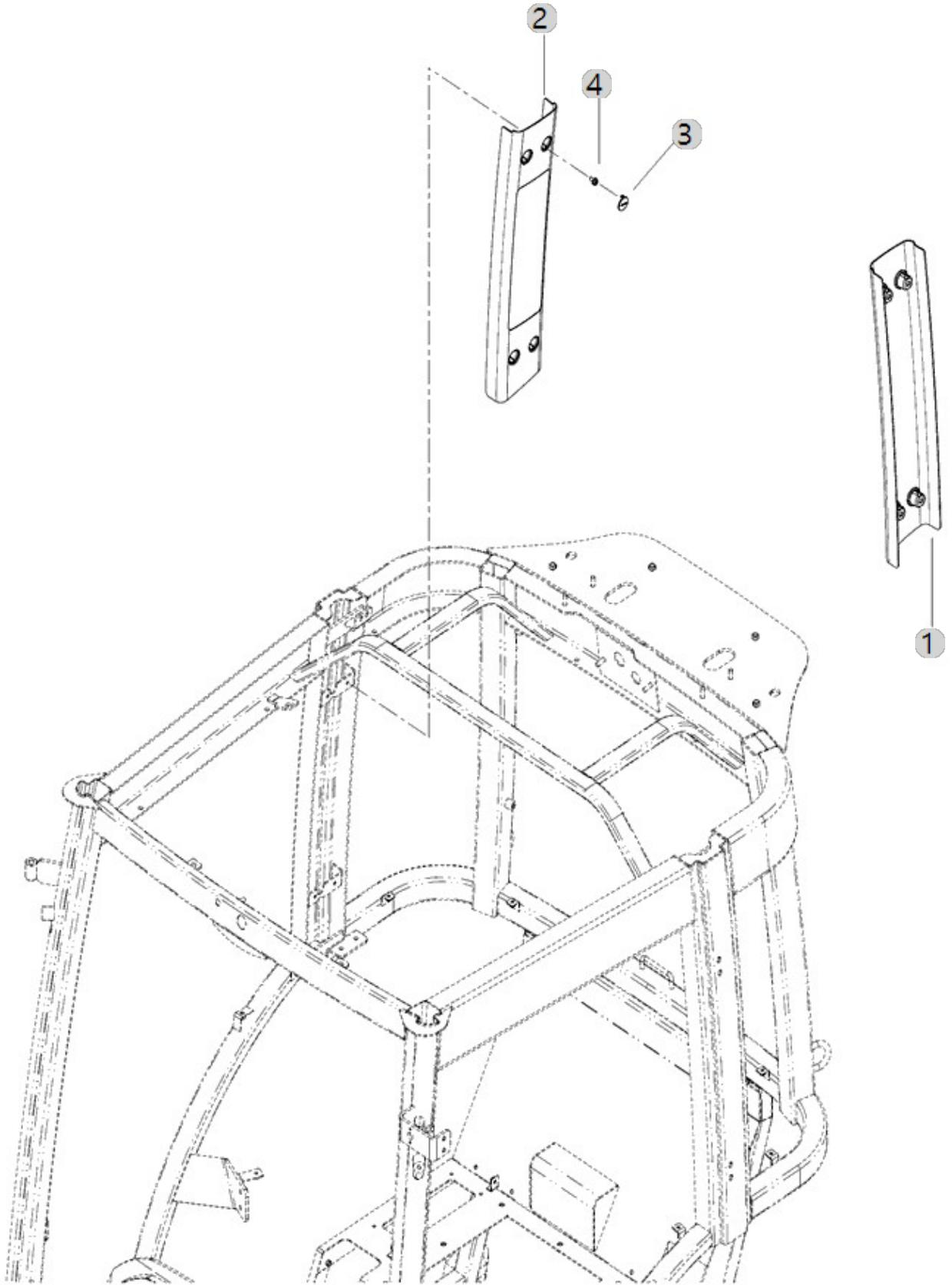

G02020

DASH BOARD

Year/Month

6225C(EU)(AC02123)

2022-12-19

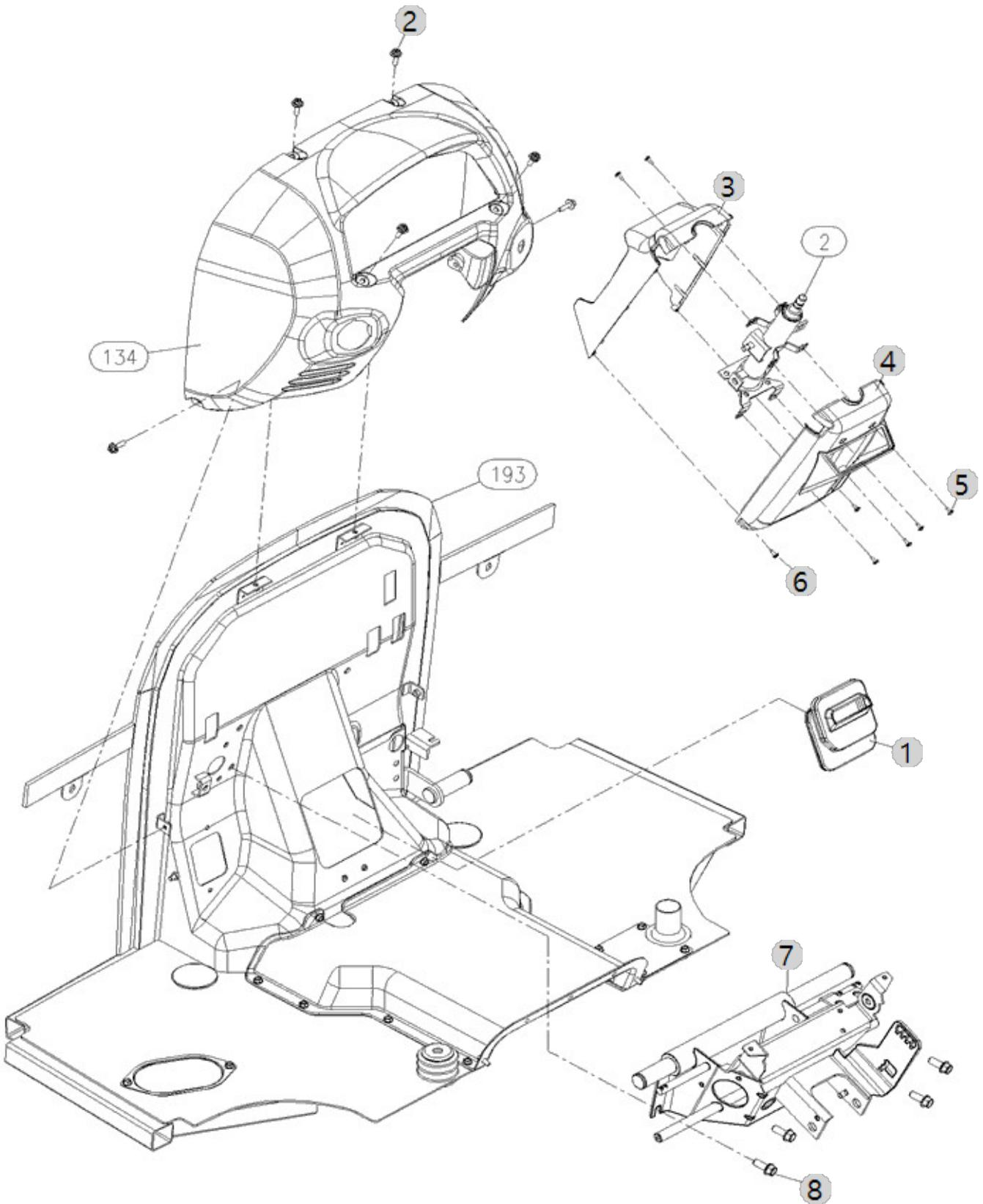

G02030

SIDE MIRROR

Year/Month

6225C(EU)(AC02123)

2022-12-19

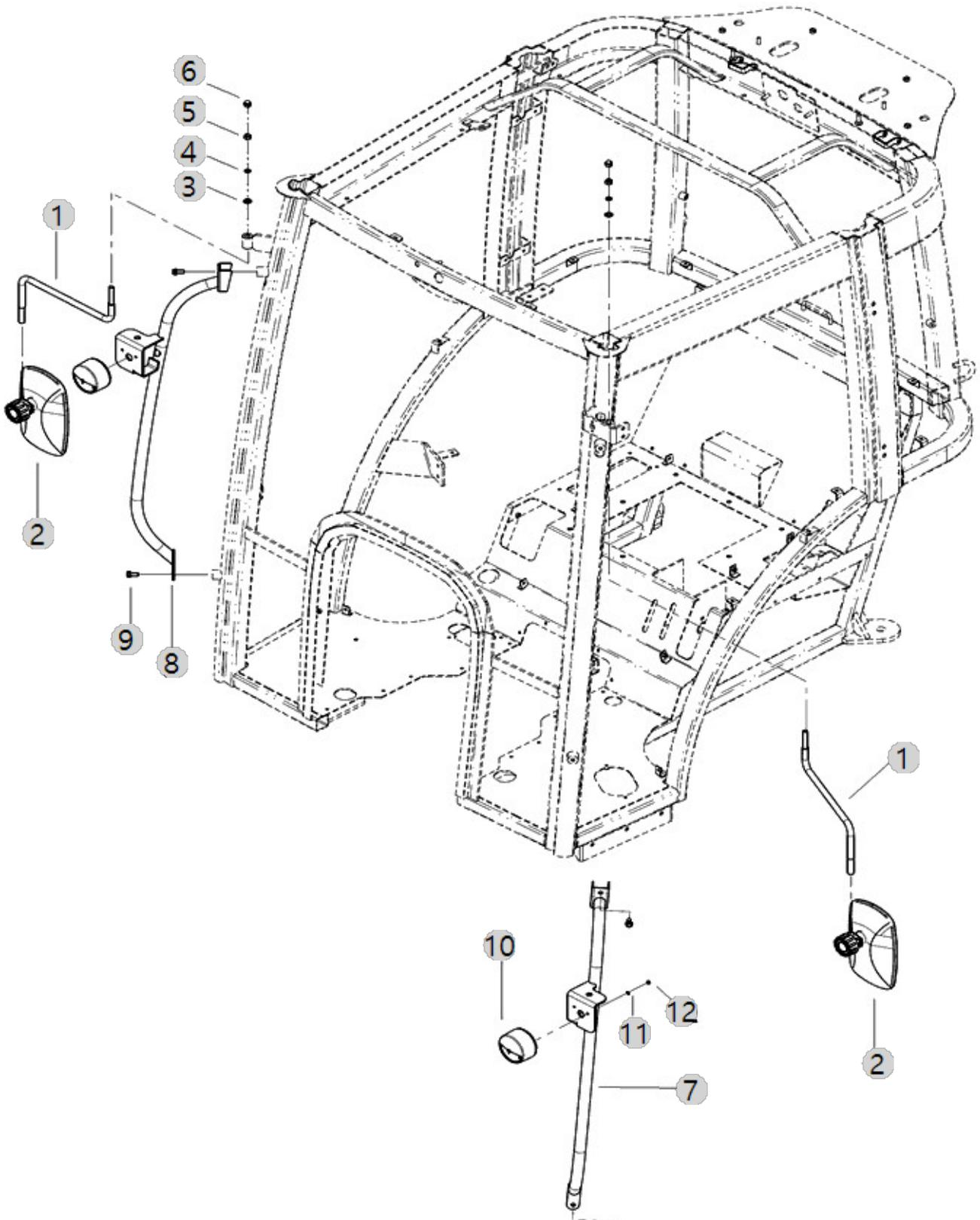

G02050

DOOR ASS'Y

Year/Month

6225C(EU)(AC02123)

2022-12-19

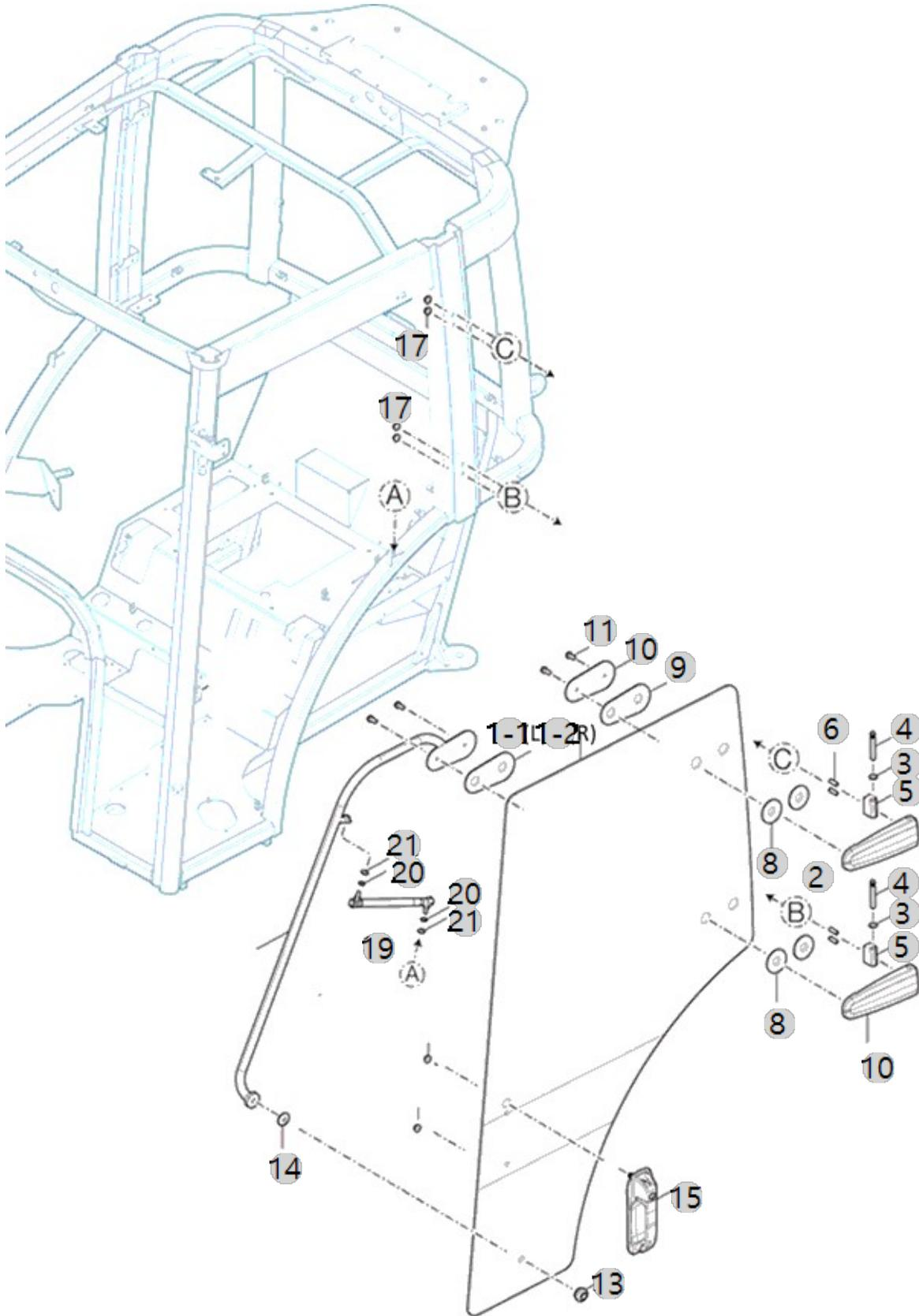

G02071

FRONT WINDOWS

Year/Month

6225C(EU)(AC02123)

2022-12-19

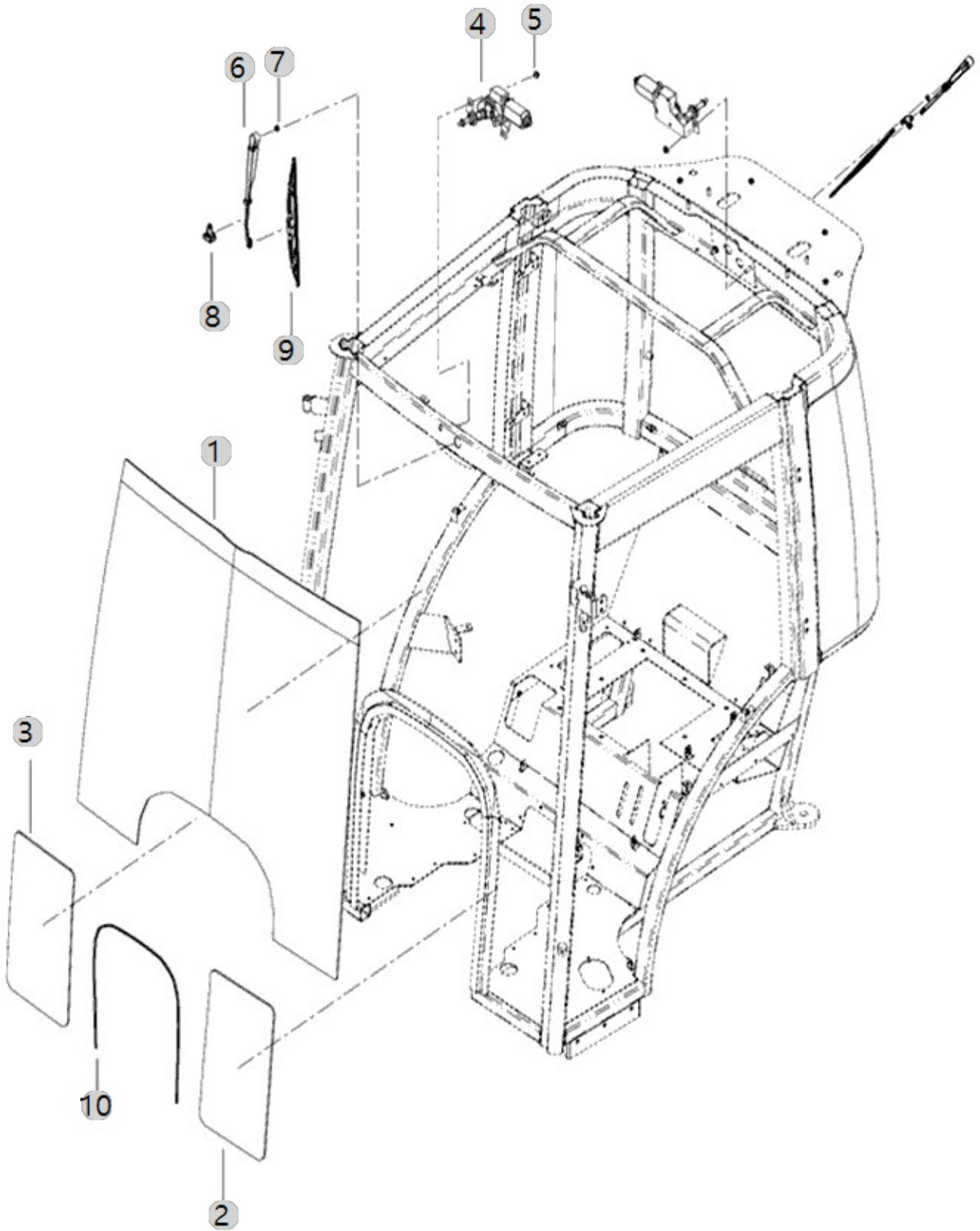

G02072

REAR WINDOWS

Year/Month

6225C(EU)(AC02123)

2022-12-19

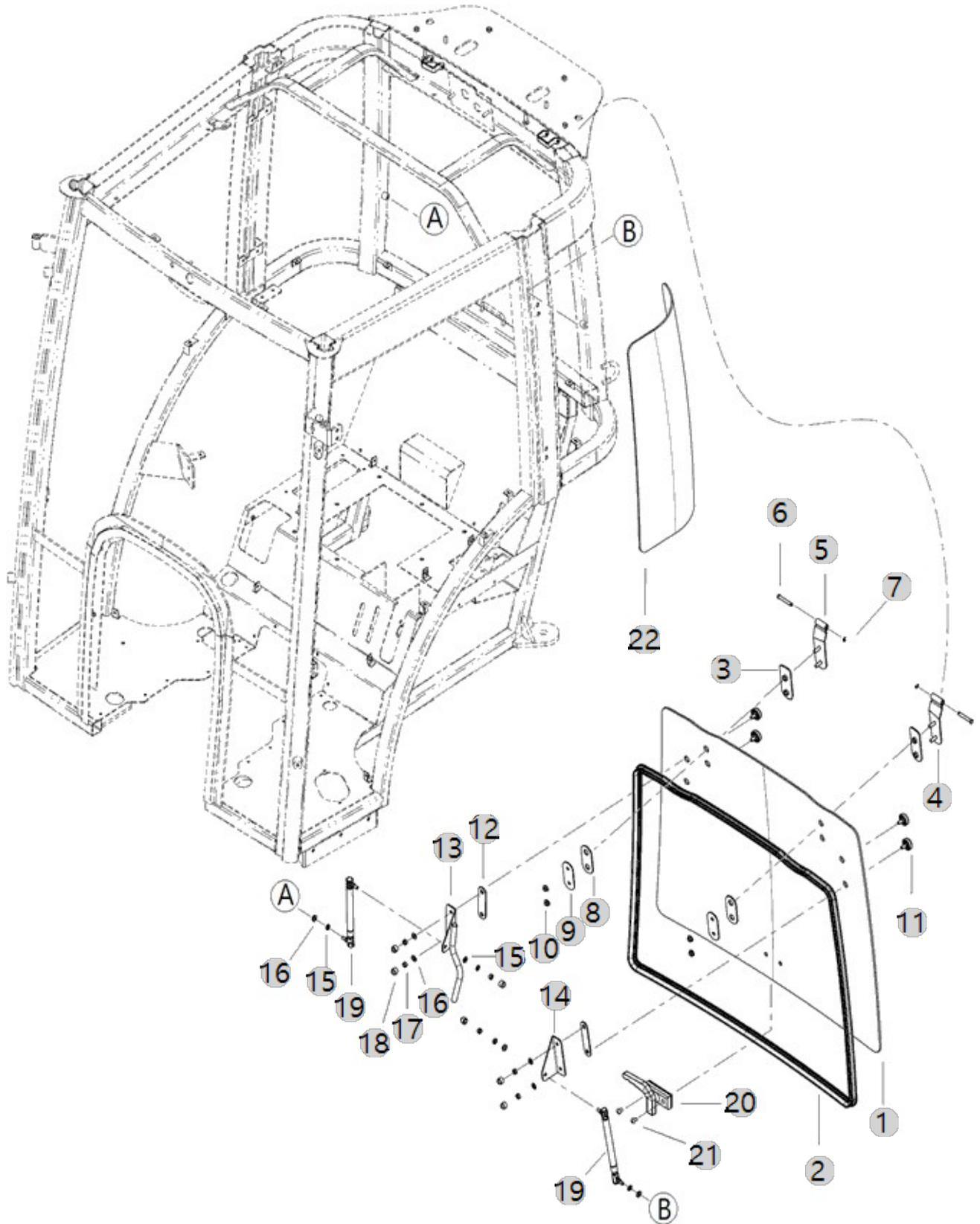

G02131

ROOF/OUTER

Year/Month

6225C(EU)(AC02123)

2022-12-19

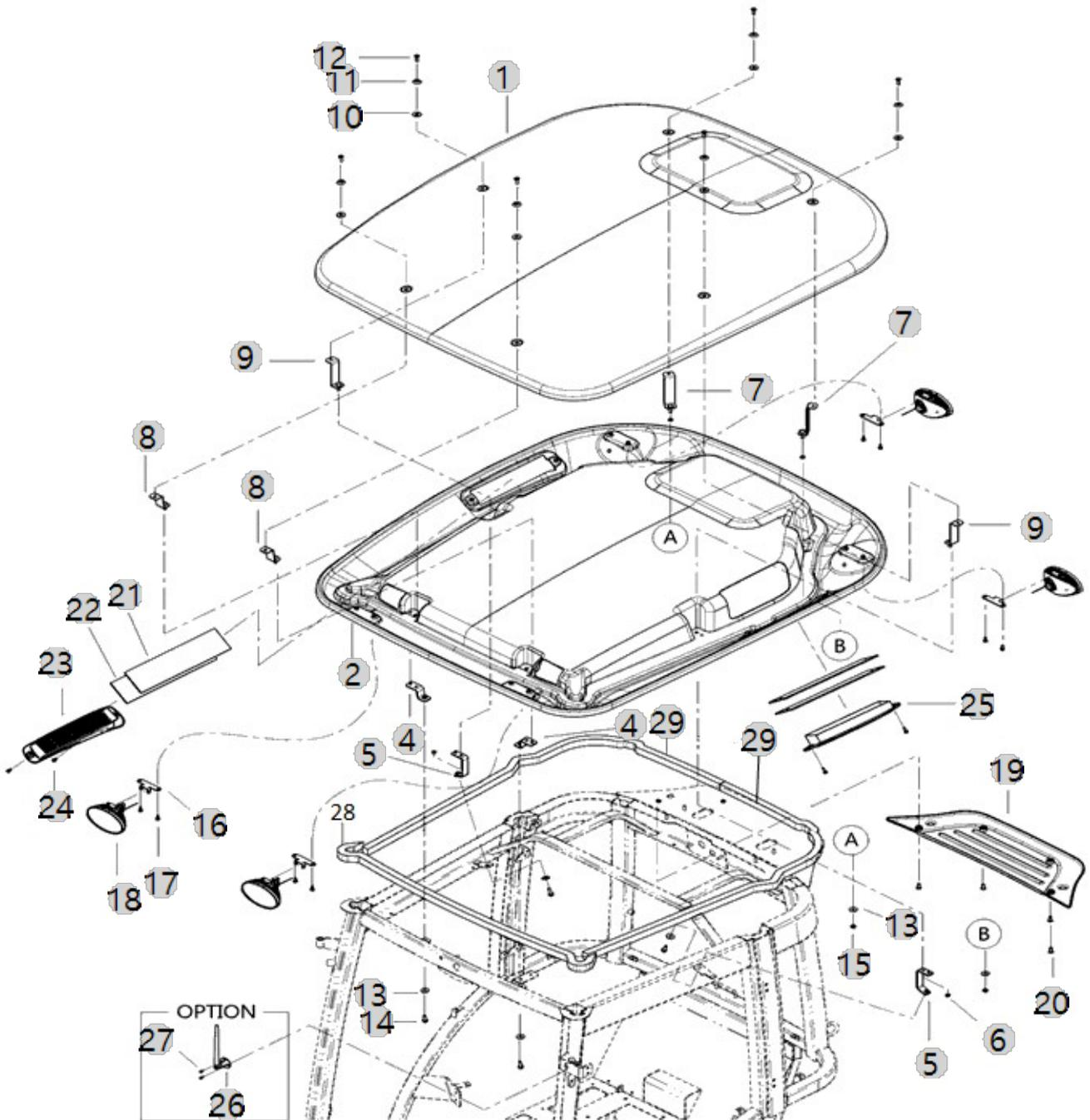

G02132

ROOF/INNER

Year/Month

6225C(EU)(AC02123)

2022-12-19

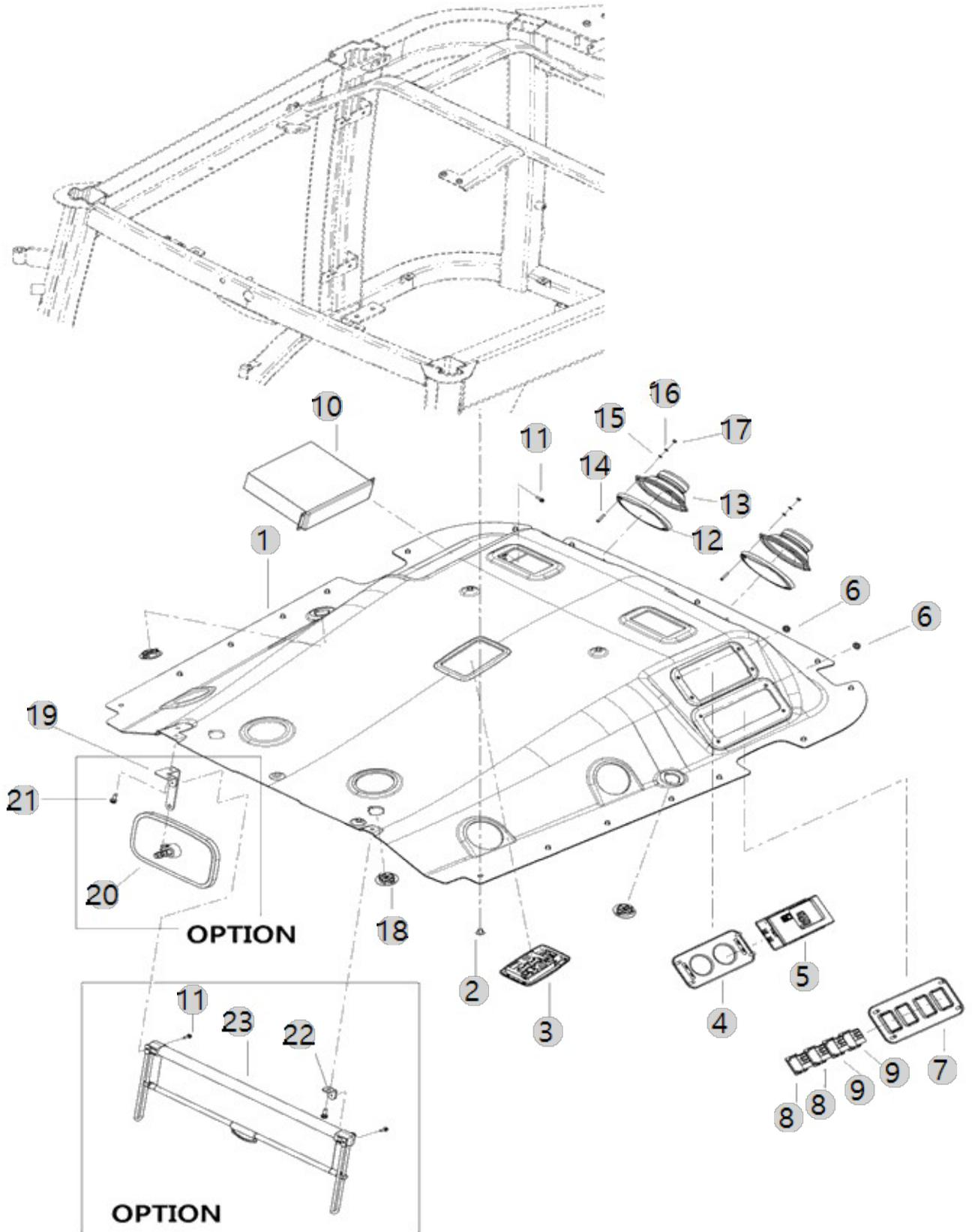

G02140

DRIVER'S SEAT

Year/Month

6225C(EU)(AC02123)

2022-12-19

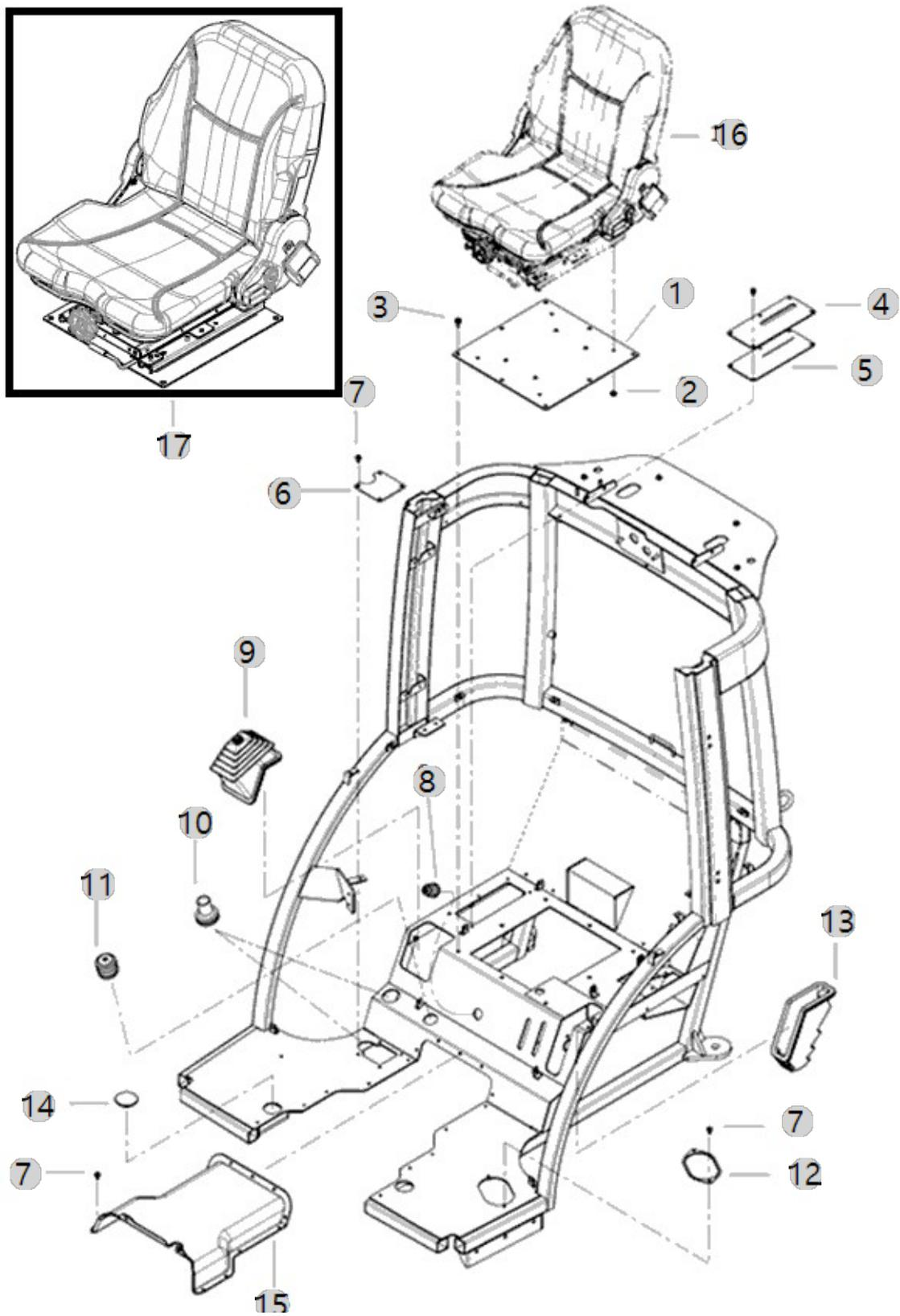

G02150

FLOOR MAT

Year/Month

6225C(EU)(AC02123)

2022-12-19

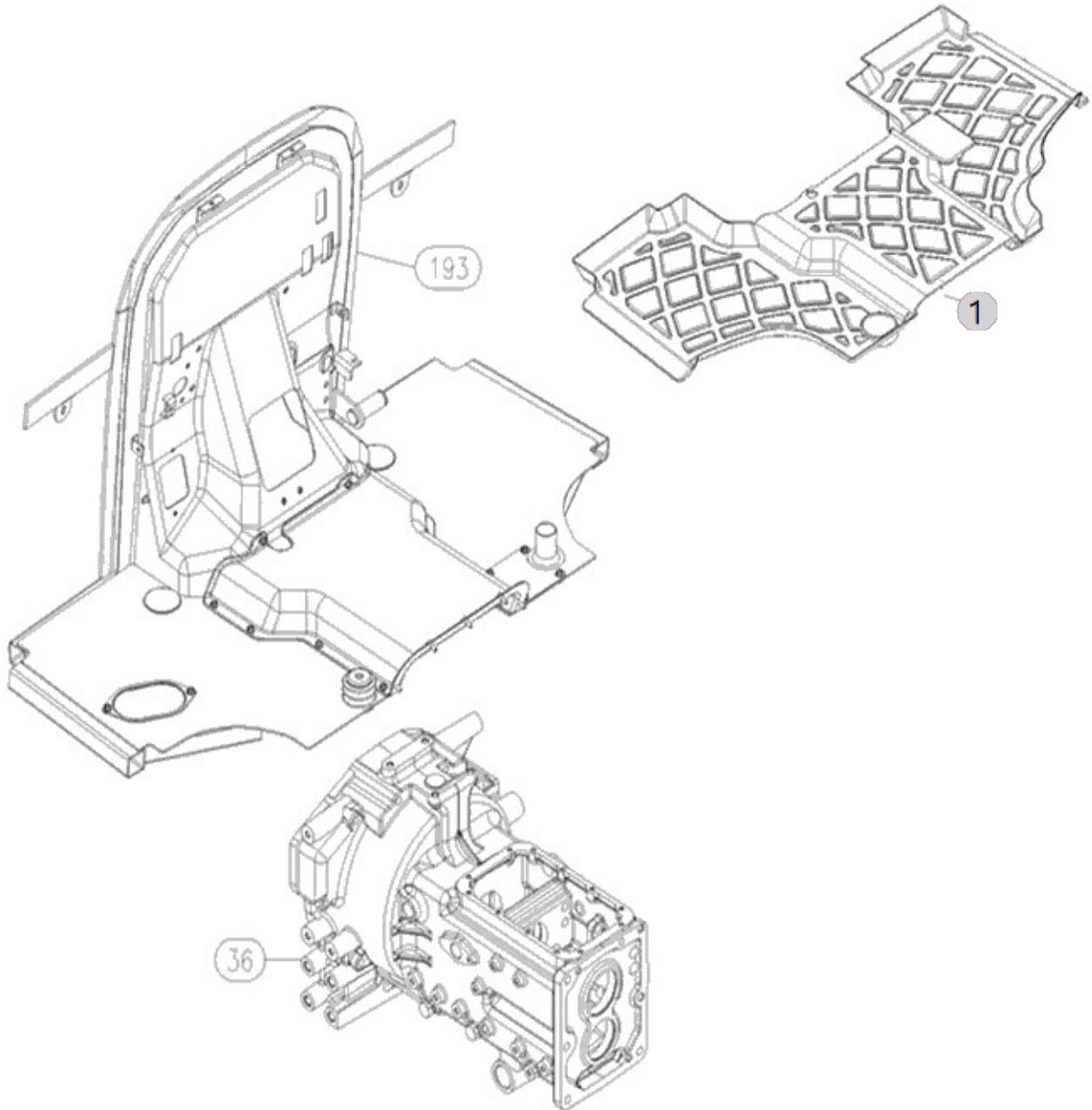

G02181

FENDER COVER/LH

Year/Month

6225C(EU)(AC02123)

2022-12-19

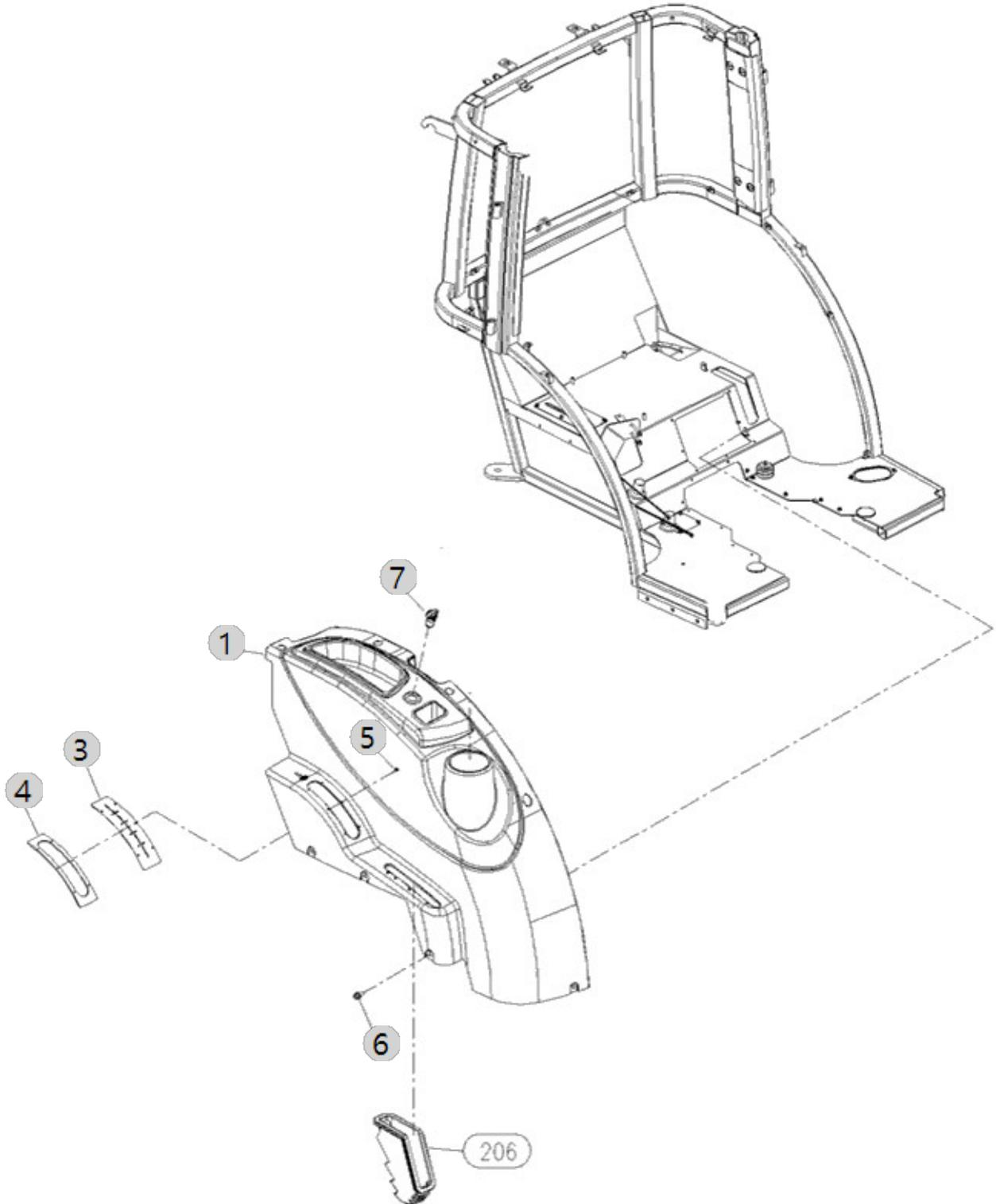

G02182

FENDER COVER/RH

Year/Month

6225C(EU)(AC02123)

2022-12-19

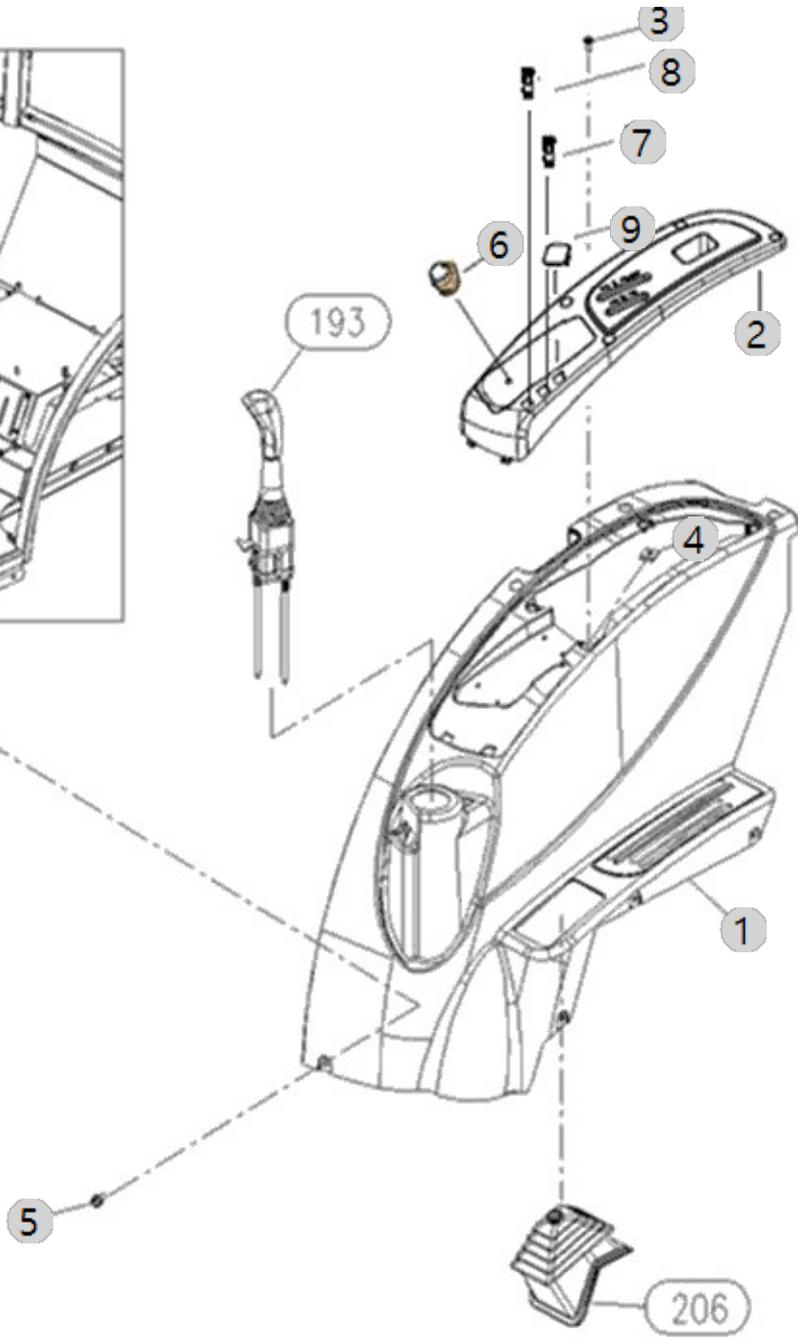
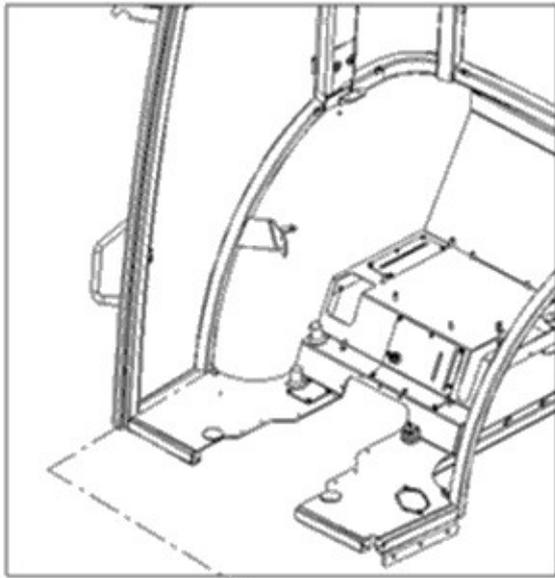

G02190

FENDER ASS'Y

Year/Month

6225C(EU)(AC02123)

2022-12-19

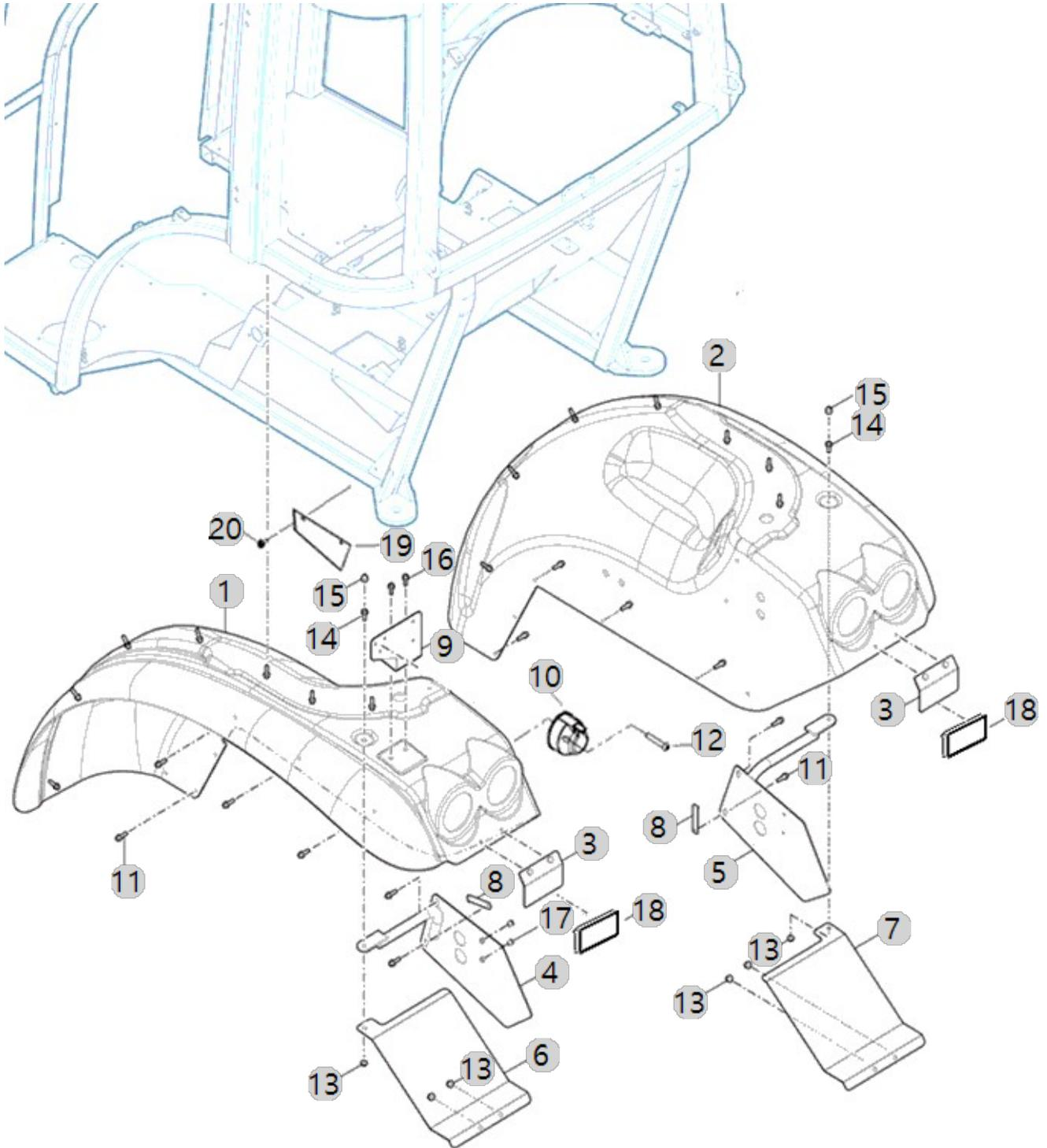

G03010

AIR CONDITIONER

Year/Month

6225C(EU)(AC02123)

2022-12-19

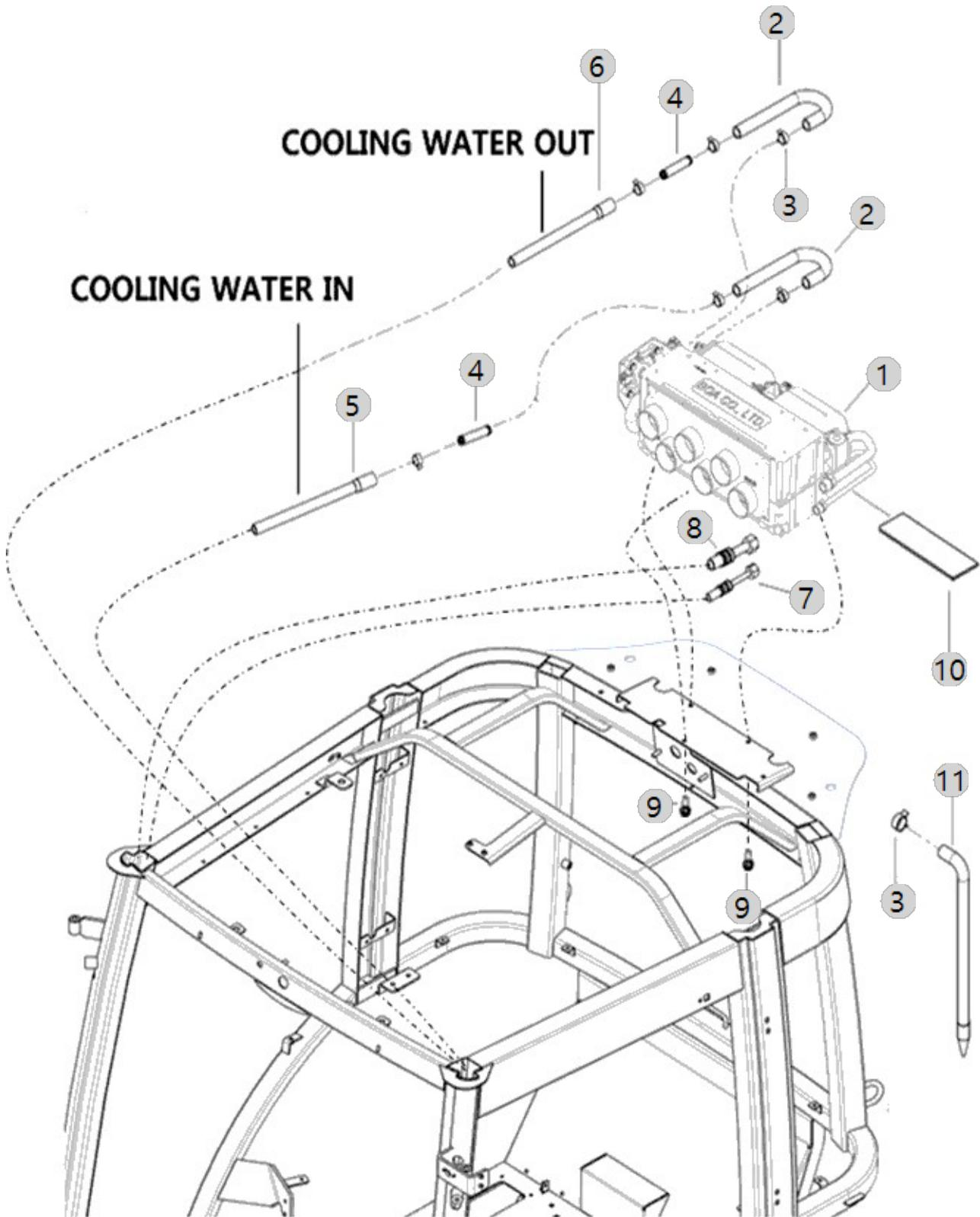

G03020

A/C DUCT

Year/Month

6225C(EU)(AC02123)

2022-12-19

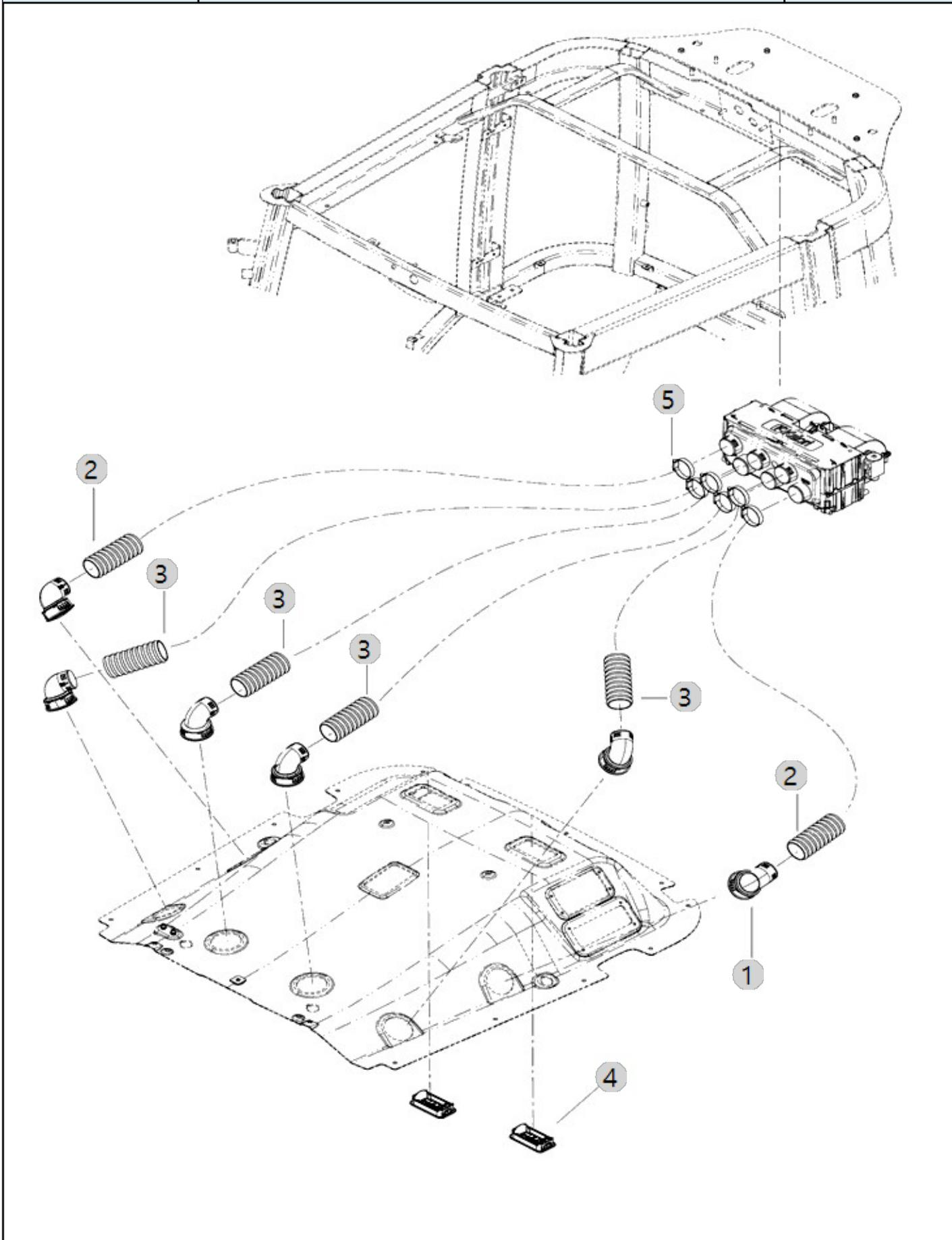

G03080

A.C HOSE/CONDENSER HOSE

Year/Month

6225C(EU)(AC02123)

2022-12-19

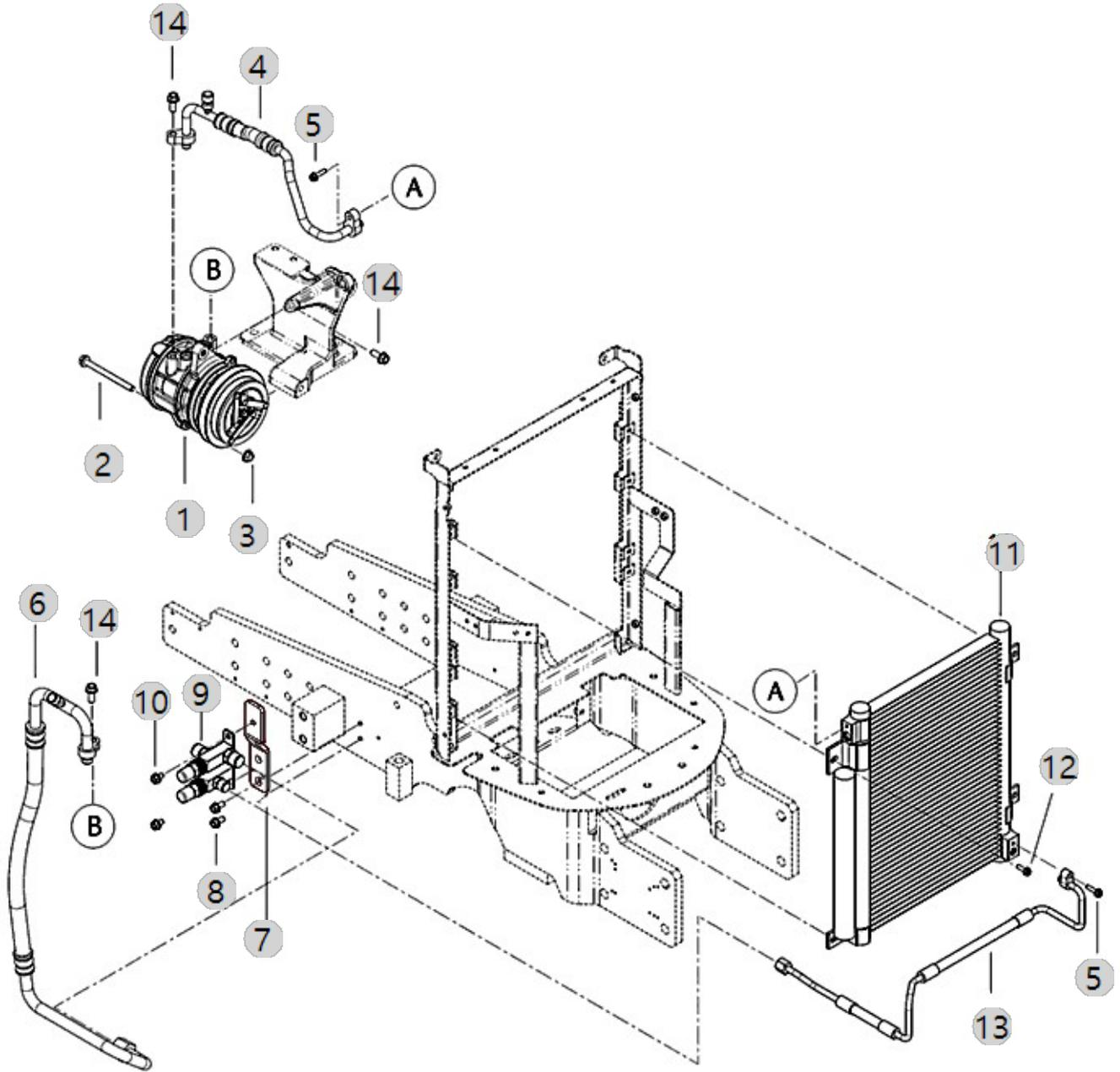

G03091

COMPRESSOR

Year/Month

6225C(EU)(AC02123)

2022-12-19

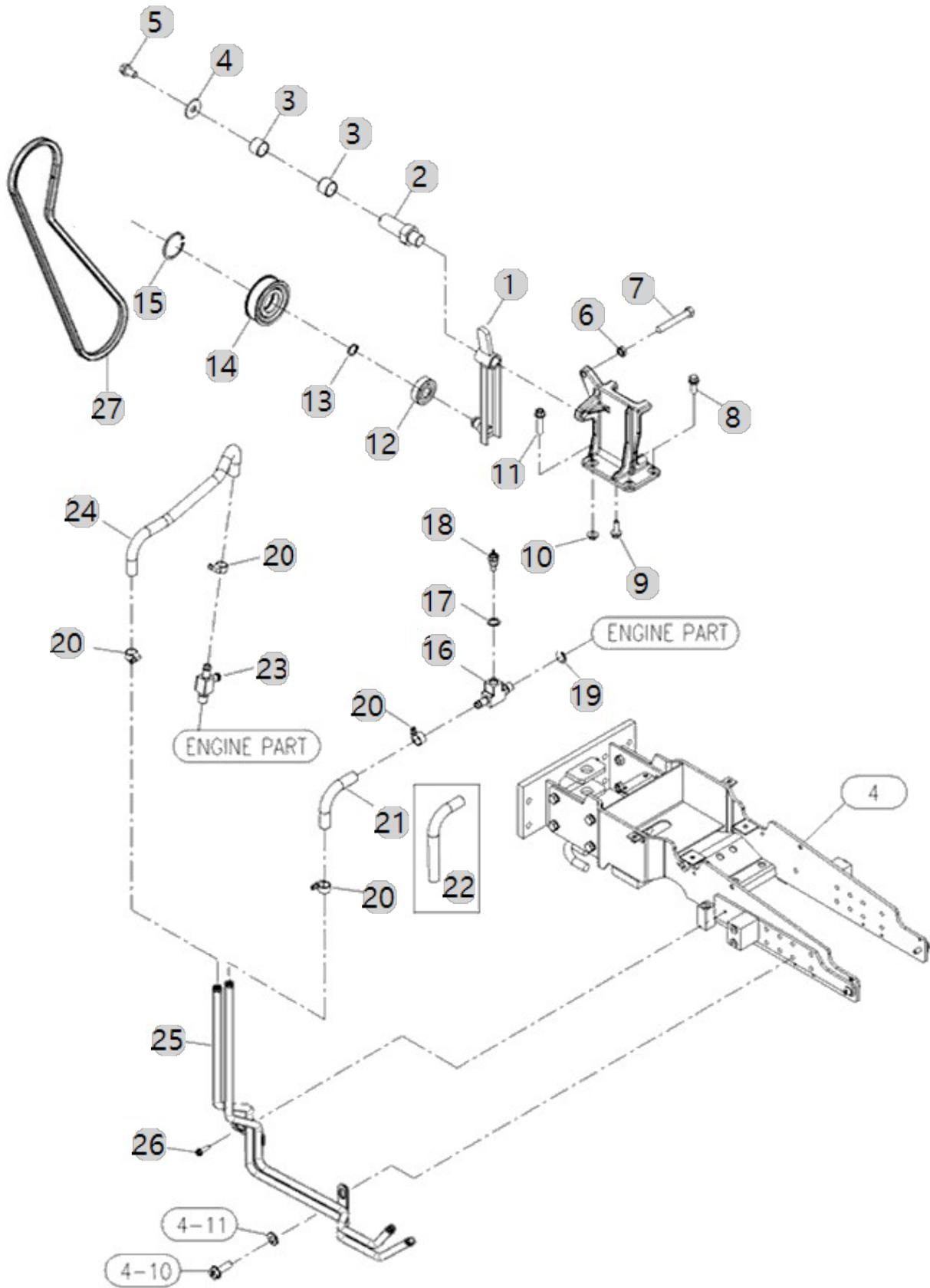

G05020

TOP LINK

Year/Month

6225C(EU)(AC02123)

2022-12-19

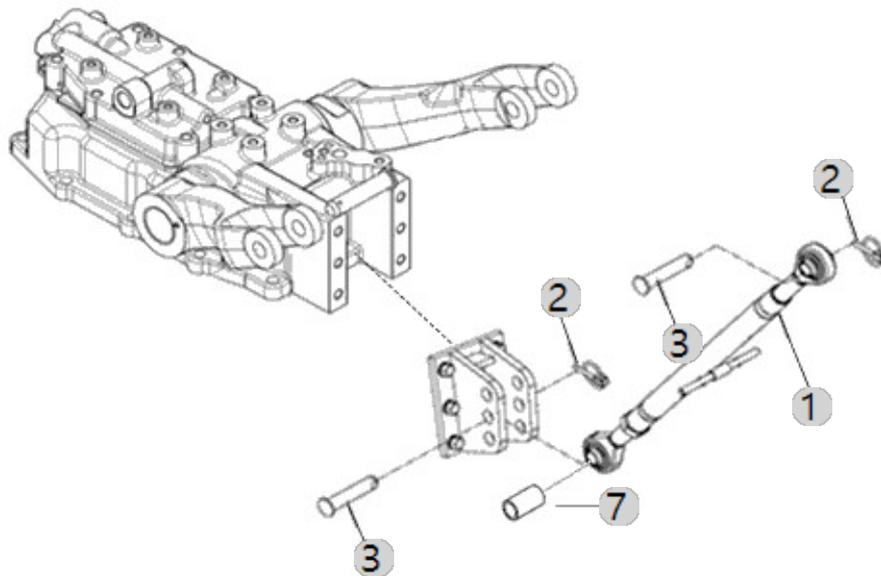
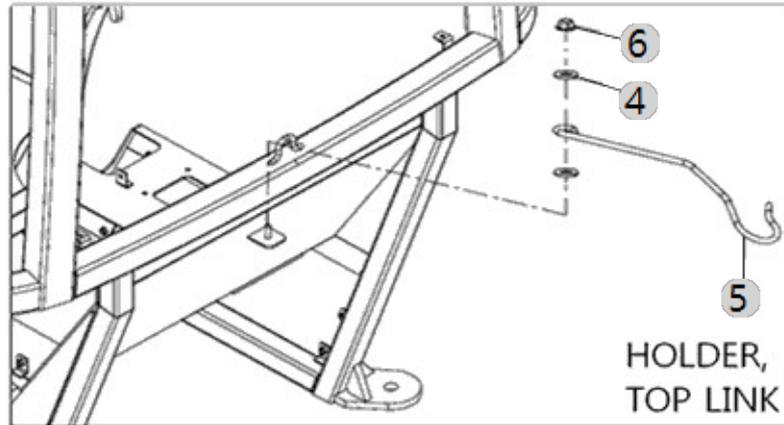

G05030

LOWER LINK

Year/Month

6225C(EU)(AC02123)

2022-12-19

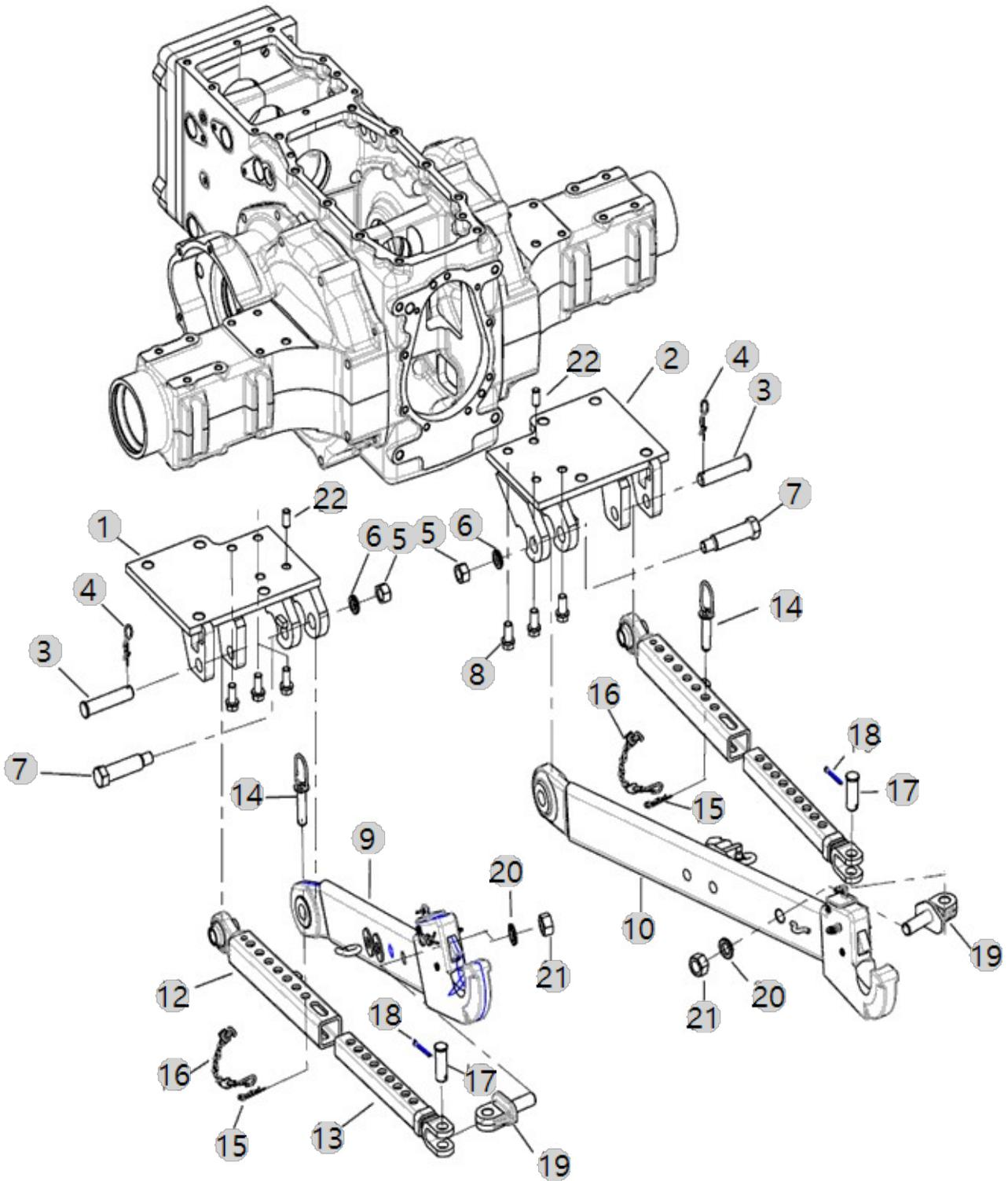

G05050

LIFT LINK/LH,RH

Year/Month

6225C(EU)(AC02123)

2022-12-19

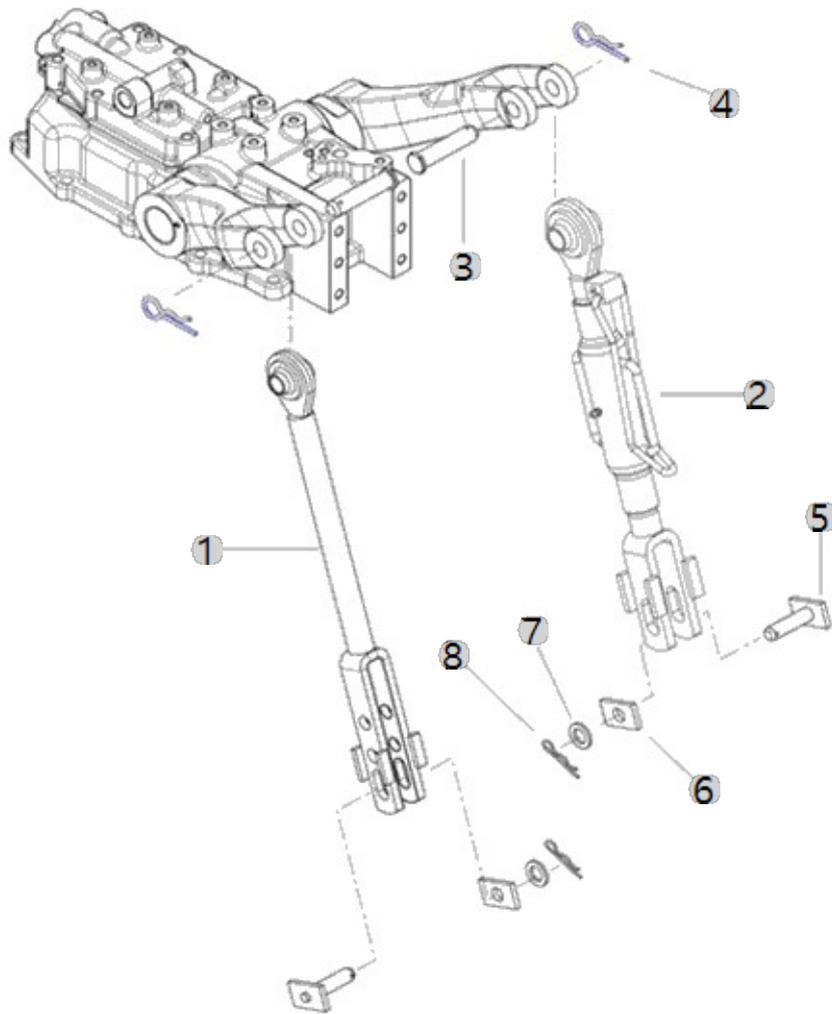

G05070

DRAWBAR

Year/Month

6225C(EU)(AC02123)

2022-12-19

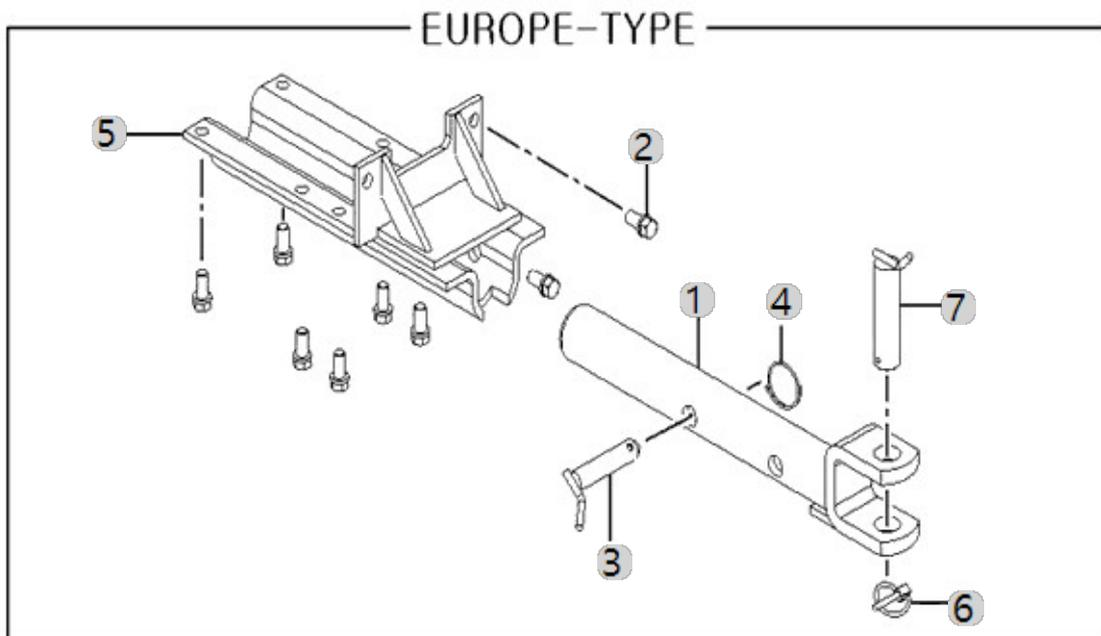

H01030

6225C(EU)(AC02123)

BATTERY

Year/Month

2022-12-19

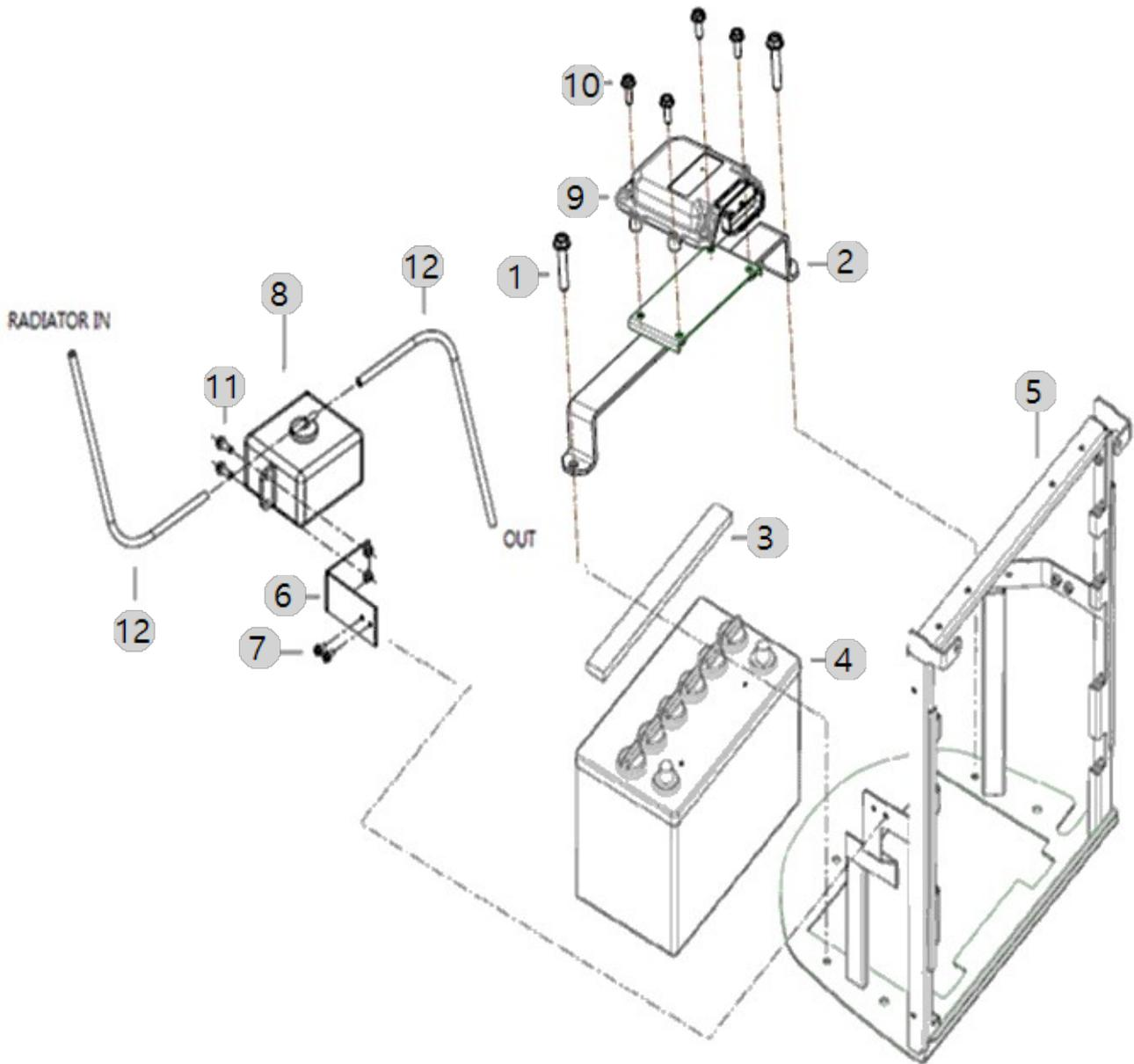

H02020

6225C(EU)(AC02123)

COMBINATION LAMP

Year/Month

2022-12-19

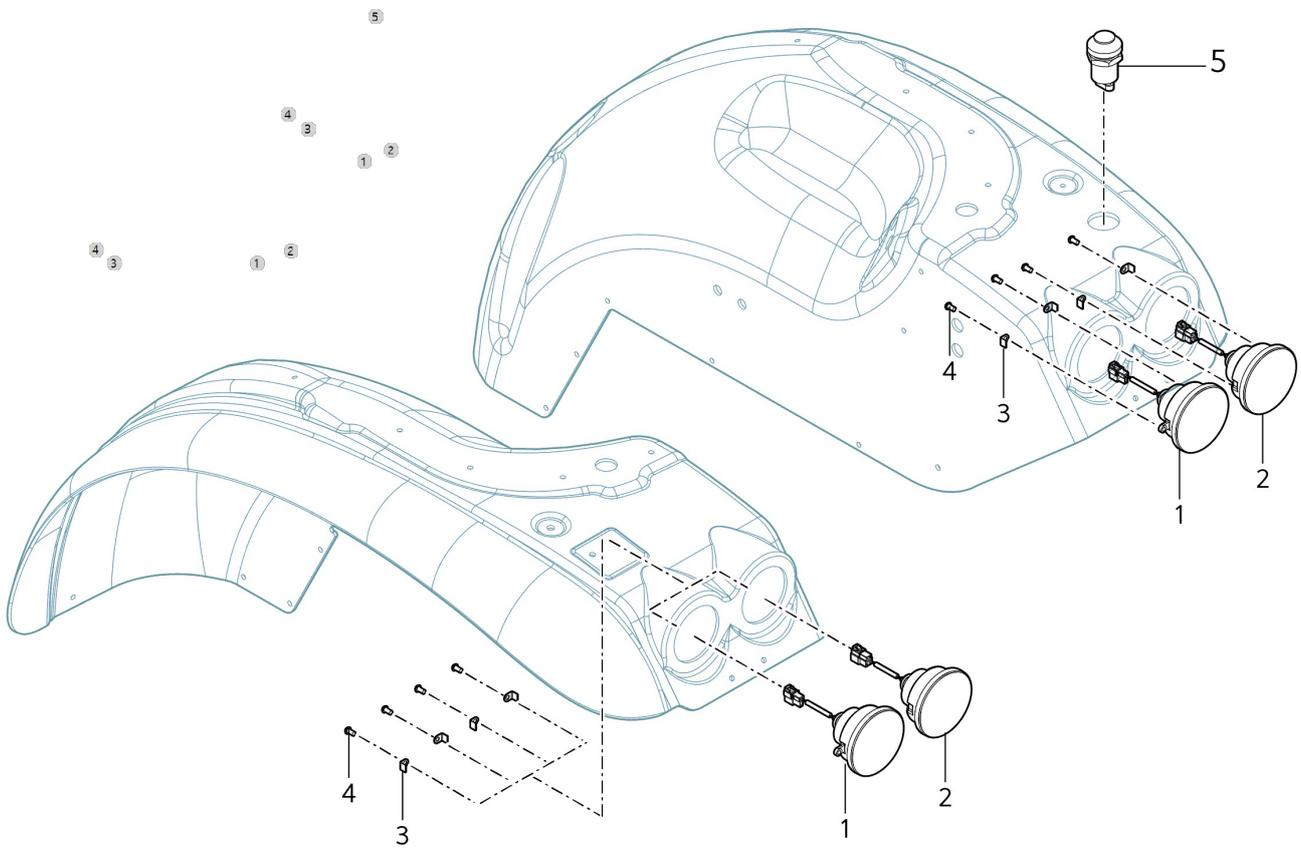

H04030

6225C(EU)(AC02123)

INSTRUMENT PANEL

Year/Month

2022-12-19

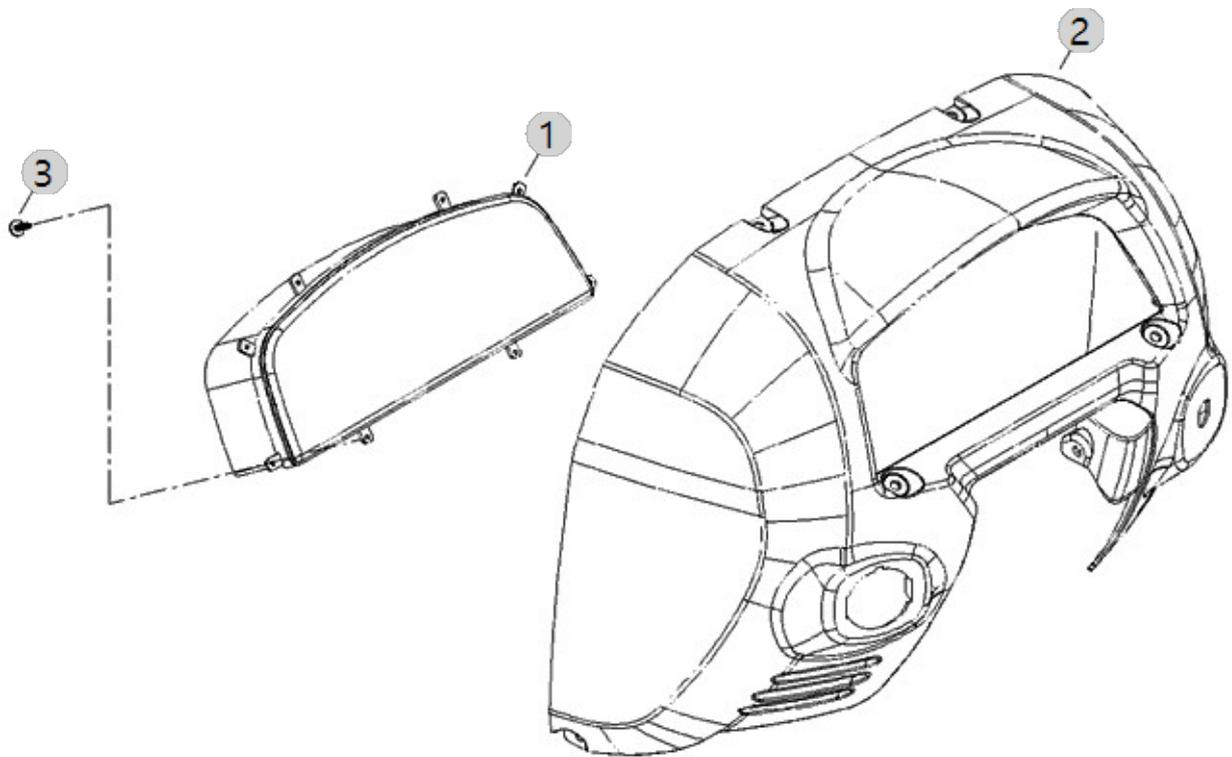

H04050

SWITCH

Year/Month

6225C(EU)(AC02123)

2022-12-19

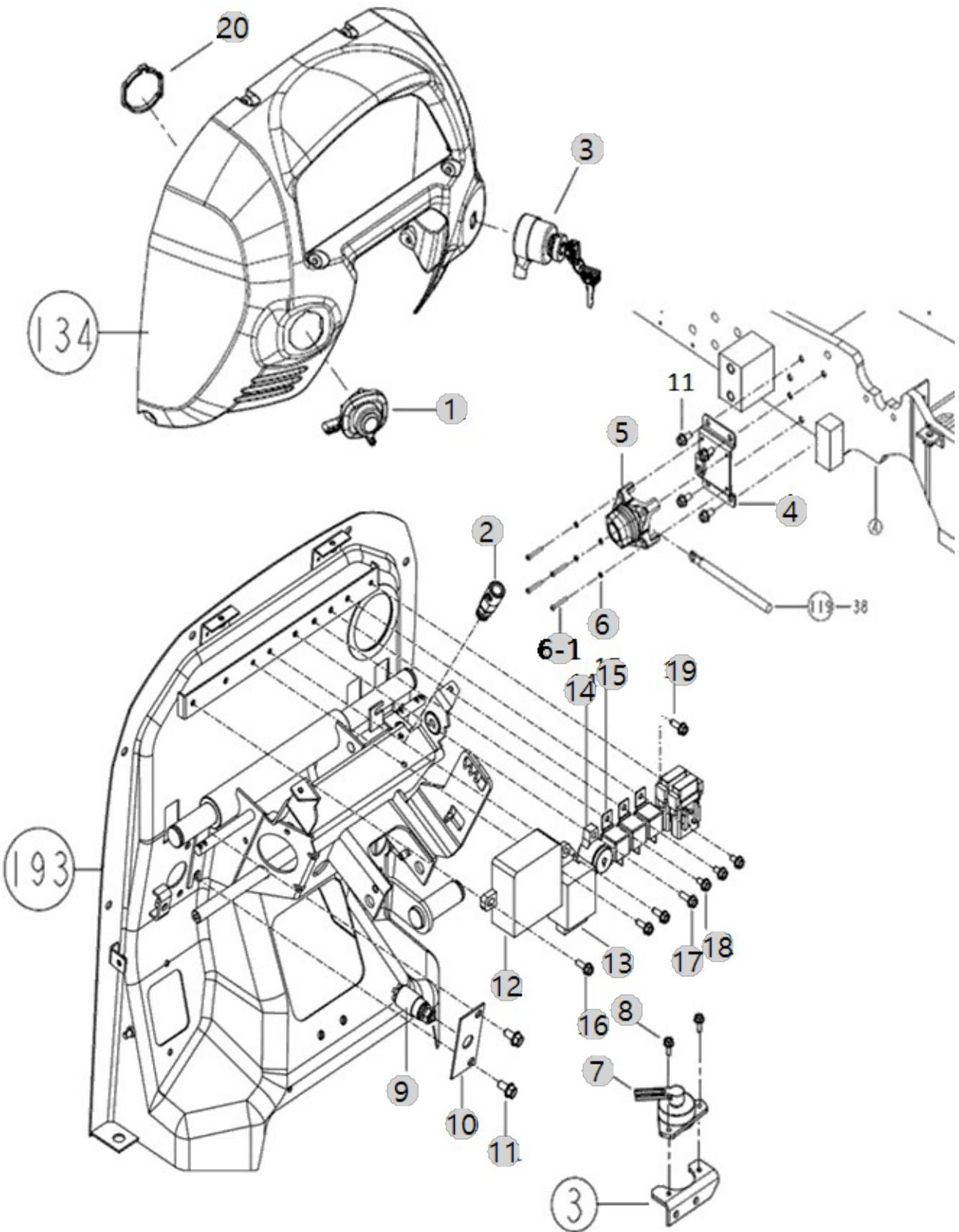

H04090

HORN

Year/Month

6225C(EU)(AC02123)

2022-12-19

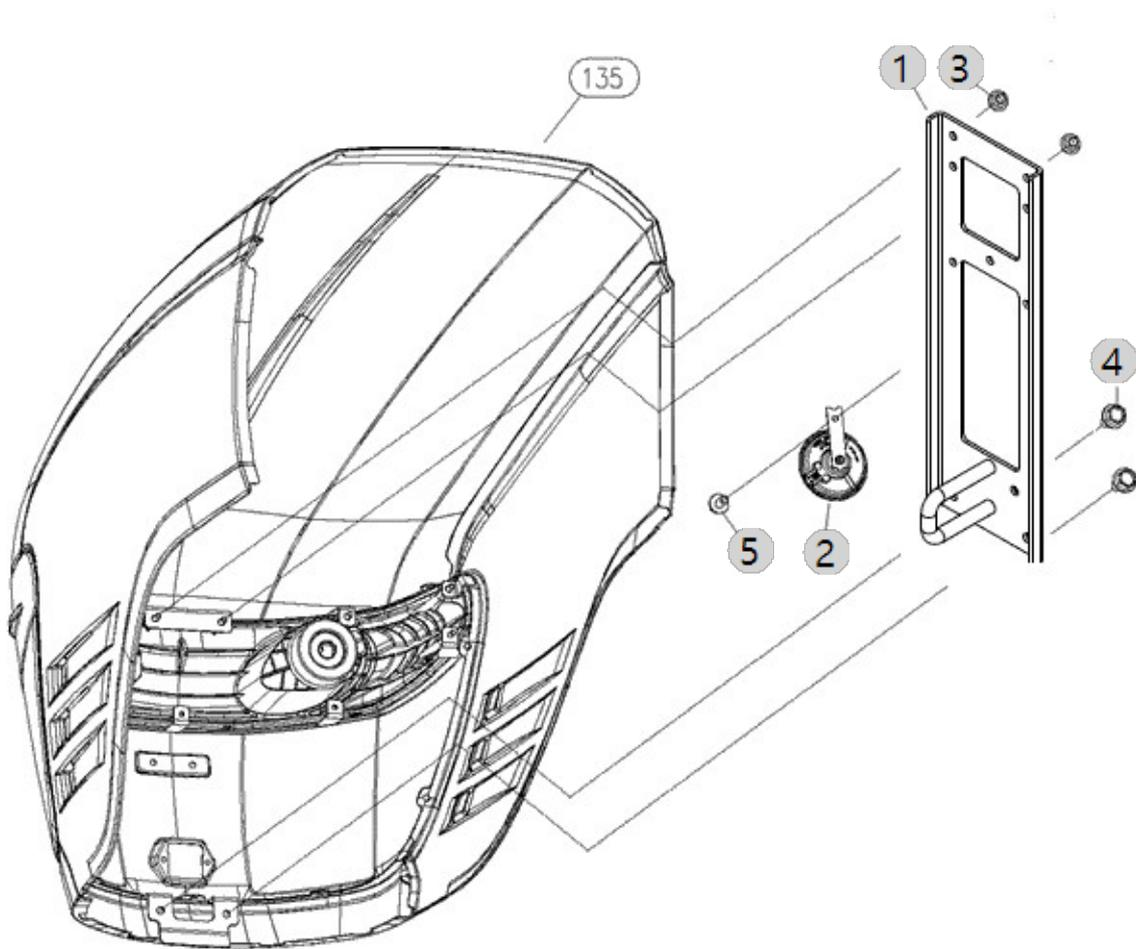

H05040

6225C(EU)(AC02123)

WASHER LIQUID TANK

Year/Month

2022-12-19

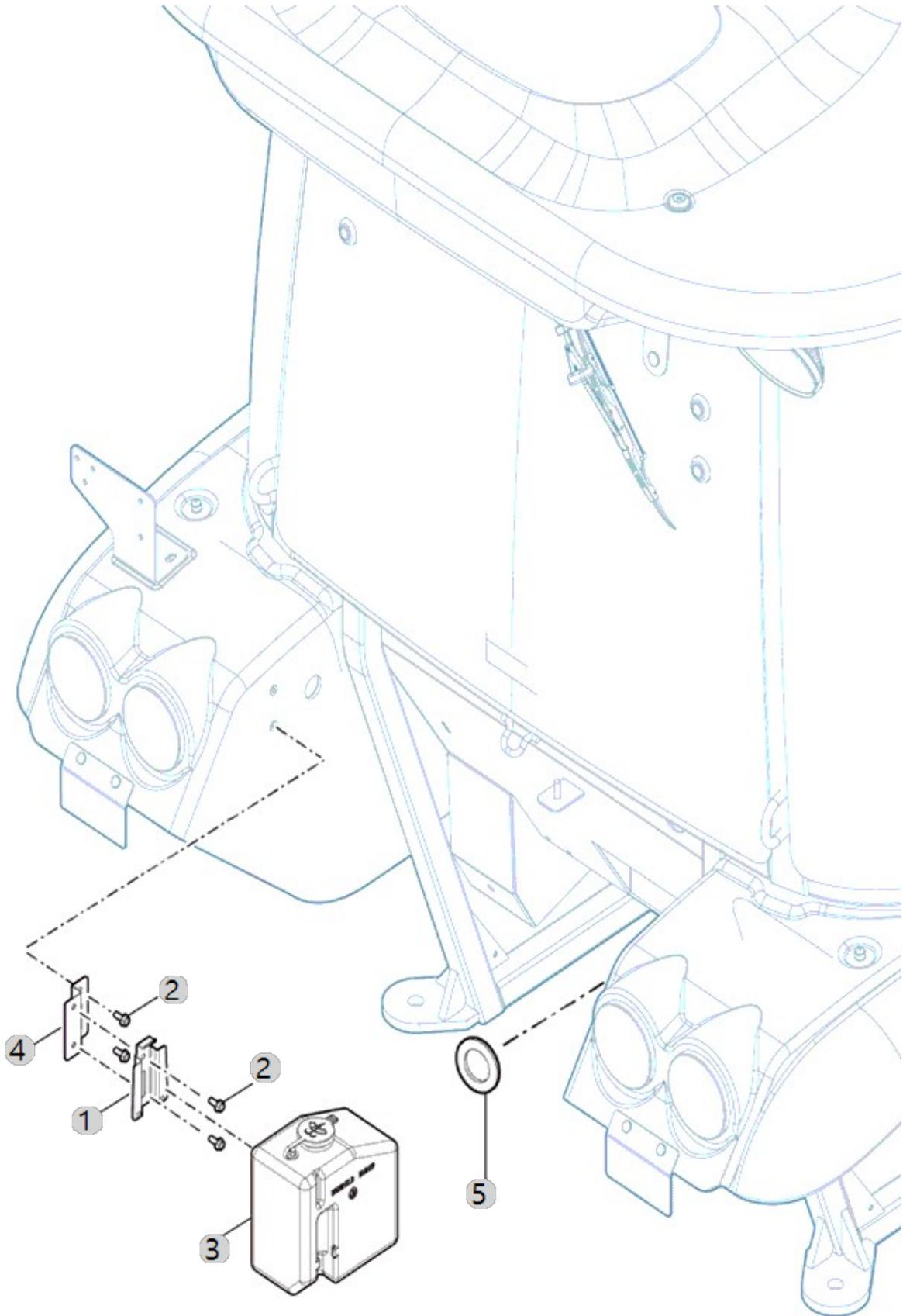

I01010

6225C(EU)(AC02123)

FRONT WEIGHT

Year/Month

2022-12-19

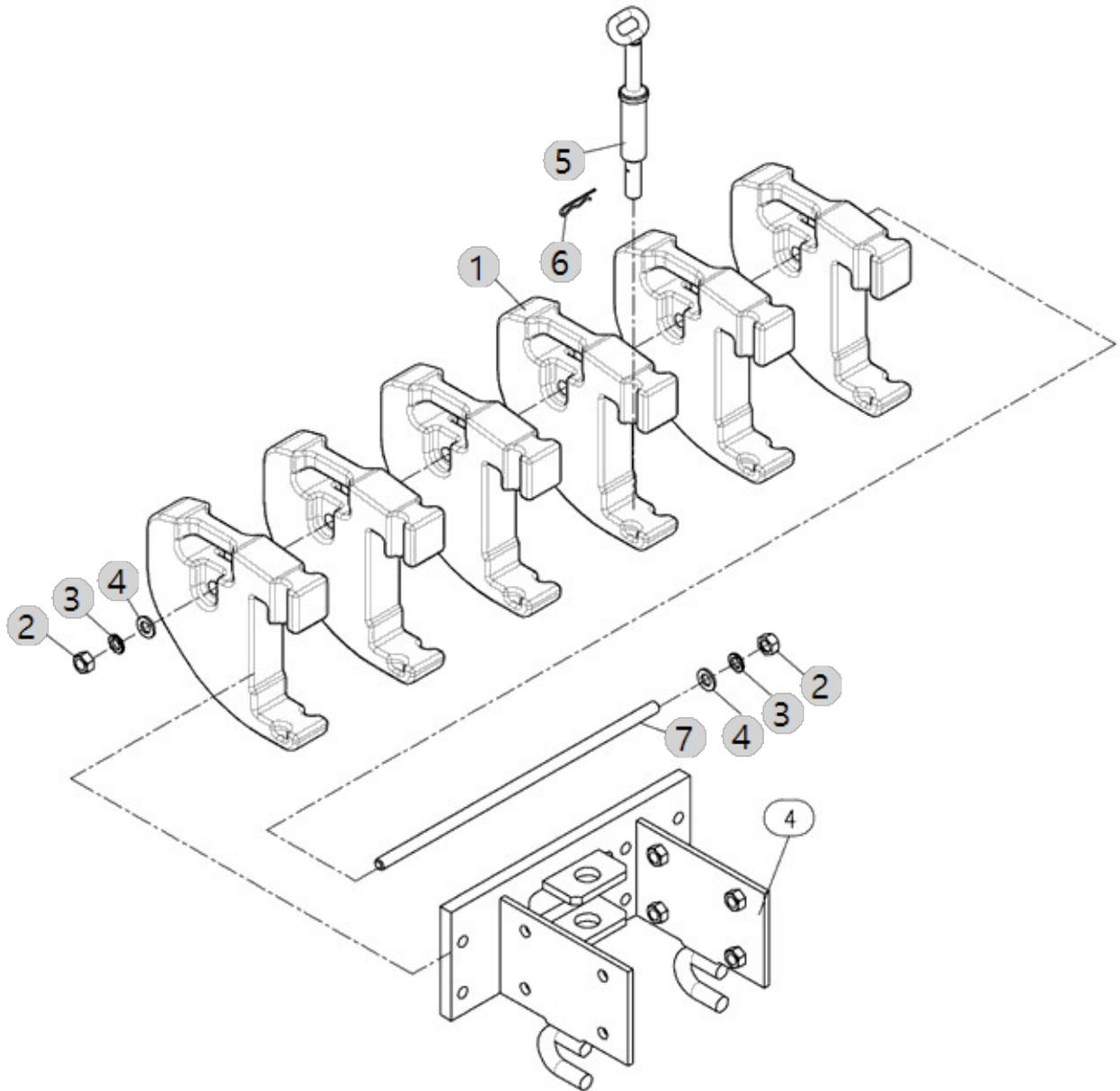

I03000

6225C(EU)(AC02123)

NAME PLATE

Year/Month

2022-12-19

5025C -1-1
5825C -1-2
6225C -1-3

TYM - 14

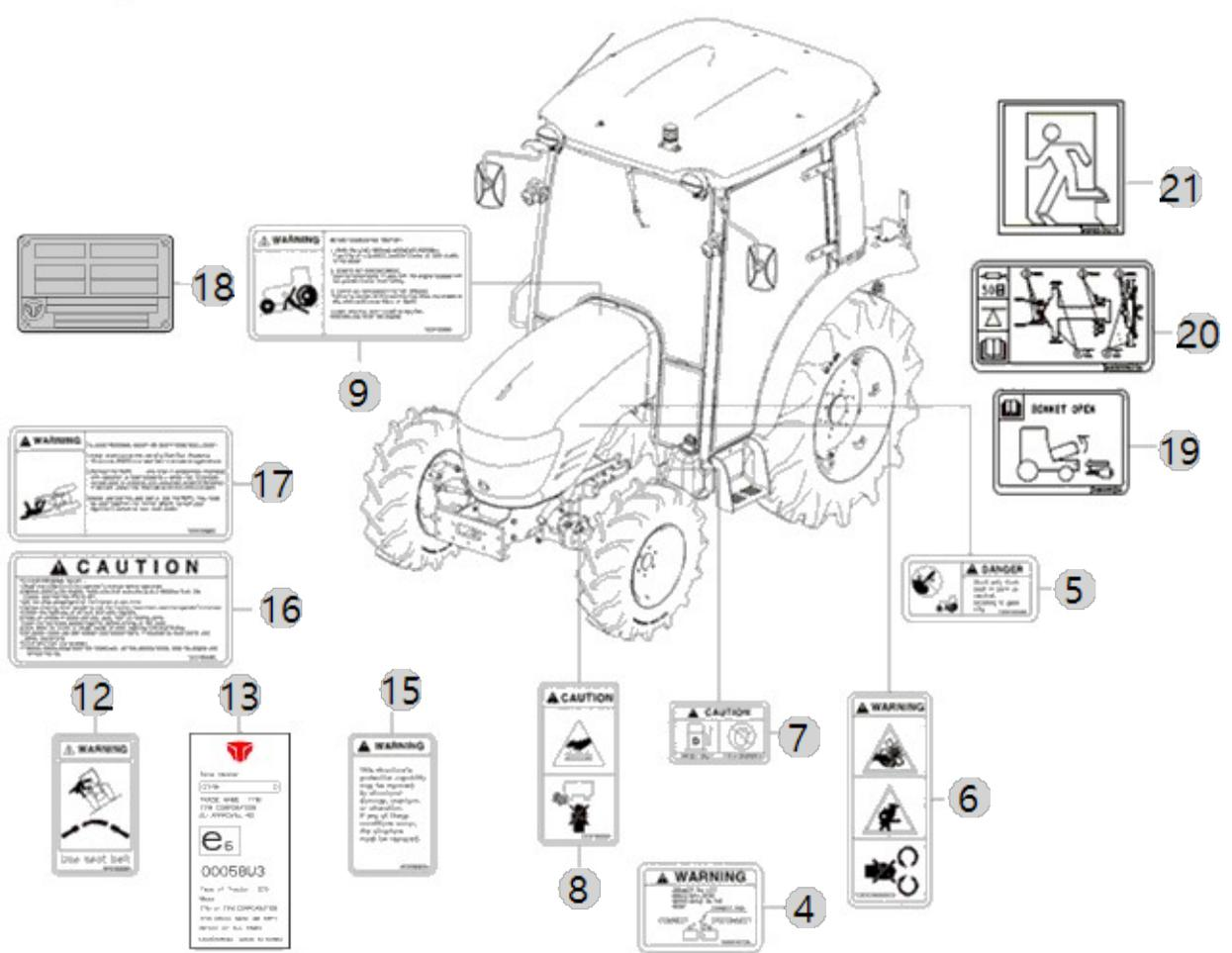
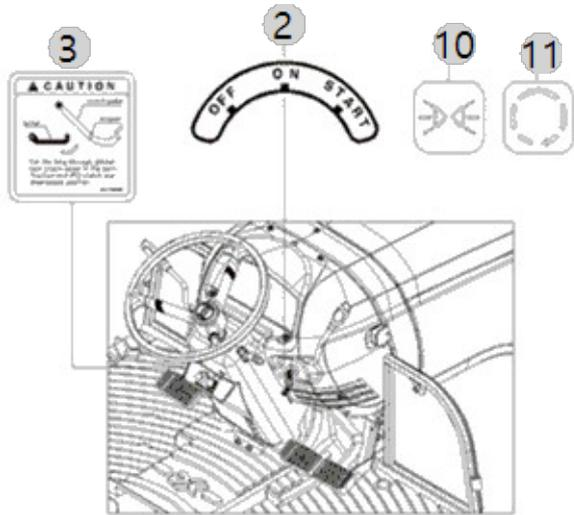

I03030

6225C(EU)(AC02123)

NAME PLATE

Year/Month

2022-12-19

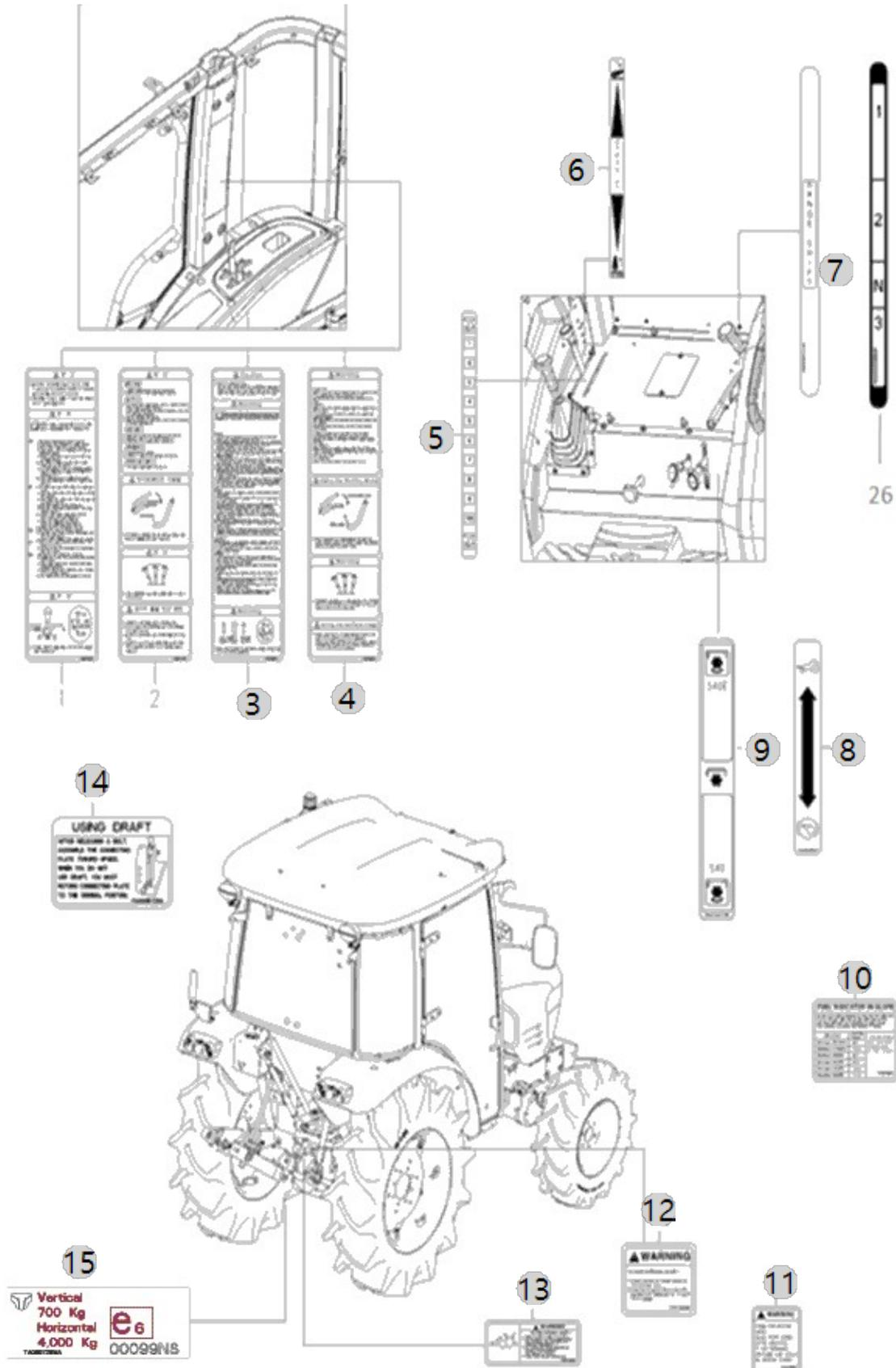

I05010

6225C(EU)(AC02123)

FRONT WHEEL&TIRE

Year/Month

2022-12-19

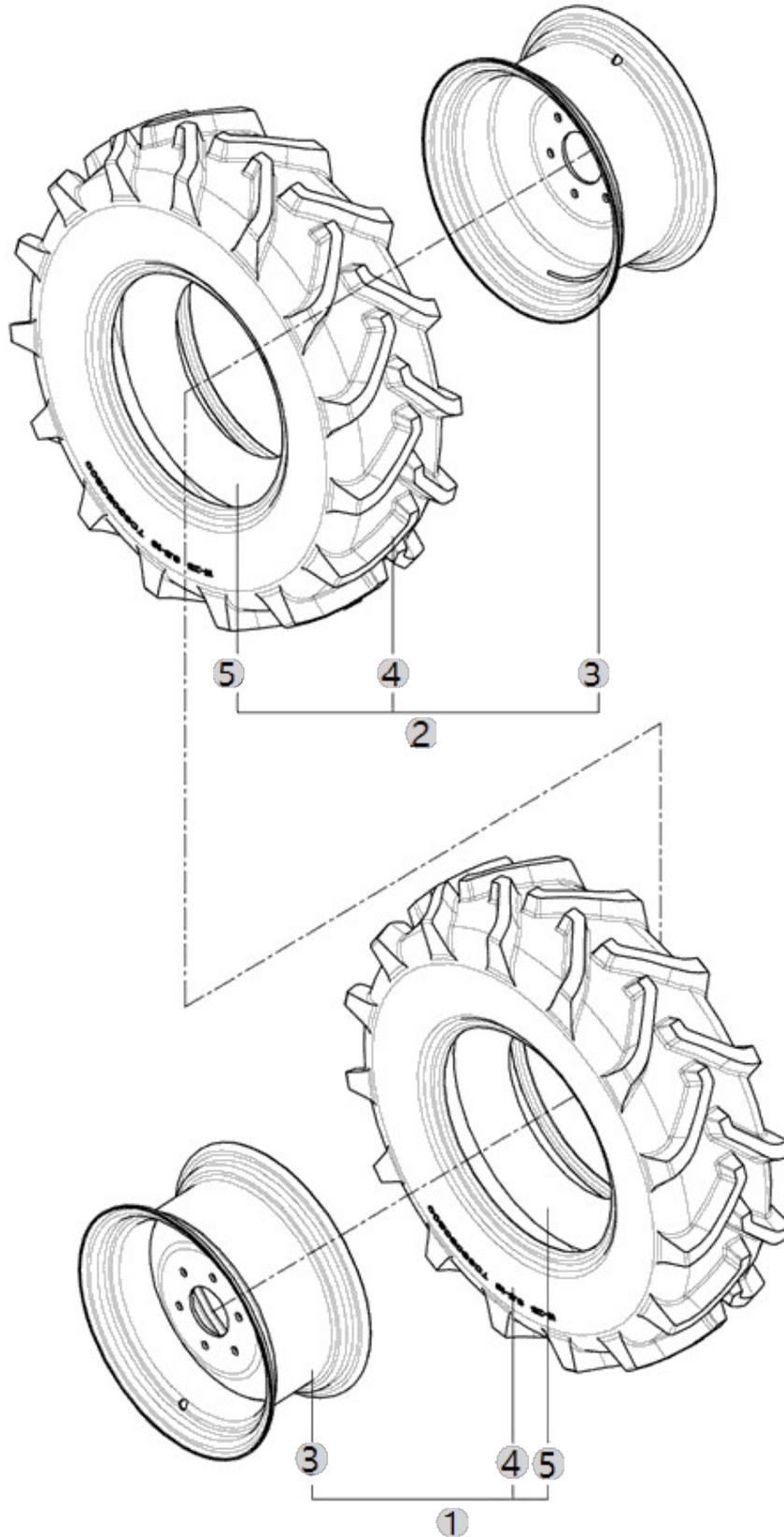

I05020

REAR WHEEL&TIRE ASSY

Year/Month

6225C(EU)(AC02123)

2022-12-19

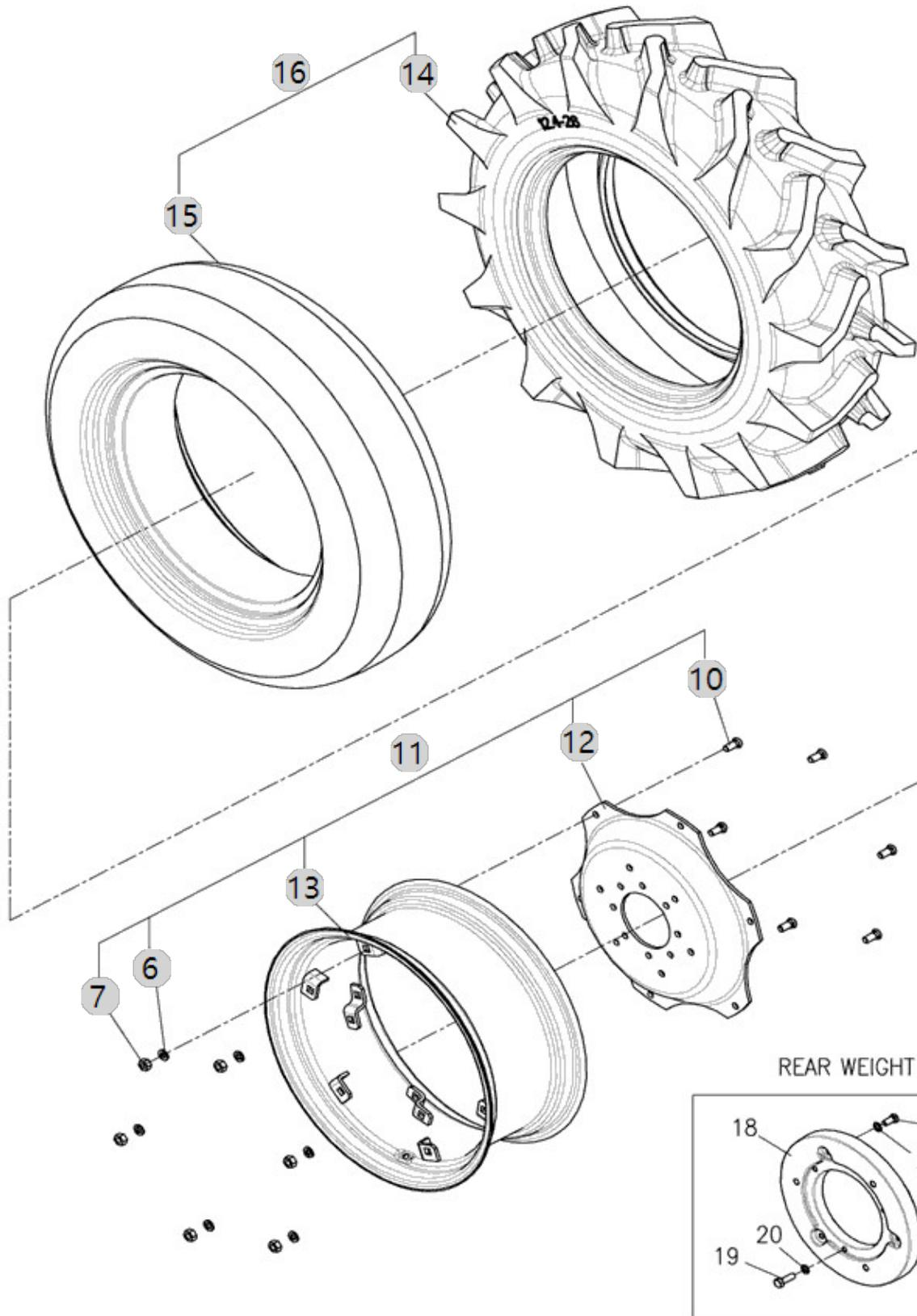

I07010

6225C(EU)(AC02123)

SPARE TOOLS

Year/Month

2022-12-19

