

OPERATOR'S MANUAL  
FOR BACKHOE  
(BH250 MODEL)

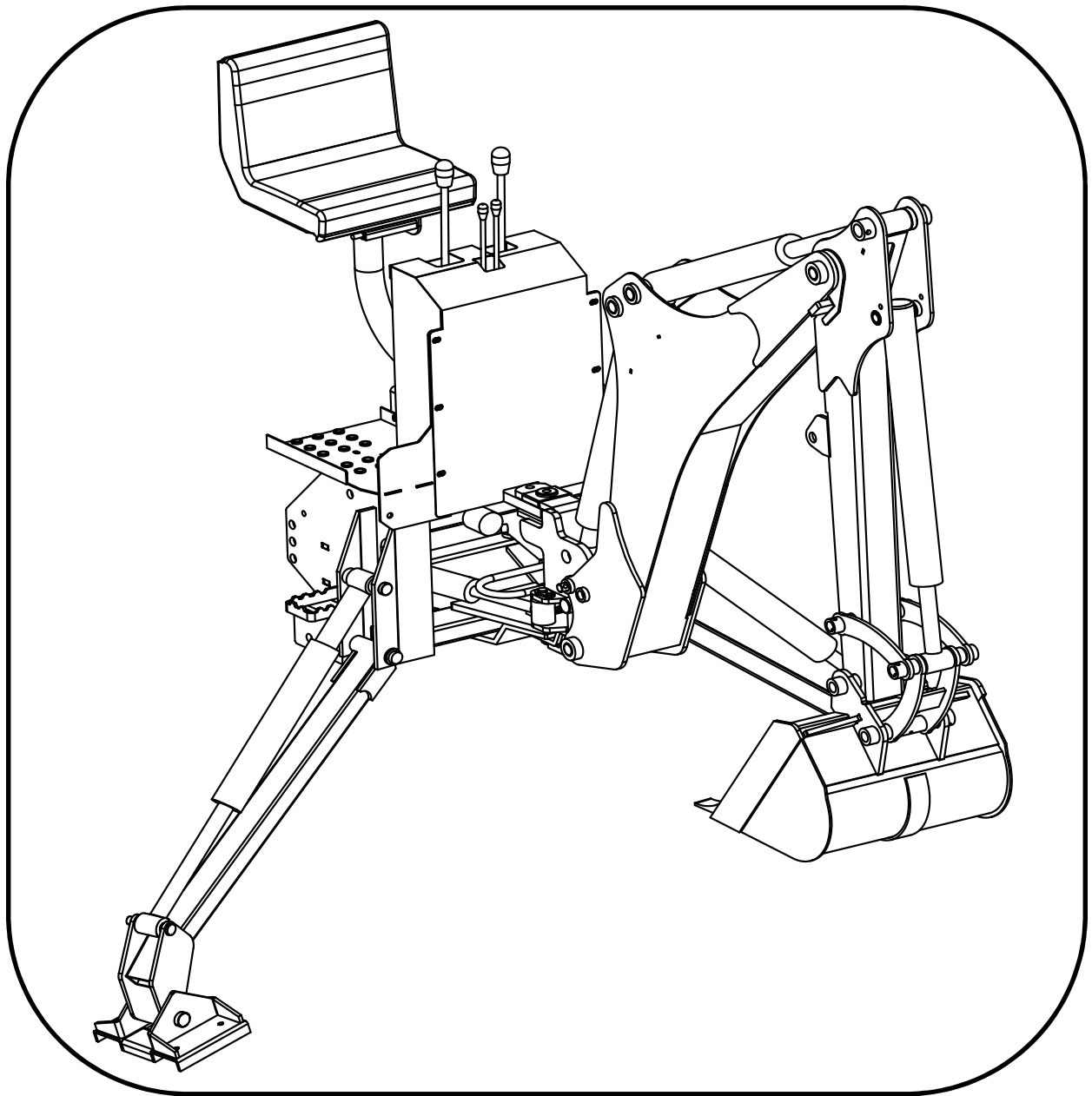

## Limited Warranty

Except for the Excluded Products as described below, all new products are warranted to be free from defects in material and/or workmanship during the Warranty period, in accordance with and subject to the terms and conditions of this limited Warranty.

1. Excluded products. The following products are excluded from this Limited Warranty:

- (a) Any cable, parts that engages with the ground(i.e. sprockets),digging chain, bearing, teeth, tamping and/or demolition head, blade cutting edge, pilot bit, auger teeth and broom brush that either constitutes or is part of a product.
- (b) Any product, merchandise or component that, in the opinion of **TYM** has been(1)missed;(2) modified in any unauthorized manner;(3) altered;(4) damaged;(5) involved in an accident; or(6) repaired using parts not obtained through **TYM co.,LTD.**

2. Warranty period. The Limited Warranty is provided only to those defect that occur during the warranty Period, which is the period that begins on the first to occur of;(1) the date of initial purchase by an end –user,(2) the date the product is first leased or rented, or(3) the date that is six(6) months after the date of shipment by **TYM company** as evidenced by the invoiced shipmentdate(the 'commencement date')and ends on the date that is twelve(12) months after the commencement Date.

3. Terms and conditions of Limited Warranty. The following terms and conditions apply to the Limited Warranty hereby provided:

- (a) Option to repair or Replace. **TYM company** shall have the option to repair or replace the product.
- (b) Timely repair and Notice. In order to obtain the Limited Warranty,(1) the product must be repaired with thirty(30) days from the date of failure, and(2) a claim under the warranty must be submitted to **TYM company** in writing within thirty(30) days from the date of repair.
- (c) Return of Defective part or product. If requested by **TYM company** , the alleged defective part or product shall be shipped to **TYM company** at its manufacturing facility or other location specified by **TYM company** , with freight PRE-PAID by the claimant, to allow **TYM company** to inspect the part or product.

Claims that fail to comply with any of the above terms and conditions shall be denied.

## LIMITATIONS AND EXCLUSIONS.

THIS LIMITED WARRANTY IN IN LIEU OF ALL OTHER WARRANTIES,EXPRESS OR IMPLIED,INCLUDING WITHOUT LIMITATION THE WARRANTIES OF MERCHANTABILITY,FITNESS FOR PARTICULAR PURPOSE AND ANY WARRANTY BASED ON A COURSE OF DEALING OR USAGE OF TRADE.

IN NO EVENT SHALL **TYM COMPANY** BE LIAVLE FOR CONSEQUENTIAL OR SPECIAL DAMAGES.

IN NO EVENT SHALL **TYM COMPANY** BE LIABLE FOR ANY LOSS OR CLAIM IN AN AMOUNT IN EXCESS OF THE PURCHASE PRICE,OR AT THE OPTION OF **TYM COMPANY** , THE REPAIR OR REPLACEMENT,OF THE PARTICULAR PRODUCT ON WHICH ANY CLAIM OF LOSS OR DAMAGE IS BASED.THE LIMITATION OF LIABILITY APPLIES INRESPECTIVE OF WHETHER THE CLAIM IS BASED ON BREACH OF CONTRACT,BREACH OF WARRANTY,NEGLIGENCE OR OTHER CAUSE AND WHETHER THE ALLEGED IS DISCOVERABLE OR LATENT.

## TABLE OF CONTENTS

<b>PREFACE</b> -----	4
<b>SAFETY PRECAUTIONS</b> -----	6
<b>SAFETY DECALS</b> -----	10
<b>BACKHOE SPECIFICATIONS</b> -----	12
<b>INSTRUCTION</b> -----	14
<b>TRACTOR PREPARATION</b> -----	15
<b>BACKHOE OPERATION</b> -----	16
<b>BACKHOE REMOVAL</b> -----	19
<b>BACKHOE MOUNTING</b> -----	20
<b>LUBRICATION AND MAINTENANCE</b> -----	23
<b>TROUBLE SHOOTING</b> -----	25
<b>HYDRAULIC SYSTEM SCHEMATIC</b> -----	28
<b>TORQUE TIGHTENING CHART</b> -----	29
<b>PART ILLUSTRATIONS</b> -----	31

## PREFACE

### GENERAL COMMENTS

Congratulations on the purchase of your new **TYM BACKHOE** product! This product was carefully designed and manufactured to give you many years of dependable service. Only minor maintenance (such as cleaning and lubricating) is required to keep it in top working condition. Be sure to observe all maintenance procedures and safety precautions in this manual and on any safety decals located on the product and on any equipment on which the attachment is mounted.

This manual has been designed to help you do a better, safer job. Read this manual carefully and become familiar with its contents.

**WARNING**  Never let anyone operate this unit without reading the “Safety Precautions” and “operating Instructions” sections of manual. Always choose hard, level ground to park the vehicle on and set the brake so the unit cannot roll.

Unless noted otherwise, right and left sides are determined from the operator’s control positioning when facing the attachment.

**NOTE:** The illustrations and data used in this manual were current (according to the information available to us) at the time of printing, however, we reserve the right to redesign and change the attachment as may be necessary without notification

### BEFORE OPERATION

The primary responsibility for safety with this equipment falls to the operator. Make sure. The equipment is operated only by trained individuals that have read and understand this manual. If there is any portion of this manual or function you do not understand, contact your local authorized dealer or the manufacturer to obtain further assistance. Keep this manual available for reference. Provide the manual to any new owners and/or operators.

### SAFETY ALERT SYMBOL

Use only manufacturer replacement parts. Substitute parts may not meet the required standards. Record the model and serial number of your unit on the cover of this manual. The parts department needs this information to insure that you receive the correct parts.

### SOUND AND VIBRATION

Sound pressure levels and vibration data for this attachment are influenced by many different parameters: some items are listed below (not inclusive):



- Tractor type, age, condition, with or without cab enclosure and configuration.
- Operator training, behavior, stress level.
- Job site organization, working material condition, environment.

Based on the uncertainty of the tractor, operator and job site, it is not possible to get precise machine and operator sound pressure levels or vibration levels for this attachment.

## SAFETY STATEMENTS

### WARNING SIGNS IN THIS MANUAL

The following warning signs in this manual draw additional attention to items of importance for the safe and correct operation of the rotavator.

SIGN	MEANING OF THE SIGN
 <b>DANGER</b>	THIS SIGNAL WORD IS USED WHERE SERIOUS INJURY OR DEATH WILL RESULT IF THE INSTRUCTIONS ARE NOT FOLLOWED PROPERLY
 <b>WARNING</b>	THIS SIGNAL WORD IS USED WHERE SERIOUS INJURY OR DEATH COULD RESULT IF THE INSTRUCTIONS ARE NOT FOLLOWED PROPERLY
 <b>CAUTION</b>	THIS SIGNAL WORD IS USED WHERE MINOR INJURY COULD RESULT IF THE INSTRUCTIONS ARE NOT FOLLOWED PROPERLY
NOTICE	NOTICE INDICATES A PROPERTY DAMAGE MESSAGE

### GENERAL SAFETY PRECAUTIONS

#### WARNING! READ MANUAL PRIOR TO INSTALLATION



Improper installation, operation, or maintenance of this equipment could result in serious injury or death. Operation and maintenance personnel should read this manual, as well as all manuals related to this equipment and the Tractor thoroughly before beginning installation, operation, or maintenance. **FOLLOW ALL SAFETY INSTRUCTIONS IN THIS MANUAL AND THE TRACTOR'S MANUAL(S).**



#### **READ AND UNDERSTAND ALL SAFETY STATEMENTS**

Read all safety decals and safety statements in all manuals prior to operating or working on this equipment. Know and obey all OSHA regulations, local laws, and other professional guidelines for your operation. Know and follow good work practices when assembling, maintaining, repairing, removing, or operating this equipment.



#### **KNOW YOUR EQUIPMENT**

know your equipment's capabilities, dimensions and operations before operating.

Visually inspect your equipment before you start, and never operate equipment that is not in proper working order with safety devices intact. Check all hardware to ensure it is tight. Make certain that all locking pins, latches, and connection devices are properly installed and secured. Remove and replace any damaged, fatigued, or excessively worn parts. Make certain all safety decals are in place and are legible. Keep decals clean, and replace them if they become worn and hard to read

## GENERAL SAFETY PRECAUTIONS

### WARNING! PROTECT AGAINST FLYING DEBRIS



Always wear proper safety glasses, goggles or a face shield when driving pins in or out, or when any operation causes dust, flying debris, or any other hazardous material.

### WARNING! LOWER OR SUPPORT RAISED EQUIPMENT



Do not work under raised booms without supporting them. Do not use support material made of concrete blocks, logs, buckets, barrels or any other material that could suddenly collapse or shift positions. Make sure support material is solid, not decayed, warped, twisted, or tapered. Lower booms to ground level or onto blocks. Lower booms and attachments to the ground before leaving the cab or operator's station.

### WARNING! USE CARE WITH HYDRAULIC FLUID PRESSURE



Hydraulic fluid under pressure can penetrate the skin and cause serious injury or death. Hydraulic leaks under pressure may not be visible. Before connecting or disconnecting hydraulic hoses, read and Tractors operator's manual for detailed instruction on connecting and disconnecting hydraulic hoses or fittings

- Keep unprotected body parts, such as face, eyes, and arms as far away as possible from a suspected leak. Flesh injected with hydraulic fluid may develop gangrene or other permanent disabilities.
- If injured by injected fluid, see a doctor at once. If your doctor is not familiar with this type of injury, ask him to research immediately to determine proper treatment.
- Wear safety glasses, protective clothing, and use a sound piece of cardboard or wood when researching for hydraulic leaks. **DO NOT USE YOUR HANDS!** SEE ILLUSTRATION.

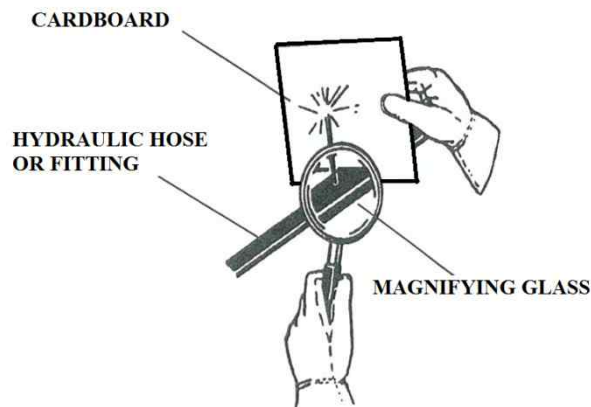

## GENERAL SAFETY PRECAUTIONS

### **WARNING! DO NOT MODIFY MACHINE OR ATTACHMENTS**



Modifications may weaken the integrity of the attachment and may impair the function, safety, life and performance of the attachment. When making repairs, use only manufacturer's genuine parts, following authorized instructions. Other parts may be substandard in fit and quality. Never modify any ROPS (Roll over Protection Structure) or FOPS (Falling object Protective Structure) equipment or device. Any modifications must be authorized in writing by the manufacturer.

### **WARNING! SAFELY MAINTAIN AND REPAIR EQUIPMENT**



Do not wear loose clothing, or any accessories that can catch in moving parts.

- If you have long hair, cover or secure it so that it does not become entangled in the equipment.
- Work on a level surface in a well-lit area.
- Use properly grounded electrical outlets and tools.
- Use the correct tool for the job at hand. Make sure they are in good condition for the task required.
- Wear the protective equipment specified by the tool manufacturer.

### **WARNING! SAFELY OPERATE EQUIPMENT**



Do not operate equipment until you are completely trained by a qualified operator in how to use the controls. Know its capabilities, dimensions, and all safety requirements.

See your machine's manual for these instructions.

- Keep all step plates, grab bars, pedals, and controls free of dirt, grease, debris, and oil.
- Never allow anyone to be around the equipment when it is operating.
- Do not allow riders on the attachment or the Tractor.
- Do not operate the equipment from anywhere other than the correct operators position.
- Never leave equipment unattended with the Engine running or with this attachment in a raised position.
- Do not alter or remove any safety feature from the Tractor or this attachment.
- Know your work site safety rules as well as traffic rules and the flow. When in doubt on any safety issue, contact your supervisor or safety coordinator for an explanation

## EQUIPMENT SAFETY PRECAUTIONS

### **WARNING! KNOW WHERE UTILITIES ARE**



Observe overhead electrical and other utility lines. Be sure equipment will clear them. When digging, call your local utilities for location of buried utility lines, gas, water, and sewer, as well as any other hazard you may encounter.

### **WARNING! EXPOSURE TO RESPIRABLE CRYSTALLINE SILICA DUST ALONG WITH OTHER HAZARDOUS DUSTS MAY CAUSE SERIOUS OR FATAL RESPIRATORY DISEASE.**



It is recommended to use dust suppression, dust collection and if necessary personal protective equipment during the operation of any attachment that may cause high levels of dust.

### **WARNING! REMOVE PAINT BEFORE WELDING OR HEATING**



Hazardous fumes/dust can be generated when painted heated by welding, soldering or using a torch. Do all work outside or in a well ventilated area and dispose of paint and solvent properly. Remove paint before welding or heating.

When sanding or grinding paint, avoid breathing the dust, Wear an approved respirator. If you use solvent or paint stripper, remove stripper with soap and water before welding. Remove solvent or paint stripper contains and other flammable material from area. Allow fumes to disperse at least 15 minutes before welding or heating.

### **WARNING! END OF LIFE DISPOSAL**



At the completion of the useful life of the unit, drain all fluids and dismantle by separating the different materials (rubber, steel, plastic, etc). Follow all federal, state and local regulations for recycling and disposal of the fluid and components

### **WARNING! OPERATING THE ATTACHMENT**



- Do not exceed the lifting capacity of your Tractor.
- Operate only from the operator's station.
- When operating on slopes, drive up and down, not across. Avoid steep hillside operation, which could cause the Tractor to overturn.
- Reduce speed when driving over rough terrain, on a slope, or turning, to avoid overturning the vehicle.
- An operator must not use drugs or alcohol, which can change his or her alertness or coordination. An operator taking prescription or over-the-counter drugs should seek medical advice on whether or not he or she can safely operate equipment.



## EQUIPMENT SAFETY PRECAUTIONS

### **WARNING! OPERATING THE ATTACHMENT**



- Never heap or load heavy material where the combined weight of the bucket and material could exceed the rated lifting capacity of the backhoe.
- Be sure the load does not stick out too far in front of the bucket. A light load sticking out too far can have the same tipping effect as a heavy load carried in close.
- If the load appears to be unstable, lower the load, and repositioning the load to attain stability.
- When using the Backhoe, lift the load slightly and make sure that the load is secure. If the load appears to be an unstable, lower the load, and reposition the load to attain full stability.
- Before Exiting the Tractor, lower the attachment to the ground, turn off the Tractor's Engine, remove the key and apply the brakes.

### **WARNING! TRANSPORTING THE ATTACHMENT**



- Travel only with the attachment in a safe transport position to prevent uncontrolled movement. Drive slowly over rough ground and on slopes.
- When transporting on a trailer: secure attachment at recommended tie down locations using tie down accessories that are capable of maintaining attachment stability.
- When driving on public roads use safety lights, reflectors, Slow moving vehicle signs etc., to prevent accidents. Check local government regulations that may affect you.
- Do not drive close to ditches, excavators, etc., cave in could result.
- Do not smoke when refueling the Tractor. Allow room in the fuel tank for expansion. Wipe up any spilled fuel. Secure cap tightly when done.

### **WARNING! MAINTAINING THE ATTACHMENT**



- Before performing maintenance, lower the attachment to the ground, apply the brakes, turn off the engine, and remove the key.
- Never perform any work on the attachment unless you authorized and qualified to do so. Always read the operator service manual's before any repair is made. After completing maintenance or repair, check for correct functioning of the attachment. If not functioning properly, always tag "DO NOT OPERATE" until all problems are corrected.
- Worn, damaged or illegible safety decals must be replaced. New safety decals can be ordered from Dealer or manufacturer.
- Never make hydraulic repairs while the system is under pressure. Serious personal injury or death could result.
- Never work under a raised attachment.

## DECALS

### DECAL REPLACEMENT

#### GENERAL INFORMATION

The following diagrams show the location of all the decals on your attachment.

The decals are identified by their parts numbers, with the reductions of the actual decals shown on the following pages. Use this information to order replacements for lost or damaged decals. Be sure you understand all decals before operating the attachment. They contain information you need to know for attachment safety. (See decal explanations.)

**IMPORTANT:** Keep all safety decals clean and legible. Replace all missing, or damaged safety decals. When replacing parts with safety decals attached, the safety decals must also be replaced.

**REPLACING SAFETY DECALS:** Clean the area of application with nonflammable solvent, then wash the same area with soap and water. Allow the surface to dry. Remove the backing from the safety decal, exposing the adhesive surface. Apply the safety decal to the position shown in the diagram, and smooth out any bubbles.



**BH75-902020**

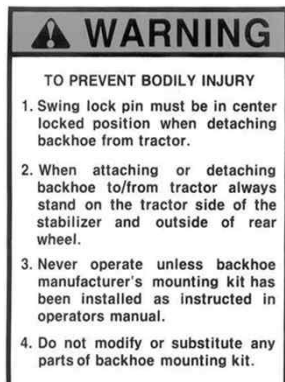

**BH75-902030**



**BH75-902040**



**BH75-902050**

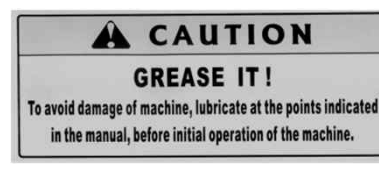

**BH75-902060**



**9031-504-008-0**

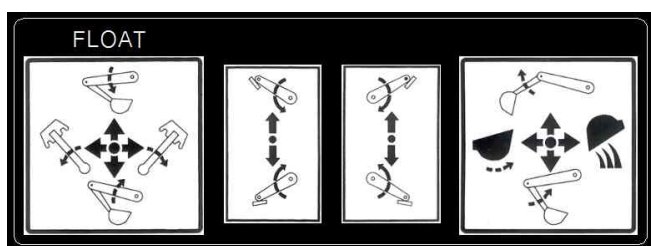

**Y100-901020**



**BH75-902070**



**8513-500-003-0**

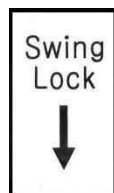

**BH75-902080**

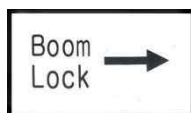

**BH75-902090**



**1144-910-003-0**



**9010-501-007-2**



# Backhoe Specifications

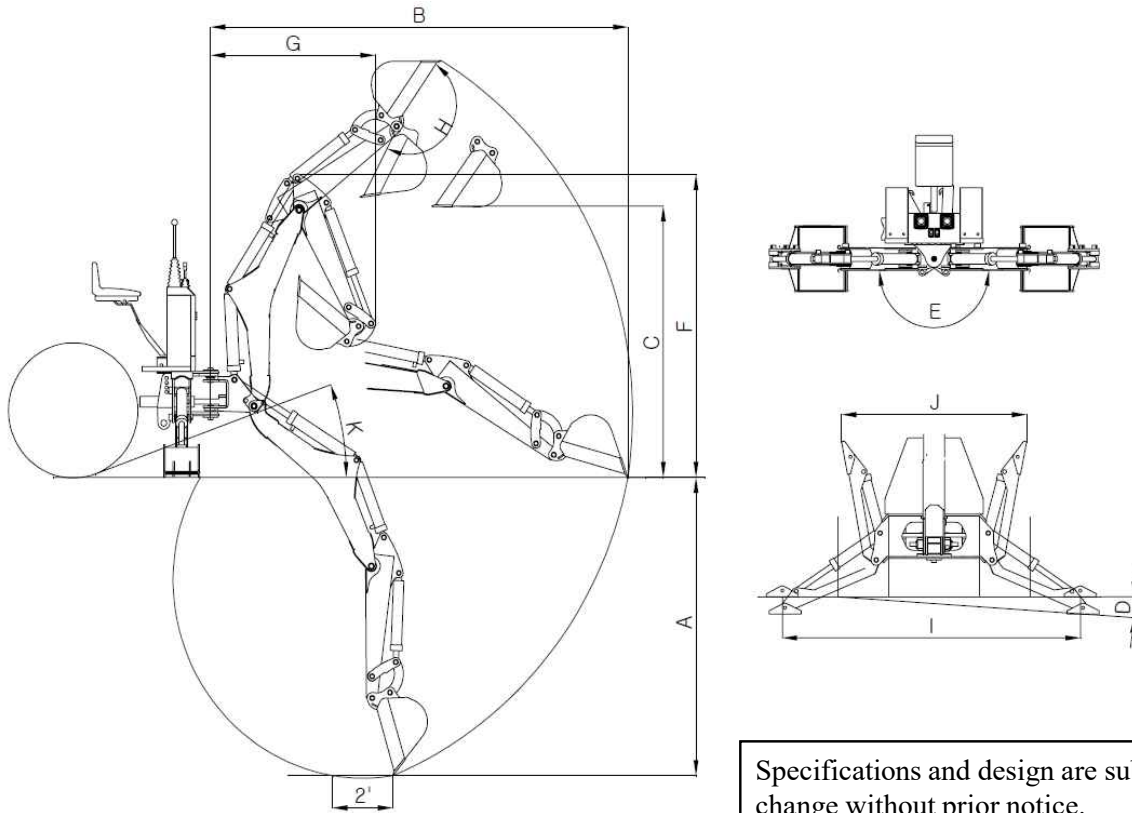

Specifications and design are subject to change without prior notice.

Backhoe Model : BH250  
 Applied Tractor Model : **TYM**

A	Digging Depth (two foot flat bottom)	2,620 mm ( 103.1" )	
B	Reach from center line of Swing Pivot	3,410 mm ( 134.3" )	
C	Loading Height(Bucket at 60°)	1,910mm ( 75.2" )	
D	Maximum Leveling Angle	13°	
E	Swing Angle	180°	
F	Transport height(Maximum)	2,040 mm ( 80.3" )	
G	Transport overhang	1,410 mm ( 55.5" )	
H	Bucket Rotation	161°	
I	Stabilizer Spread(Down Position)	2,544 mm ( 100.2" )	
J	Stabilizer Spread(Raise Position)	1,926mm (75.8" )	
K	Angle of Departure Shipping Weight (less bucket) Bucket Digging Force Dipper stick Digging Force Operation Pressure	21° 680Kg(1,500 lbs.) 2,012Kg(4,435 lbs.) 1,222Kg(2,694 lbs.) 165Kg/cm <sup>2</sup> (2,346psi)	

Specifications may vary depending on tractor model, tire size and bucket used.

## Cylinders

Cylinder	Bore Dia.		Retracted length		Stroke		Rod Dia.	
	mm	inch	mm	inch	mm	inch	mm	Inch
Boom	70	2.756	795	31.299	391	15.394	40	1.575
Bucket	60	2.362	770	30.315	300	11.811	35	1.378
Dipper stick	70	2.756	614	24.173	388	15.276	40	1.575
Swing	60	2.362	385	15.157	220	8.661	25	0.984
Stabilizer	60	2.362	670	26.378	305	12.008	35	1.378

## Bucket

Part No.	Bucket	Teeth Q'ty	Struck Capacity	Heaped Capacity	Shipping weight
BY400-610002GB	9" bucket	3	0.73 cu.ft	0.87cu.ft	46 lbs.
BY400-620002GB	12" bucket	3	1.04 cu.ft	1.24cu.ft	56 lbs.
BH250-600001GB	16" bucket	4	1.38 cu.ft	1.76cu.ft	64 lbs.
BY400-630003GB	18" bucket	4	1.56 cu.ft	2.02cu.ft	70 lbs.
BY400-640001GB	24" bucket	No Teeth	2.11cu.ft	2.82cu.ft	94lbs.
BY400-650001GB	36" bucket	No Teeth	2.78cu.ft	4.0cu.ft	114 lbs.

## Introduction.

The purpose of this manual is to assist you in maintaining and operating your backhoe. Read it carefully, it furnishes information and instructions that will help you achieve years of dependable performance. Some information may be general in nature due to unknown and varying conditions. However, through experience and these instructions, you should be able to develop operating procedures suitable to your particular situation.

"Right" and "Left" as used throughout this manual are determined by facing the direction the machine will travel when in use.

The photos, illustrations and data used in this manual are current at the time of printing, but due to possible in-line production changes, your machine may vary slightly in detail. The manufacturer reserves the right to redesign the machine as may be necessary without notification.

## Backhoe Components.

Terms for backhoe components have some variations throughout the industry.

## Important:

Illustrations used in this manual may not show all safety equipment that is recommended to ensure safe operation of tractor and backhoe. Refer to the Safety Precautions section of this manual for information concerning safety. consult your dealer for further information.

## Warranty Registration

The Delivery and Warranty Registration forms must be filled out and signed to validate your warranty protection. The items on the form under "I hereby Acknowledge" should be read and understood. The terms and conditions of the warranty on this machine are specified in the front of this manual.

## Serial Number and Location

The serial number is important information about the machine and it may be necessary to know it before obtaining the correct replacement part. The serial number is located on the front of valve cover. The serial number should be recorded on the Delivery and Registration form and also below for your reference.

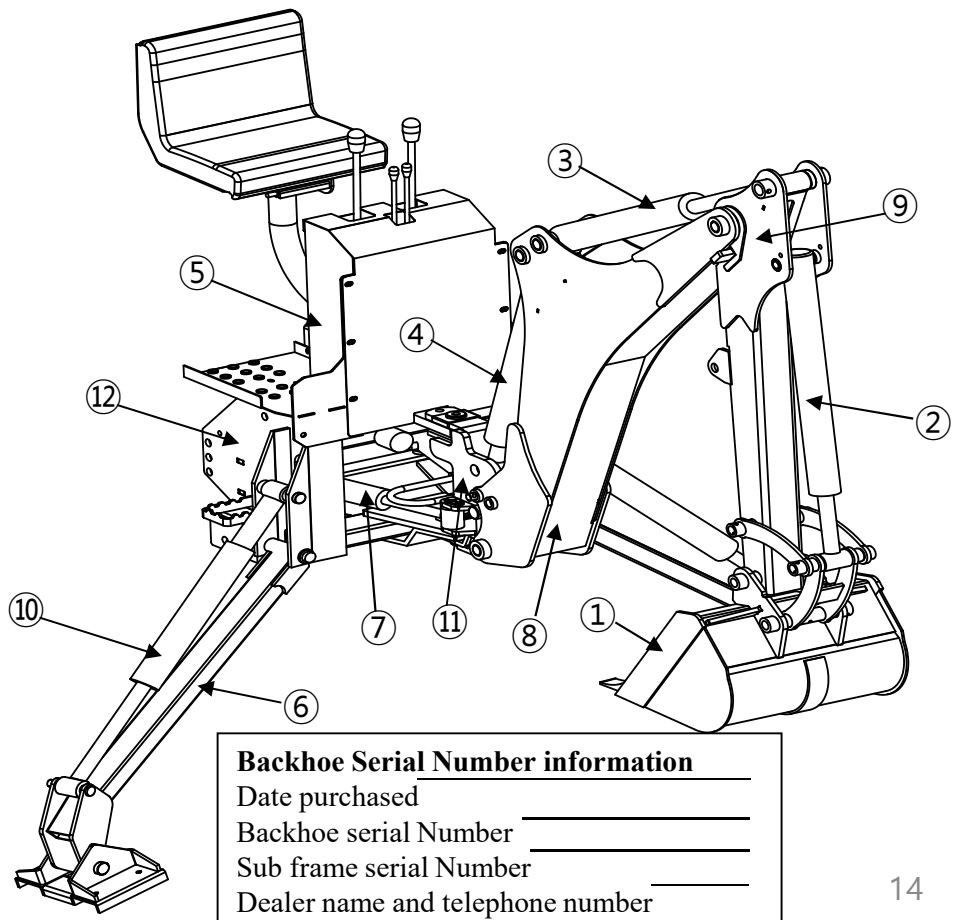

## TRACTOR PREPARATION



### CAUTION

Do not exceed the manufacturer's rating for maximum gross vehicle weight. Refer to Operator's Manual or ROPS serial plate provided with tractor.



### CAUTION

Certain specific conditions may not permit safe use of backhoe at backhoe rating or may require more careful restricted operation at the rated load.

### ROPS System

The tractor must be equipped with an approved ROPS System to ensure adequate operator's protection.



### CAUTION

The tractor/backhoe must only be operated with all safety equipment properly installed.

### Tire Inflation

Front tires must be maintained at the maximum recommended inflation to maintain normal tire profile with the added weight of backhoe/material.

Rear tires must be maintained at equal pressure within the recommended tire inflation range. Unequal rear tire inflation can prevent backhoe attachment from contacting the ground across its full width.

### Tractor Hydraulic System

Tractor operation in a backhoe application significantly increase demands on the tractor Hydraulic System. Check the tractor Hydraulic system fluid level daily. Refer to your tractor Operator's Manual maintenance section for instructions regarding tractor hydraulic system maintenance.

Adhere to recommendation in your Tractor Operator's Manual concerning hydraulic fluid and filter specifications, and change intervals.

### Wheel Tread Settings

Tractor front wheel tread setting must be restricted to wheel tread spacing recommended in the tractor Operator's Manual.

## BACKHOE OPERATION



### CAUTION

The tractor/backhoe should only be operated with all safety equipment properly installed. Keep assistants or bystanders a safe distance from the equipment operating area.

#### Precautionary Notes

- Check below items before operating for your safety.
- Read and understand this manual to avoid accidents.
- Check the hydraulic fitting lines to be correct and set tightly.
- Maintain and repair (if it is needed) the parts or assemblies, check bolts and pins to be sure they are positioned tightly.
- Check tractor with the tractor operator's manual that it can prepared for operating.
- Warm up and operate the tractor and backhoe carefully. Purge any air in the hydraulic lines and cylinders by fully cycling all cylinders several times.
- Check hydraulic level in the tank. It should be full (Refer to the Tractor Operator's Manual).
- Do not operate the hydraulics when not seated in the backhoe operator's seat.
- Keep all assistants out of area of operation.
- Do not operate rapidly.
- Do not allow riders other than the operator to be on the tractor while operating.

#### Important:

Use tractor engine speed that your experience permits. At first set PTO RPM of the tractor to slow. Do not use the boom, dipper stick, swing and stabilizers to lift, push or pull objects. Use only to maneuver and operate the bucket.

#### Important:

Practice quickly turning off the engine or stopping the backhoe immediately in case of an emergency situation.

#### Important:

Do not operate while the rear tractor wheels are off the ground by stabilizer. It is dangerous to operate the backhoe while rear wheels are off the ground.

Position vehicle so that the backhoe is as near to the pile as possible and in such a direction as to minimize the amount of tractor turning required to dump.

Keep the unit clean and perform regular service. Observe safety messages whenever cleaning, servicing, or lubricating.

We urge you to follow this advice:

1. Read and understand this manual as well as the Tractor Operator's Manual.
2. Remember and observe the Safety. Precautions brought to your attention in this manual, the tractor manual and on the machinery itself.
3. Use good common sense in the everyday operation of this unit. Safety recommendations can never be all inclusive and you are responsible for watching out for and avoiding unsafe conditions.
4. Never exceed the limits of a piece of machinery. If its ability to do a job or to do so safely is in question, don't try it.
5. Don't hurry the learning process or take the unit for granted. Ease into it and become familiar with your new backhoe and tractor.



**CAUTION:** When lowering a heavy load, ease it downward slowly. Never drop a loaded attachment and "catch it hydraulically". Stopping a load after it has gained downward momentum places undue strain on the unit and may cause unnecessary damage to the backhoe or tractor or even worse, personal injury.



**CAUTION:** Before disconnecting hydraulic lines, relieve all hydraulic pressure. Escaping hydraulic oil under pressure can have sufficient force to penetrate the skin causing serious personal injury. If injured by escaping hydraulic oil seek medical attention immediately.



**CAUTION:** Do not operate the backhoe if the fittings are leaking or if the hoses are damaged. A sudden line burst would cause the mainframe to drop suddenly, causing damage to the tractor or backhoe or injury to personnel.



### Initial Backhoe Operation

Before operating the backhoe, fully raise and lower the boom, arm, swing and stabilizers two or three times. Then raise the bucket above the ground and cycle the bucket cylinders three times. Lower the bucket to the ground. Check the tractor hydraulic oil and the correct oil level.



#### CAUTION:

Before leaving the machine, stop the engine, remove the key, place all controls in neutral, and either set the parking brake or place tractor in park as equipped.



CAUTION : Operate controls only when seated in the operator's seat.

Always keep cylinders in a retracted position when the backhoe is not in use to guard against rust and contamination which may cause damage to the cylinder rods or hydraulic system.

Also, lock the swing and boom while tractor is moving and storing for an extended period of time.

### Cold Weather Operation

For smooth operation in cold weather, let the tractor warm up. Slowly cycle all of the cylinders several times to warm the oil in the hydraulic system. The backhoe may operate erratically until the hydraulic oil has warmed to operating temperatures.

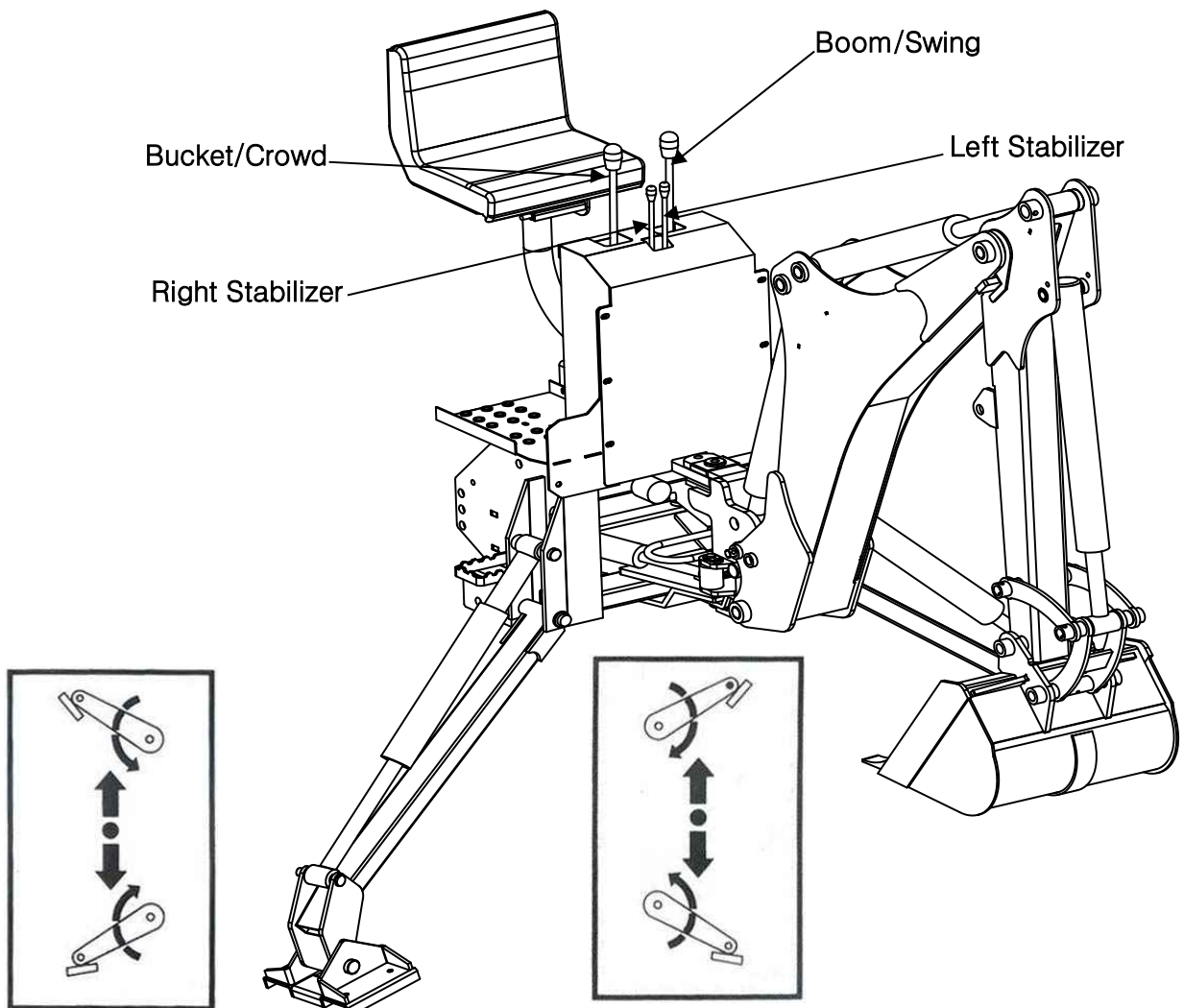

Left hand Stabilizer Decal

Right hand Stabilizer Decal

Push the right hand inner control lever, right stabilizer lowers. And pull up the lever, right stabilizer raises.

Do not dig near the stabilizers to avoid possible accident.

Do not lift the tractor rear wheels by stabilizers. Also, be sure the stabilizers are seated on hard ground to support. The backhoe/tractor.

### Boom and swing controls

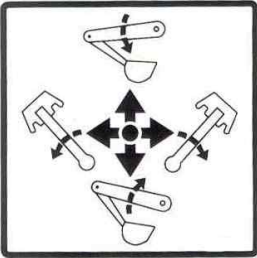

Push the left hand outer control lever, boom moves down, and pull back the lever, boom moves up. Also, pushing the lever fully forward into the detent position, allows the boom to float. In the float position, the boom can drift up or down without pressure.

Move the left hand outer control lever to the left, boom swings to the left. Move lever right, backhoe boom swing moves to the right.

### Bucket and crowd controls

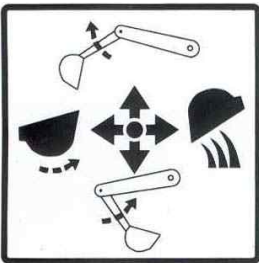

Push the right hand outer control lever, arm(dipper stick) moves away from operator, and pull back the lever, arm(dipper stick) moves toward the operator.

Move the right hand outer control lever to the left, bucket curls in. Move lever right, bucket extends out from operator.

These two levers ( Boom and swing control lever, Bucket and crowd control lever ) provide four simultaneous operations. Both experience and practice are needed to eliminate excess motion and increase operating efficiency.

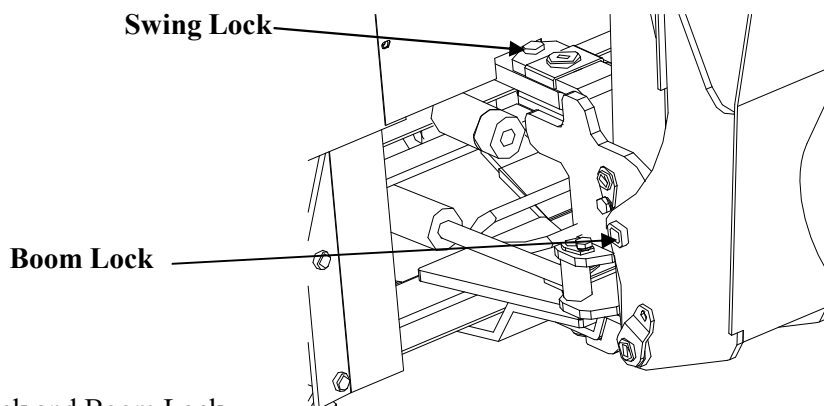

### Swing Lock and Boom Lock

When transporting or dismounting backhoe, you must lock the backhoe's swing and boom.

Position boom straight back and drop pin through holes in swing frame and boom. When not in use, store pin in hole provided on swing frame and boom.

Observe the following safety warnings when working with your new backhoe/tractor.



**CAUTION:**

When using a backhoe, be aware of bucket and boom location at all times.

When raising A arm(dipper stick) with bucket rolled forward, material can spill onto non target area causing injury to assistant or damage other objects.



**CAUTION:**

Do not dig near stabilizers. Ground under stabilizers could collapse. Make all movements slow and gradual when practicing operation.



**CAUTION:**

Operate from backhoe operators seat only. Pay attention, be ready to stop, immediately in case of an emergency.



**CAUTION:**

To help prevent roll-over, adjust the rear wheels to their widest setting to maximize stability. Refer to your Tractor Operator's Manual for recommendations.

## **BACKHOE REMOVAL**



**CAUTION:**

Move the backhoe to flat, firm and wide place to remove the equipment.



**CAUTION:**

Do not allow to be removed without bucket and stabilizers. Also, Dump the remaining material from the bucket to empty.



**WARNING:**

Use other lifting equipment to remove when the backhoe has damage.

### **STEP 1.**

Move the tractor to backhoe storage place.

### **STEP 2.**

Use the inner two levers to lower the stabilizers until they contact to the ground. Use the boom and dipperstick control lever to raise the boom & dipper stick completely.

### **STEP 3.**

Center the boom and then lock the swing with lock pin.

**STEP 4.**

Using the control levers, position the dipperstick vertically, curl the bucket until its bottom is level with the ground, and lower the boom until bottom of the bucket rests on the ground.

**STEP 5.**

Remove pins that secure the backhoe. Sub-frame in the mounting brackets on the tractor.

**STEP 6.**

Using both the stabilizer and boom controls, set the backhoe sub-frame horizontally to relieve the weight of the backhoe from the mounting brackets of the tractor.

**STEP 7.**

Move the tractor forward slowly until the backhoe sub-frame disengages of the mounting brackets.

**STEP 8.**

Lower the backhoe mainframe to the ground by raising stabilizers and boom. Use the wood plate or block if necessary.

**STEP 9.**

Turn off the tractor engine. Relieve hydraulic pressure by actuating all the control levers in each direction, then disconnect the backhoe hose couplers from the tractor hydraulic couplers.



**CAUTION:**

Remove the backhoe on firm level ground. Also, Do not allow the other person in the area.



**CAUTION:**

Be careful to avoid injury during removal of the backhoe.



**CAUTION:**

The hydraulic oil is dangerous for skin or eyes. Wash the skin and seek medical service if it is necessary.

## **BACKHOE MOUNTING**



**CAUTION:**

Backhoe should be mounted on the proper sub-frame assembly.



**CAUTION:**

Never store backhoe without bucket attached to the backhoe.

**STEP 1.**

Attach the loader mid-mount and mounting-kit to the tractor by fit the bolts and nuts.

**STEP 2.**

Back tractor slowly toward the backhoe parallel to mounting-kit assembly, until the couplers on the backhoe hoses are able to connect with the hose kit hydraulic couplers or tractor auxiliary couplers located rear of the tractor. Then, put the couplers to connected.

**STEP 3.**

Store the mounting-kit and mounting bracket horizontally with the loader mid-mount and mounting bracket by the backhoe control lever. Also, matching these on same level

**STEP 4.**

Set the parking brake of the tractor, Make sure the PTO switch is in the off position

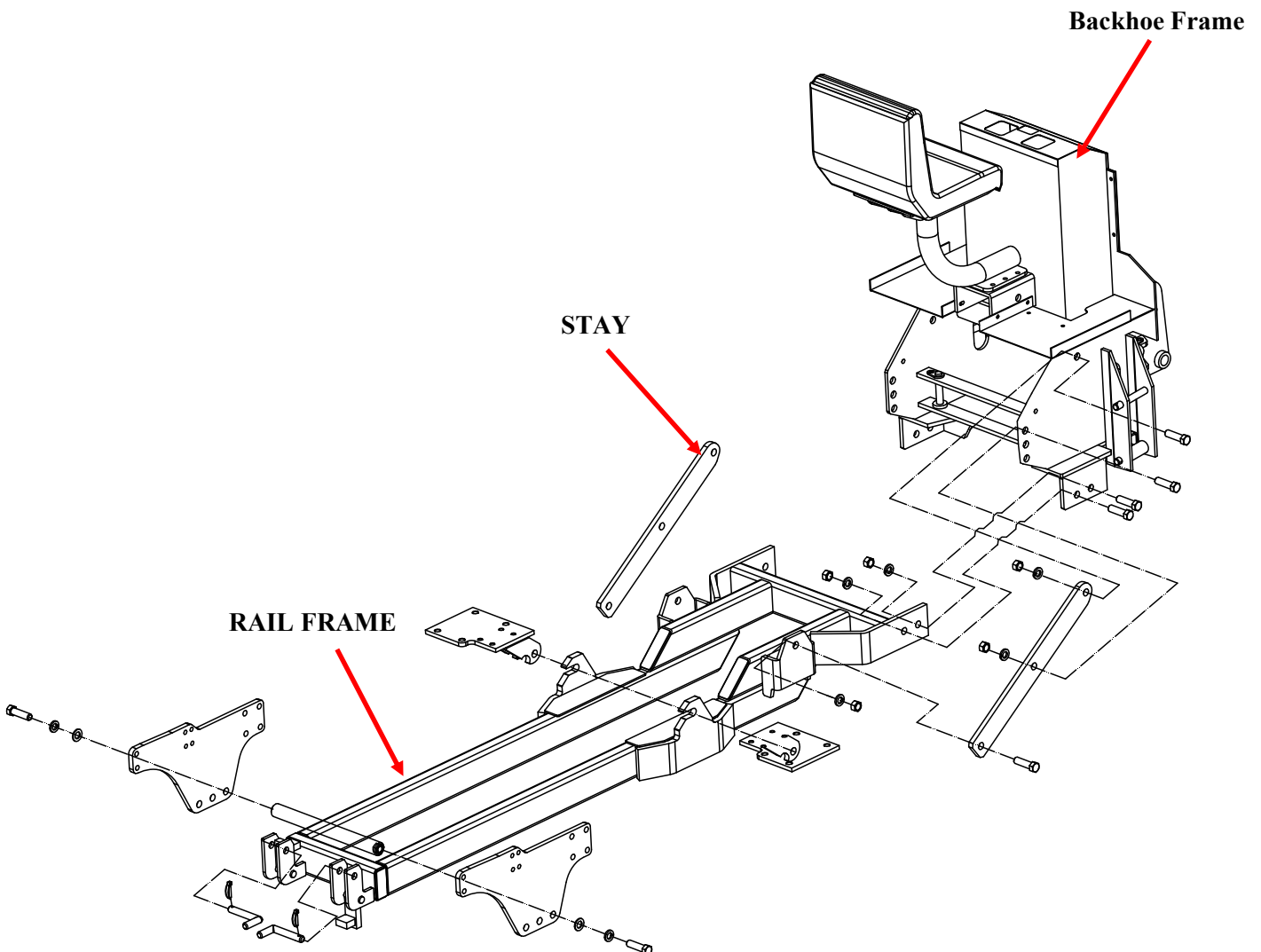



**CAUTION:**

This is the Backhoe's Operator's manual for Safety Precautions and Tractor Preparations.

**STEP 5.**

Move the tractor to put the mounting-kit front side into the mounting bracket slowly.

**STEP 6.**

Release the parking brake of tractor, move the tractor rearward very carefully until the mounting-kit is fully engaged in both mounting devices on the tractor.

**STEP 7.**

Install the Mounting Bracket Pins into the holes. Raise the boom and stabilizers from the ground.

## LUBRICATION AND MAINTENANCE

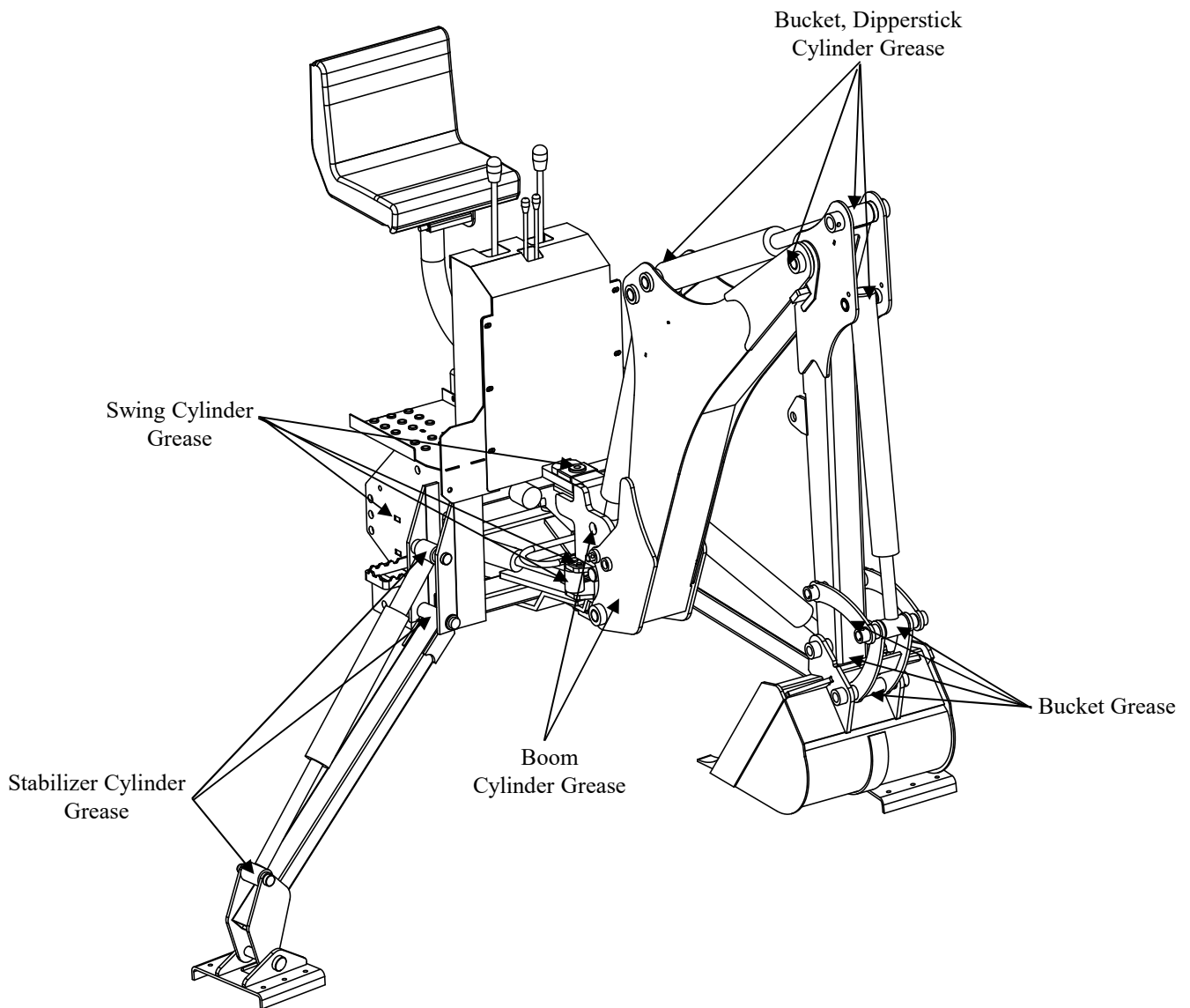

ITEM	SERVICE	SERVICE INTERVAL
Hydraulic System Oil Level	Replace	As specified in Tractor Operator's Manual
Hydraulic System Oil Level	Check	Daily/10 hours
Hydraulic System Oil/Filter	Replace	As specified in Tractor Operator's Manual
Tire Inflation	Check	Weekly/50 hours
Backhoe Pivot Points	Lubricate	Daily/10 hours
Backhoe Hydraulic Lines, Hoses, Connections	Check for leaks, wear	Daily/10 hours
Boom, Dipperstick, Swing and Bucket cylinder rod packing	Check for seepage, service as needed	Daily/10 hours
Pivot pin bolts and dust covers	Check, replace if missing	Daily/10 hours
Friction of All pins	Check, replace if necessary	Daily/10 hours
Backhoe mount hardware	Check visually	Daily/10 hours
Bolts and Nut release	Re-torque	Every 25 hours

## LUBRICATION AND MAINTENANCE



### CAUTION:

Do not perform service or maintenance Operations with backhoe raised off the ground. For additional access to tractor components remove backhoe.

### Important:

Lower the backhoe to the ground and relieve pressure in backhoe hydraulic lines prior to performing any service or maintenance operations on the tractor or backhoe.



### CAUTION:

Escaping fluid under pressure can have sufficient force to penetrate the skin, causing serious injury. Before disconnecting lines, be sure to relieve all pressure. Before applying pressure to the system, be sure all connections are tight and that lines, pipes and hoses are not damaged. Fluid escaping from a very small hole can be almost invisible. Use a piece of cardboard or wood rather than your hands to search for suspected leaks. If injured by escaping fluid, seek medical attention immediately. Serious infection or reaction can develop if correct medical treatment is not administered immediately.

Refer to "Lubrication and Maintenance Chart" for quick reference to Maintenance Operations.



### CAUTION:

Do not operate the backhoe if the fittings are leaking or if the hoses are damaged. A sudden line burst could cause the boom, dipperstick or bucket to drop suddenly, causing damage to the tractor or backhoe or injury to personnel..



### CAUTION:

Operate the backhoe from the operator seat only.



### CAUTION:

Do not stand or walk under a raised backhoe. Accidental movement of control lever or leak in hydraulic system could cause boom or dipper stick to drop, causing severe injury.

Check the tractor hydraulic system as outlined in the Tractor Operator's Manual.

### NOTE:

When checking hydraulic system oil level, the backhoe should be on the ground and bucket fully retracted(all cylinders in retracted position).

Grease all backhoe pivot points daily(10 hours). Refer to Tractor Operator's Manual for lubricant recommendations.

Inspect hydraulic hoses, connections, control valve and cylinders for evidence of leakage.

Tractor tires should be maintained at maximum recommended inflation to maintain normal tire profile with added weight of backhoe/material. Unequal rear tire inflation can result in bucket not being level to the ground.



## TROUBLE SHOOTING

This Trouble Shooting Chart is provided for reference to possible backhoe operational problems. Determine the problem that best describes the operational problem being experienced and eliminate the possible causes as listed by following the correction procedures.

PROBLEM	POSSIBLE CAUSE	CORRECTION
Swing, Boom, Dipper stick and Bucket Cylinders	Low hydraulic fluid level.	Check and replenish hydraulic fluid.
	Hydraulic hoses connected improperly.	Check and correct hydraulic hose connections.
	Hydraulic hoses to/from control valve Blocked	Check for damage(kinked) hoses, etc.
	Backhoe control valve or tractor main relief valve stuck open.	Check system pressure. Repair or replace relief valve. Refer to the Tractor Operator's Manual
	Low system pressure supplied from hydraulic pump.	Check system pressure. Repair or replace pump.
	Control valve linkage broken.	Inspect. Repair as required.
	Quick disconnect coupler(s) are not fully connected or "Flow Check"	Check coupler connections. Replace coupler(s) if necessary.
	Hydraulic hose or tube line blockage.	Check for evidence of damage to hoses or tube lines that would block flow of oil between cylinders and control valve.
	Cylinder piston assembly defective (not sealing)	Check cylinders for internal leakage as described in service section under cylinder leakage tests.
	control valve blockage.	Inspect for blockage. Disassemble valve if necessary.
Cylinders operate in wrong direction relative to control valve lever position.	Hydraulic hoses connected incorrectly.	Correct hydraulic hose connections.
Aeration of Hydraulic Fluid(Generally indicated by foamy appearance of fluid).	Low hydraulic fluid level.	Check and refill hydraulic system to proper level.
	Air leaking into suction side of hydraulic pump.	Check for loose or defective connections between reservoir and hydraulic pump.
	Hydraulic fluid foaming due to improper hydraulic oil usage.	Refer to Tractor Operator's Manual and replace hydraulic oil using recommended hydraulic oil.

PROBLEM	POSSIBLE CAUSE	CORRECTION
Slow or erratic move of Cylinders (Noisy operation of cylinders)	Low hydraulic fluid level.	Check and replenish hydraulic fluid.
	Cold hydraulic fluid.	Allow hydraulic system to warm up to operating temperature.
	Engine R.P.M. too slow (hydraulic pump R.P.M. too slow).	Increase engine speed to obtain satisfactory backhoe operation.
	Excessive weight in bucket. Material weight exceeds maximum specified backhoe capacity.	Reduce material load. (Digging load)
	Control valve linkage binding/defective.	Check control valve linkage and repair if worn/defective.
	Aeration of hydraulic fluid	Refer to "Aeration of Hydraulic Fluid".
	Quick disconnect coupler restriction or coupler "Flow checks"	Check coupler connections. Repair or replace.
	Hydraulic hose or tube line restriction (hoses/tube line) kinked or pinched.	Check hoses and tube lines for evidence of restriction.
	Boom, Dipper stick or Bucket cylinder piston assembly leakage.	Check cylinders for leakage. Repair as needed.
	Relief valve erratic or set below specifications.	Check and reset relief valve. Setting as needed.
Inadequate lifting capacity	Control valve leaking internally. (hy-passing fluid within valve).	Replace control valve and recheck operation.
	Hydraulic Oil viscosity too heavy or Incorrect oil	Check oil number and viscosity, Refill correct hydraulic oil.
	Engine R.P.M. too slow.	Increase engine R.P.M.
	Excessive load - material weight exceeds specified loader capacity.	Reduce Load.
	Relief valve setting below specifications.	Check and reset relief valve setting as needed.
	Bucket, Boom and Dipper stick cylinder piston assembly leakage.	Check cylinders for leakage. Repair as needed.
Control valve leaking internally	Replace control valve and recheck operation.	
Hydraulic pump defective.	Refer to "Hydraulic Pump Capacity Inadequate".	

PROBLEM	POSSIBLE CAUSE	CORRECTION
System relief valve squeals.	Hydraulic Oil viscosity too heavy or Incorrect oil	Check oil number and viscosity, Refill correct hydraulic oil.
	Excessive load in bucket. Weight exceeds specified backhoe capacity.	Reduce load.
	Relief valve setting below specifications	Check and reset valve setting as needed.
	Hydraulic hose, tube line or quick disconnect coupler restriction.	Check for evidence of restriction in hydraulic oil flow. Repair or replace defective components.
Backhoe drops with control valve spool in "centered" position (no external oil leakage evident.) Note: A gradual drop over an extended period of time is a normal condition.	Cylinder piston assembly leakage.	Check cylinders for leakage.
Control valve spool(s) will not return to centered position.	Control valve internal leakage.	Replace control valve and recheck.
	Control lever linkage binding.	Determine origin of binding and repair.
	Control valve spool centering is broken.	Replace centering spring.
External hydraulic fluid leakage.	Control valve spool binding in valve body spool bore.	Disassemble valve for inspection and repair.
	Loose hydraulic connection.	Tighten loose connections.
	Defective hydraulic hose, tube line, adapter fitting or adapter fitting o-ring.	Check for origin of oil leak and replace defective part.
	Control valve O-rings defective.	Replace defective O-rings.
	Control valve spool or body damaged or worn.	Replace control valve.
Hydraulic pump capacity inadequate.	Cylinder rod packing set leakage.	Check cylinders for leakage. Repair as needed.
	Cold hydraulic fluid.	Allow hydraulic fluid to warm up to operating temperature.
	Engine R.P.M. too slow.	Increase engine R.P.M.
	Low hydraulic fluid supply.	Refer to Tractor Operator's Manual for service recommendations.
	Hydraulic hose restriction.	Check for evidence of restriction in hydraulic hoses.
cylinder rod bend when lift cylinders extended.	Hydraulic pump defective.	Refer to Tractor Operator's Manual for recommended service procedures. Replace hydraulic pump if determined to be defective.
	Excessive shock load on lift cylinders during transport.	Replace defective parts. Review and observe proper and safe operational practices.

## Hydraulic system schematic

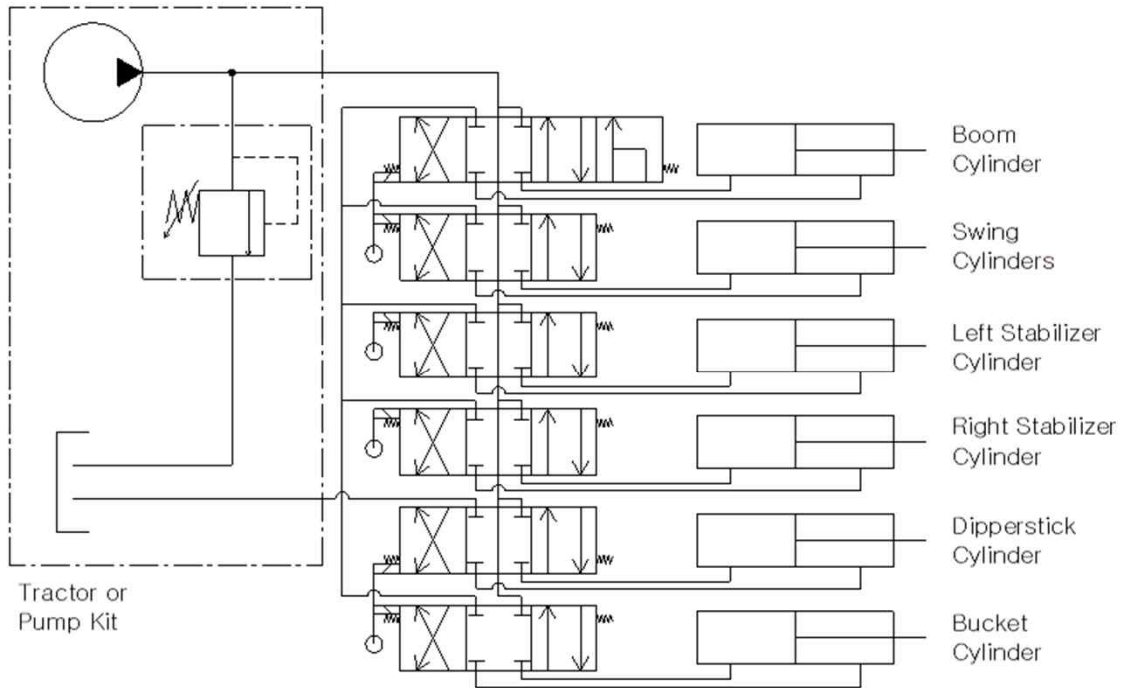



## BOLT TORQUE BOLT TORQUE SPECIFICATIONS

### GENERAL TORQUE SPECIFICATION TABLES

Use the following charts when determining bolt torque specifications when special torques are given. Always use grade 5 or better when replacing bolts.

### SAE BOLT TORQUE SPECIFICATIONS.

Note : The following torque values are for use with extreme pressure lubricants, plating or hard washer applications increase torque 15% when using hardware that is unplated and either dry or lubricated with engine oil.

Bolt Size		SAE GRADE 5 TORQUE				SAE GRADE 8 TORQUE				Bolt head identification marks as per grade. NOTE: Manufacturing Marks Will Vary
		Pounds Feet		Newton-Meters		Pounds Feet		Newton-Meters		
Inches	Millimeters	UNC	UNF	UNC	UNF	UNC	UNF	UNC	UNF	
1/4	6.35	8	9	11	12	10	13	14	18	<div style="text-align: center;"> <p>GRADE 2</p>  <p>GRADE 5</p>  <p>GRADE 8</p>  </div>
5/16	7.94	14	19	19	23	20	25	27	34	
3/8	9.53	30	36	41	49	38	46	52	62	
7/16	11.11	46	54	62	73	60	71	81	96	
1/2	12.70	68	82	92	111	94	112	127	152	
9/16	14.29	94	112	127	152	136	163	184	221	
5/8	15.88	128	153	174	207	187	224	254	304	
3/4	19.05	230	275	312	373	323	395	438	536	
7/8	22.23	340	408	461	553	510	612	691	830	
1	25.40	493	592	668	803	765	918	1037	1245	
1-1/8	25.58	680	748	922	1014	1088	1224	1475	1660	
1-1/4	31.75	952	1054	1291	1429	1547	1700	2097	2305	
1-3/8	34.93	1241	1428	1683	1936	2023	2312	2743	3135	
1-1/2	38.10	1649	1870	2236	2535	2686	3026	3642	4103	

### METRIC BOLT TORQUE SPECIFICATIONS.

Note : The following torque values are for use with metric hardware that is unplated and either dry or lubricated with engine oil. Reduce torque 15%, when using hardware that has extreme pressure lubricants, plating or hard washer applications.

Bolt head identification marks as per grade.		
		

Size of Bolt	Grade No.	Pitch (mm)	Pounds Feet	Newton-Meters	Pitch (mm)	Pounds Feet	Newton-Meters
M6	5.6	1.0	3.6-5.8	4.9-7.9	-	-	-
	8.8		5.8-4	7.9-12.7		-	-
	10.9		7.2-10	9.8-13.6		-	-
M8	5.6	1.25	7.2-14	9.8-19	1.0	12-17	16.3-23
	8.8		17-22	23-29.8		19-27	25.7-36.6
	10.9		20-26	27.1-35.2		22-31	29.8-42
M10	5.6	1.5	20-25	27.1-33.9	1.25	20-29	27.1-39.3
	8.8		34-40	46.1-54.2		35-47	47.4-63.7
	10.9		38-46	51.5-62.3		40-52	54.2-70.5
M12	5.6	1.75	28-34	37.9-46.1	1.25	31-41	42-55.6
	8.8		51-59	69.1-79.9		56-68	75.9-92.1
	10.9		57-66	77.2-89.4		62-75	84-101.6
M14	5.6	2.0	49-56	66.4-75.9	1.5	52-64	70.5-86.7
	8.8		81-93	109.8-126		90-106	122-143.6
	10.9		96-109	130.1-147.7		107-124	145-168
M16	5.6	2.0	67-77	90.8-104.3	1.5	69-83	93.5-112.5
	8.8		116-130	157.2-176.2		120-138	162.6-187
	10.9		129-145	174.8-196.5		140-158	189.7-214.1
M18	5.6	2.0	88-100	119.2-136	1.5	100-117	136-158.5
	8.8		150-168	203.3-227.6		177-199	239.8-269.6
	10.9		175-194	237.1-262.9		202-231	273.7-313
M20	5.6	2.5	108-130	146.3-176.2	1.5	132-150	178.9-203.3
	8.8		186-205	252-277.8		206-242	279.1-327.9
	10.9		213-249	288.6-337.4		246-289	333.3-391.6

## Warranty Registration Form & Delivery Inspection Report

**IMPORTANT!** Warranty Void if card is not returned within 10 days.

All Applicable sections **must** be filled in.

*This section to be filled out and signed by Dealer at time of delivery.*

Customer's Name _____	Dealer's Name _____
Address _____	Address _____
City _____ State _____ Zip _____	City _____ State _____ Zip _____
Phone _____	

**CHECK ONE:**

Loader / Tractor Model _____	<input type="checkbox"/> Agricultural Use	<input type="checkbox"/> Construction Use
Delivery Date _____	<input type="checkbox"/> Landscape Use	<input type="checkbox"/> Other _____
Brand & Model # _____		
Serial # _____		

**Dealer Inspection** *(check items applicable)*

- |   |   |
|---|---|
| <input type="checkbox"/> All Decals Installed (see operator's manual) | <input type="checkbox"/> Review Operating & Safety Instructions |
| <input type="checkbox"/> Hydraulic Fittings Tight & Free of Leaks     | <input type="checkbox"/> Guards & Covers in Place & Secure      |
| <input type="checkbox"/> Fasteners Tight                              | <input type="checkbox"/> Does Product Function Properly         |

I have thoroughly instructed the buyer on the above described equipment. This review included: The Operator's Manual content, equipment care, adjustments, safe operation and applicable warranty policy.

Dealer Rep. Signature: \_\_\_\_\_ Date: \_\_\_\_\_

*This section to be completed and signed by the Owner*

QUALITY ASSURANCE RATING	1=Excellent	2=Good	3=Average	4=unsatisfactory	5=poor
Question	Paladin Light Construction		Local Dealer		
Quality of Product: Appearance	_____				
Construction	_____				
Quality of Service	_____			_____	
Value (Priced Fairly)	_____			_____	
Does it perform as claimed	_____				

The above described equipment and Operator's Manual have been received by me and I have been thoroughly instructed as to care, adjustments, safe operation and applicable warranty policy.

Owner's Signature: \_\_\_\_\_ Date: \_\_\_\_\_

**NOTE!** Make one copy each for the dealer's and owner's records. Fax or mail to:

## **PART ILLUSTRATIONS**

### **GENERAL INFORMATION**

#### **Illustrations**

The individual parts in their normal relationship to each other. Reference numbers are used in the illustrations. These numbers correspond to those in the "Number" column and are followed by the quantity required and description.

#### **Directional Reference**

"Right hand" and "left hand" sides are determined by standing at the rear of the unit and facing in the direction of forward travel.

#### **Part Order**

Orders must give the complete description, correct part number, the total amount required, the product model, all the necessary serial numbers, the method of shipment and the shipping address.

FIG.101

SUB FRAME

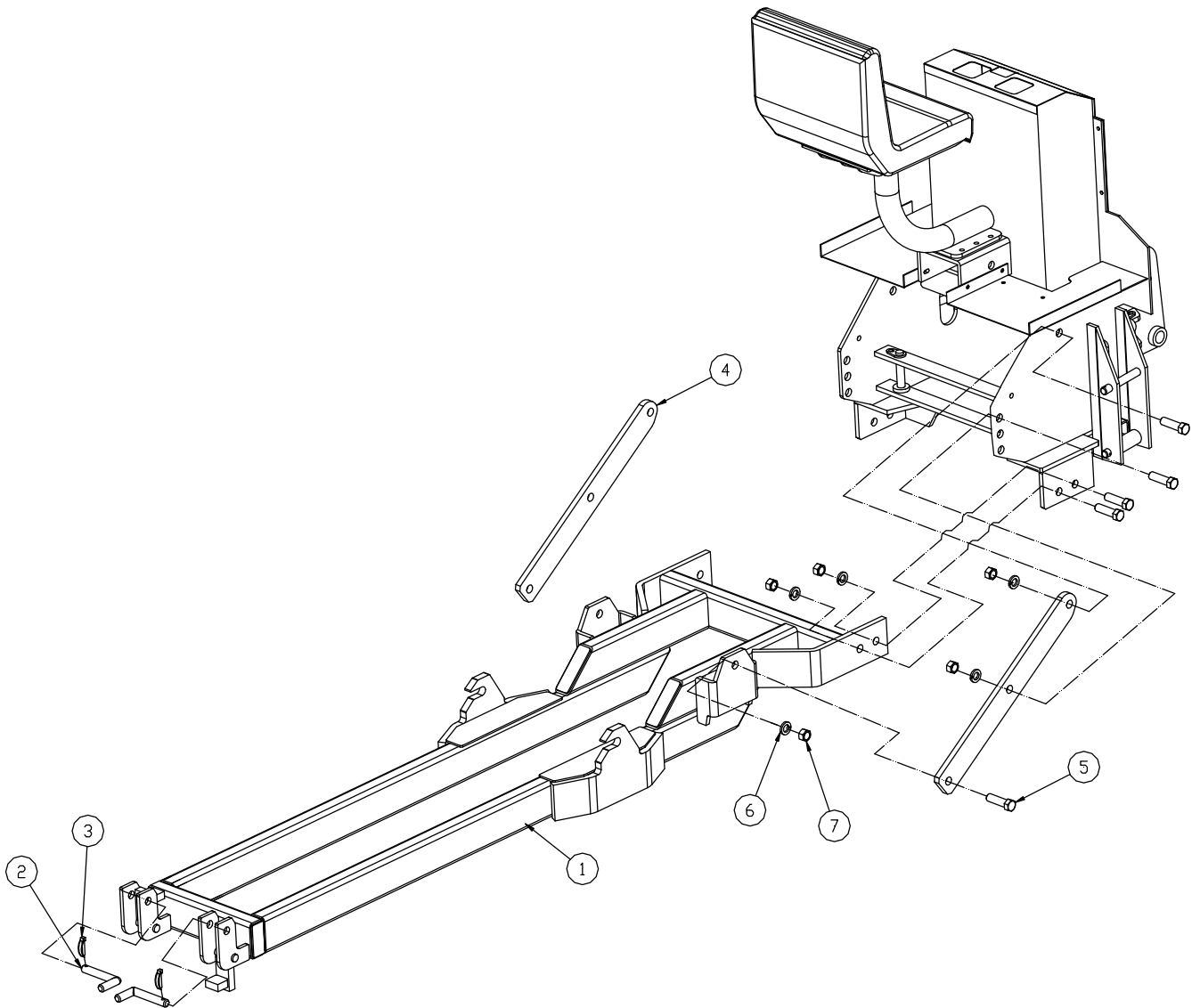



<b>SUB-FRAME</b>			<b>SPEC.</b>	<b>Q'TY</b>
<b>No.</b>	<b>Part No.</b>	<b>DESCRIPTION</b>		
1	BH200-900000GB	RAIL FRAME		1
2	BH200-901051	HOLD PIN		2
3	1461-306001	CHECK LINK PIN	Ø6	2
4	BH200-980000GB	STAY		2
5	0311-020065	BOLT	M20X2.5X65L	10
6	0931-020000	WASHER, SPRING	M20	10
7	0425-020000	NUT	M20X2.5	10

FIG.201

ASSEMBLY

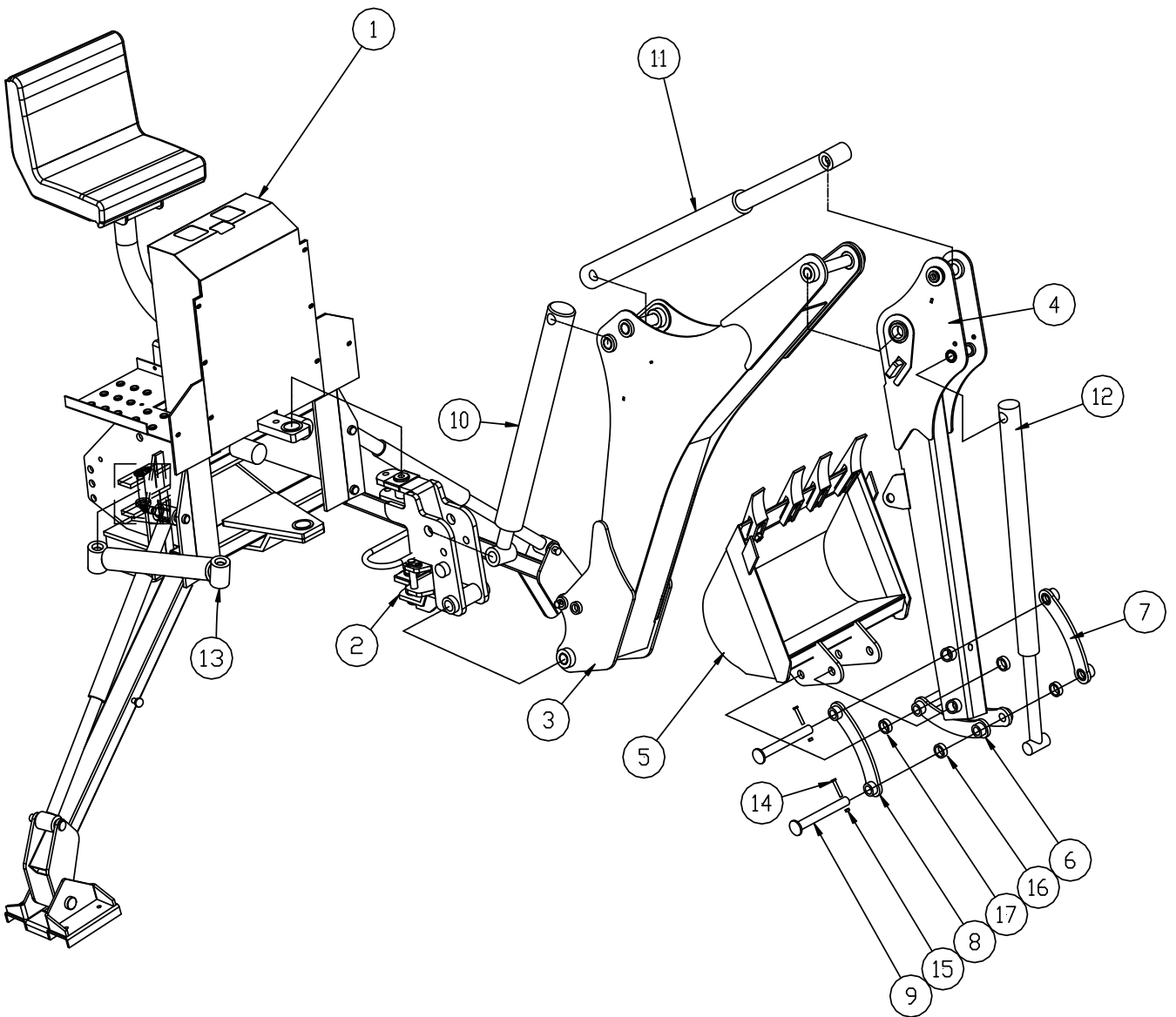

ASSEMBLY			SPEC.	Q'TY
No.	Part No.	DESCRIPTION		
1	YH200-101000GB	MAIN FRAME ASS'Y		1
2	YJ85-201001GB	SWING FRAME ASS'Y		1
3	YJ85-401002SR	BOOM FRAME ASS'Y		1
4	YJ85-501002SR	DIPPERSTICK FRAME ASS'Y		1
5	BY400-610002GB	BUCKET ASS'Y	9" (Option)	1
	BY400-620002GB	BUCKET ASS'Y	12" (Option)	1
	BH250-600001GB	BUCKET ASS'Y	16" (Standard)	1
	BY400-630003GB	BUCKET ASS'Y	18" (Option)	1
	BY400-640001GB	BUCKET ASS'Y	24" (Option)	1
	BY400-650001GB	BUCKET ASS'Y	36" (Option)	1
6	YJ85-661000GB	LINK A ASS'Y		1
7	BY400-670000GB	LINK LH		1
8	BY400-680000GB	LINK RH		1
9	YJ85-720000	PIN	Ø25 X 223L	2
10	H0119-052000SR	BOOM CYLINDER	Ø70 X Ø40 X 391ST	1
11	H0119-051000SR	DIPPERSTICK CYLINDER	Ø70 X Ø40 X 388ST	1
12	H0116-113001SR	BUCKET CYLINDER	Ø60 X Ø35 X 300ST	1
13	JW611305GB	SWING CYLINDER	Ø65 X Ø25 X 220ST	2
14	0321-008050	BOLT	M8X50L	2
15	0410-008000	NUT, NYLON	M8	2
16	0104-025025	DU BUSH	DU2525	2
17	0104-025030	DU BUSH	DU2530	2

FIG.301

MAIN FRAME ASSEMBLY

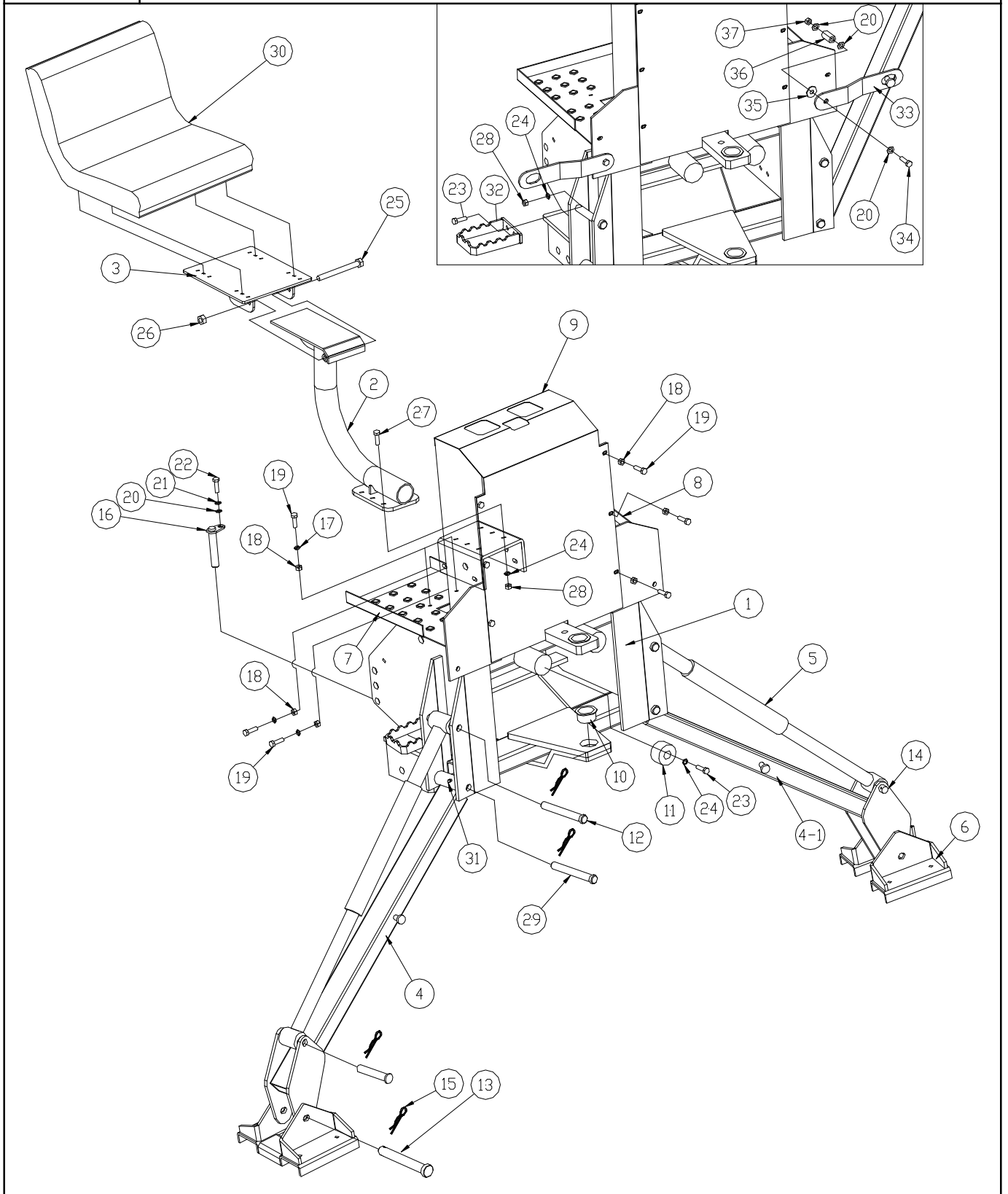

MAIN FRAME			DESCRIPTION	Q'TY	REMARK
No.	Part No.	PART NAME			
1	YH200-101002GB	MAIN FRAME		1	
2	BY85-110001GB	BRACKET		1	
3	BY85-110071GB	SEAT BRACKET		1	
4	YH250-311000GB	STABILIZER LH		1	
4-1	YH250-321000GB	STABILIZER RH		1	
5	H0120-024000GB	STABILIZER CYLINDER	Ø60 X Ø35 X 305ST	2	
6	YH200-331000GB	STABILIZER FOOT		2	
7	YH200-141001GB	FOOTSTOOL. LH	3.2T	1	
8	YH200-142001GB	FOOTSTOOL. RH	3.2T	1	
9	YJ85-104001GB	COVER	1.6T	1	
10	0104-045025	DU BUSH	Ø45 X Ø60 X 25L	2	
11	T300-200701	STOPPER	Ø60	2	
12	YJ85-120001	PIN	Ø25 X 150L	2	
13	YJ85-340001	PIN	Ø25 X 147L	2	
14	YJ85-320001	PIN	Ø25 X 124L	2	
15	0823-200024	R-PIN	A-20	8	
16	BY300-130001	PIN	Ø20 X 123L	2	
17	0930-008000	PLAIN WASHER	M8	8	
18	0420-008000	FLANGE NUT	M8	14	
19	0321-008025	BOLT	M8 X 25L	14	
20	0930-010000	PLAIN WASHER	M10	8	
21	0931-010000	SPRING WASHER	M10	2	
22	0322-010025	BOLT	M10 X 25L	2	
23	0310-012040	BOLT	M12 X 40L	6	
24	0931-012000	SPRING WASHER	M12	12	
25	0310-012160	BOLT	M12 X 160L	1	
26	0410-012000	NYLON NUT	M12	1	
27	0310-012035	BOLT	M12 X 35L	6	
28	0423-012000	NUT	M12	10	
29	YJ85-110002	PIN	Ø25 X 163L	2	
30	90202006100	SEAT		1	
31	0231-180000	GREASE NIPPLE	1/8	2	
32	BH200-121000GB	STEP		2	
33	BH250-311010	ROCK		2	
34	0322-010055	BOLT	M10 X 55L	2	
35	0930-010030	PLAIN WASHER	Φ10.5 X Φ30	2	
36	T300-200210	SPRING		2	
37	0410-010000	NYLON NUT	M10	2	

FIG.401

SWING FRAME ASSY

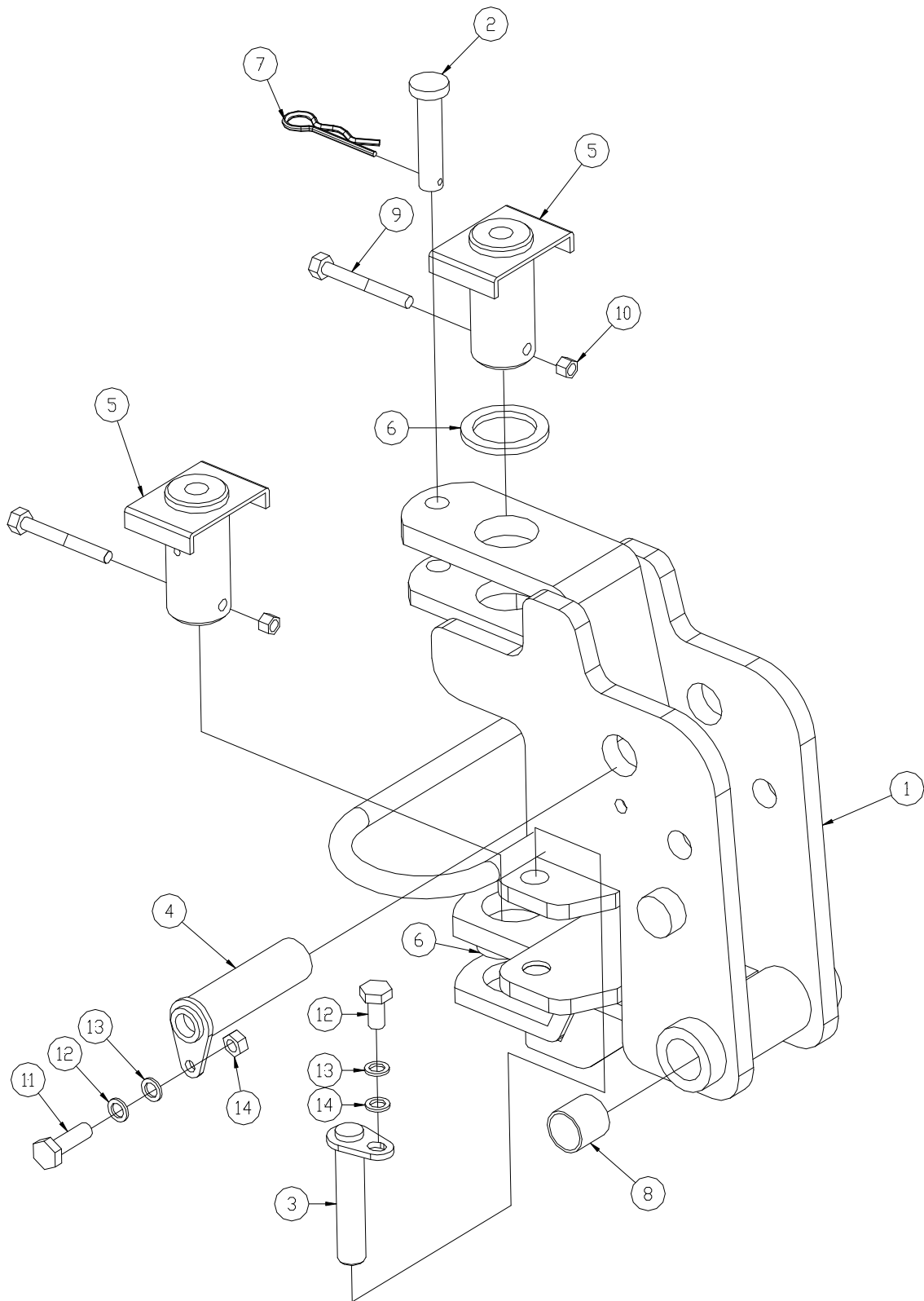

SWING FRAME			DESCRIPTION	Q'TY	REMARK
No.	Part No.	PART NAME			
1	YJ85-201001GB	SWING FRAME		1	
2	BY300-240001	PIN	Ø25 X 90L	1	
3	BY300-220001	PIN	Ø20 X 106L	2	
4	YJ85-230001	PIN	Ø32 X 120L	1	
5	BY300-210000	PIN	Ø45 X 107L	2	
6	BY300-250021	SHIM	9T X Ø74.5	2	
7	0823-200024	R-PIN	A-20	2	
8	0104-032030	DU BUSH	Ø32 X Ø36 X 30L	2	
9	0321-008065	BOLT	M8 X 65L	2	
10	0410-008000	LOCK NUT	M8	2	
11	0322-010025	BOLT	M10 X 25L	3	
12	0930-010000	PLAIN WASHER	M10	3	
13	0931-010000	SPRING WASHER	M10	3	
14	0422-010000	NUT	M10	1	

FIG.501

BOOM FRAME ASSY

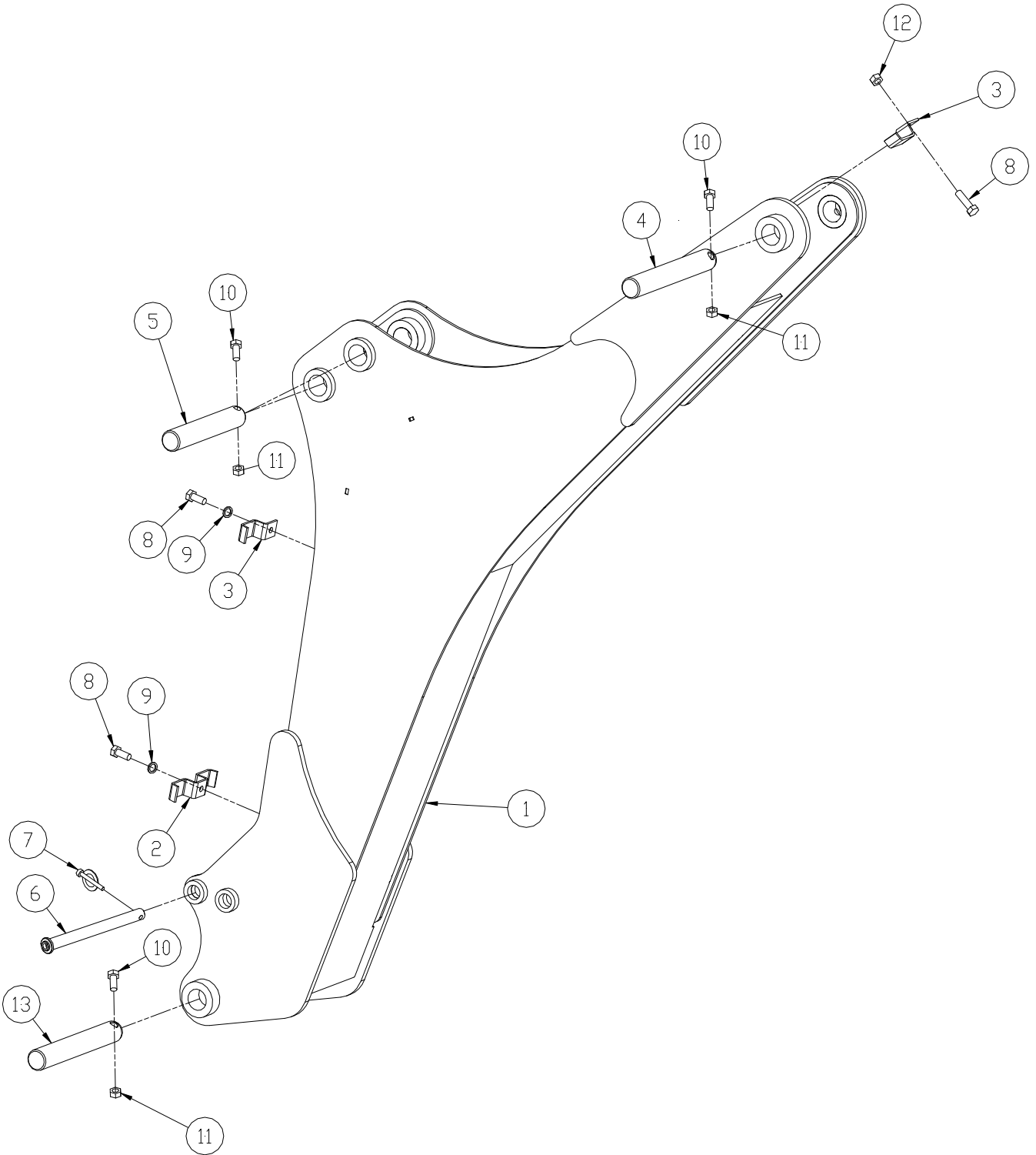



<b>BOOM FRAME</b>			<b>DESCRIPTION</b>	<b>Q'TY</b>	<b>REMARK</b>
<b>No.</b>	<b>Part No.</b>	<b>PART NAME</b>			
1	YJ85-401002SR	BOOM COMP		1	
2	Y100-004110	HOSE CLAMP B		1	
3	Y100-004100	HOSE CLAMP A		2	
4	YJ85-401141	PIN A_BOOM	Ø32 X 206L	1	
5	YJ85-401150	PIN B_BOOM	Ø32 X 188L	2	
6	YJ85-402000	LOCK PIN_BOOM	Ø20 X 215L	1	
7	1461-306002	LINK PIN	Ø6	1	
8	0320-008020	FLANGE BOLT	M8 X 1.25P X 20L	3	
9	0930-008000	PLAIN WASHER	M8	2	
10	0322-010065	BOLT	M10 X 1.5P X 65L	4	
11	0410-010000	NYLON NUT	M10 X 1.5P	4	
12	0420-008000	FLANGE NUT	M8	1	
13	YJ85-401160	PIN C_BOOM	Ø32 X 206L	1	

FIG.601

DIPPERSTICK FRAME ASSEMBLY

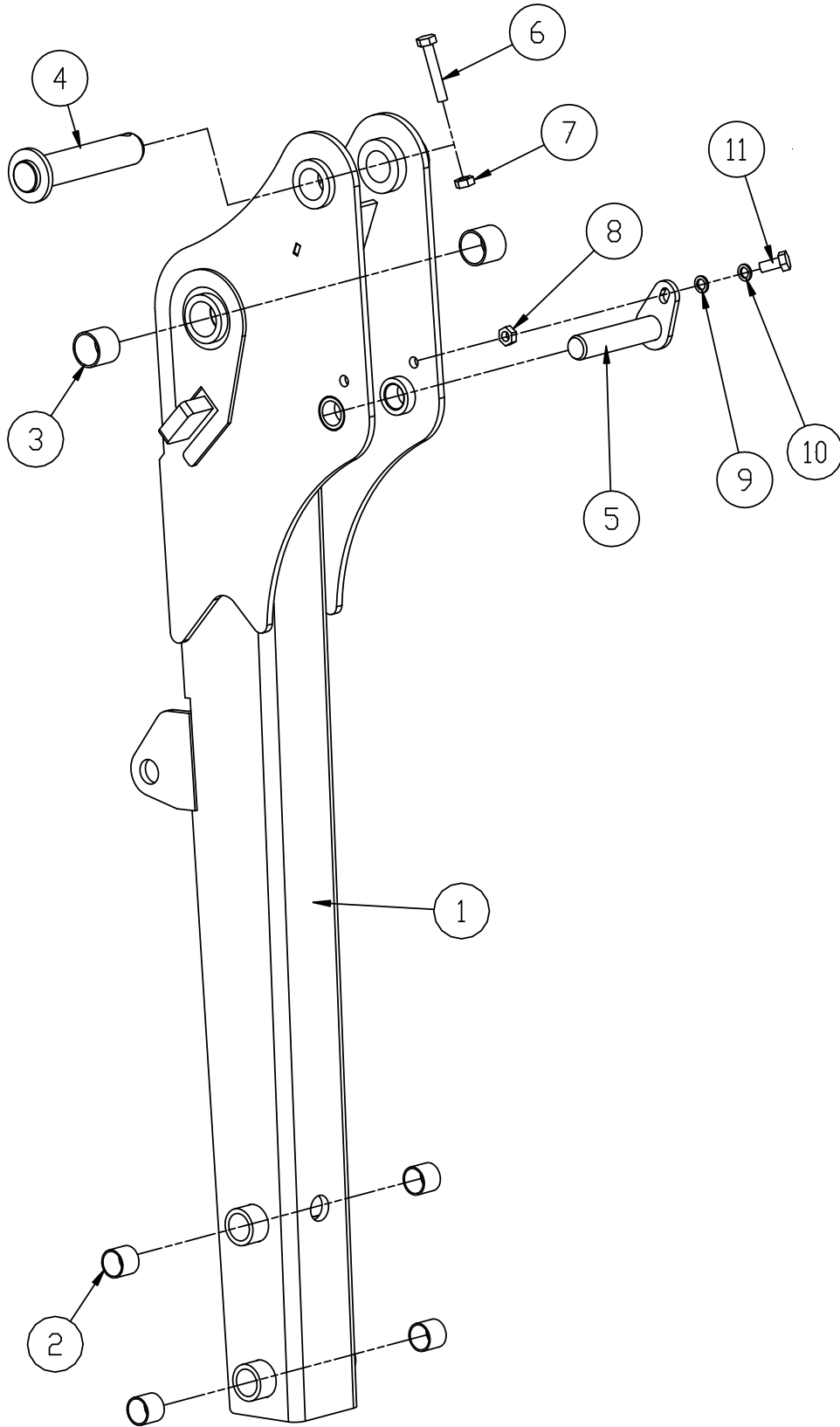

<b>DIPPERSTICK FRAME</b>			<b>DESCRIPTION</b>	<b>Q'TY</b>	<b>REMARK</b>
<b>No.</b>	<b>Part No.</b>	<b>PART NAME</b>			
1	YJ85-501001SR	DIPPERSTICK COMP		1	
2	0104-025030	DU BUSH	DU2530	4	
3	0104-032030	DU BUSH	DU3230	2	
4	YJ85-502000	PIN	Ø32 X 164L	1	
5	YJ85-503000	PIN	Ø25 X 126L	1	
6	0322-010060	BOLT	M10 X60L	1	
7	0410-010000	NYLON NUT	M10	1	
8	0422-010000	NUT	M10	1	
9	0930-010000	PLAIN WASHER	M10	1	
10	0931-010000	SPRING WASHER	M10	1	
11	0322-010030	BOLT	M10 X30L	1	

FIG.701

BUCKET FRAME & CONTROL VALVE ASSEMBLY

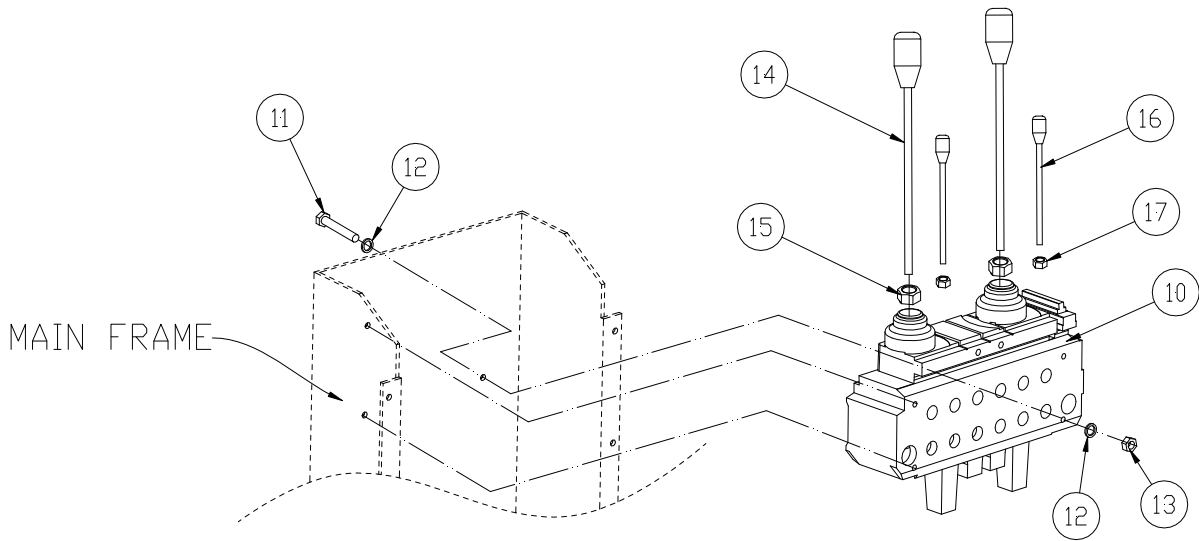
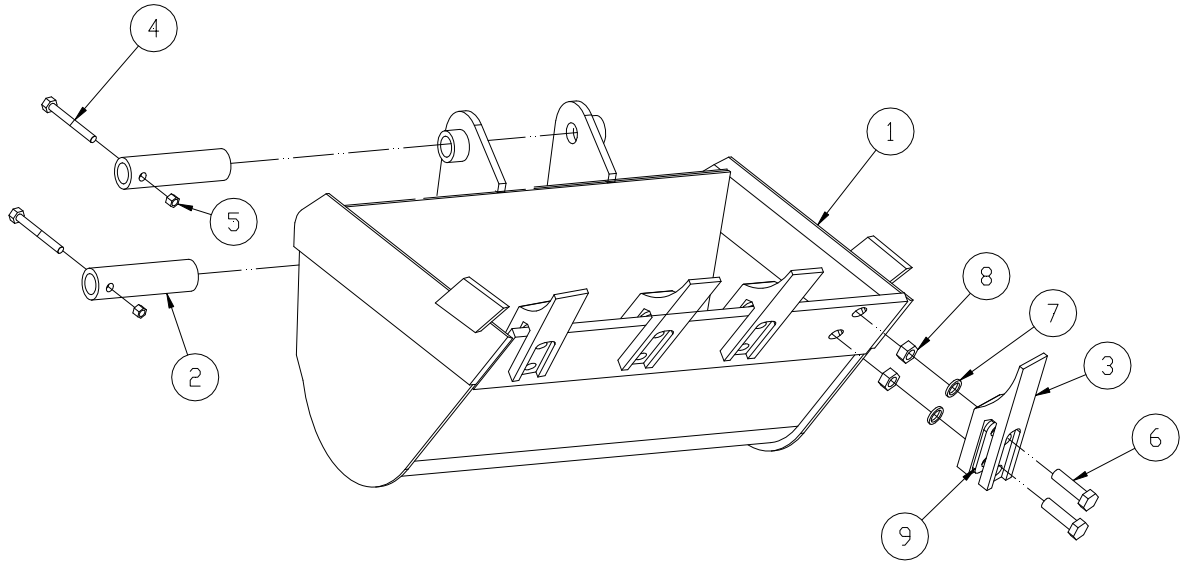

BUCKET FRAME & CONTROL VALVE			DESCRIPTION	Q'TY	REMARK
No.	Part No.	PART NAME			
1	BY400-611002GB	BUCKET COMP(NO TEETH)	9" (Option)	1	
	BY400-621002GB	BUCKET COMP(NO TEETH)	12" (Option)	1	
	BH250-601001GB	BUCKET COMP(NO TEETH)	16" (Standard)	1	
	BY400-631003GB	BUCKET COMP(NO TEETH)	18" (Option)	1	
	BY400-641001GB	BUCKET COMP(NO TEETH)	24" (Option)	1	
	BY400-651001GB	BUCKET COMP(NO TEETH)	36" (Option)	1	
2	YJ85-625000	PIN	Ø25 X 219L	2	
3	Y100-601080GB	TEETH		4	
4	0321-008050	BOLT	M8 X 50L	2	
5	0410-008000	LOCK NUT	M8	2	
6	0310-014050	BOLT	M14 X 50L	8	
7	0931-014000	SPRING WASHER	M14	8	
8	0424-014000	NUT	M14	8	
9	BY400-750001GB	SPACE,TEETH		4	
10	85105104002	CONTROL VALVE		1	
11	0322-010065	BOLT	M10 X 65L	2	
12	0930-010000	PLAIN WASHER	M10	2	
13	0410-010000	NYLON NUT	M10	2	
14	D1801-12300	LEVER ASS'Y(L)		2	
15	0422-010000	NUT	M10	2	
14	D1801-12400	LEVER ASS'Y(S)		2	
15	0421-008000	NUT	M8	2	

FIG.801

HOSE FITTING 1

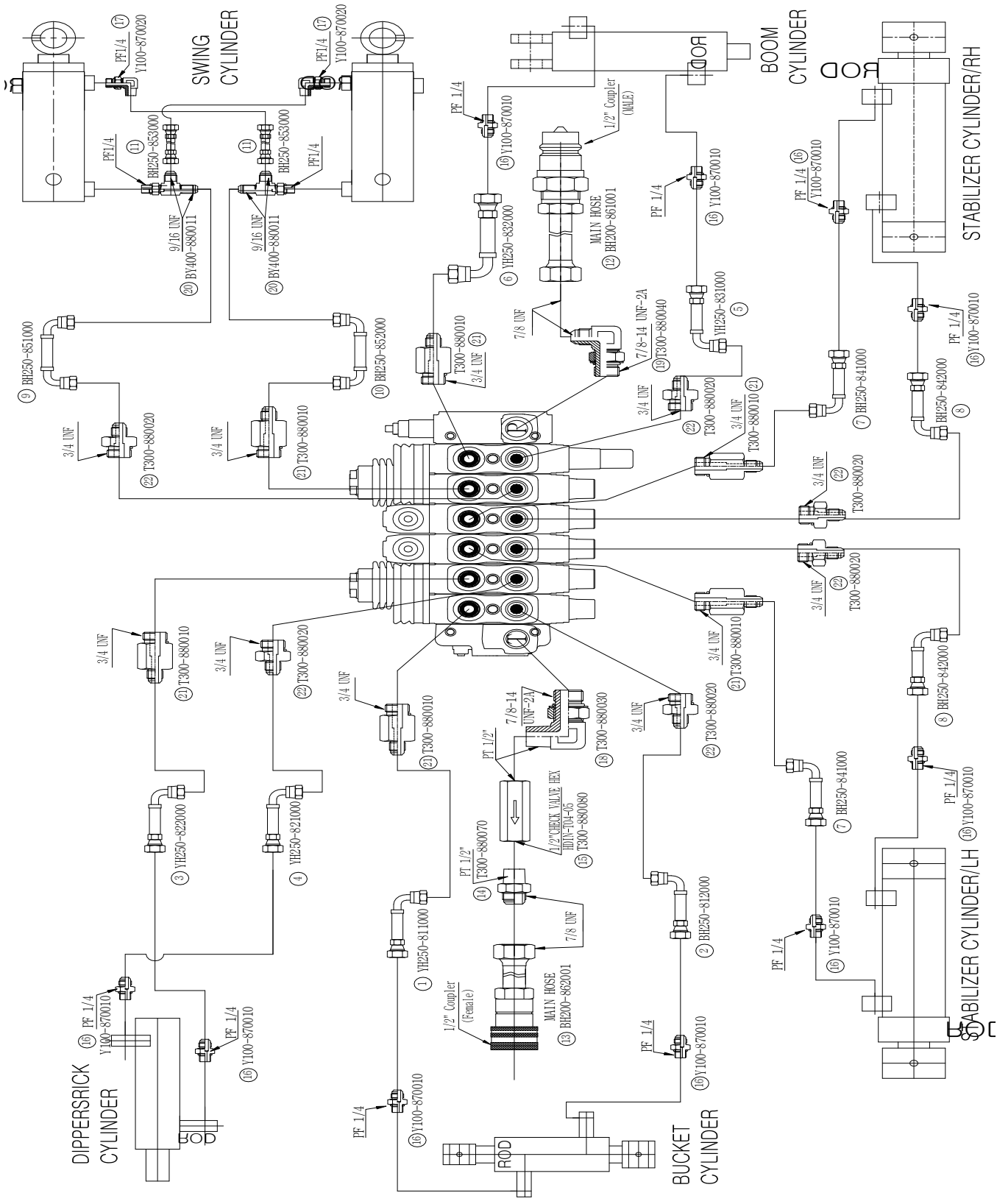
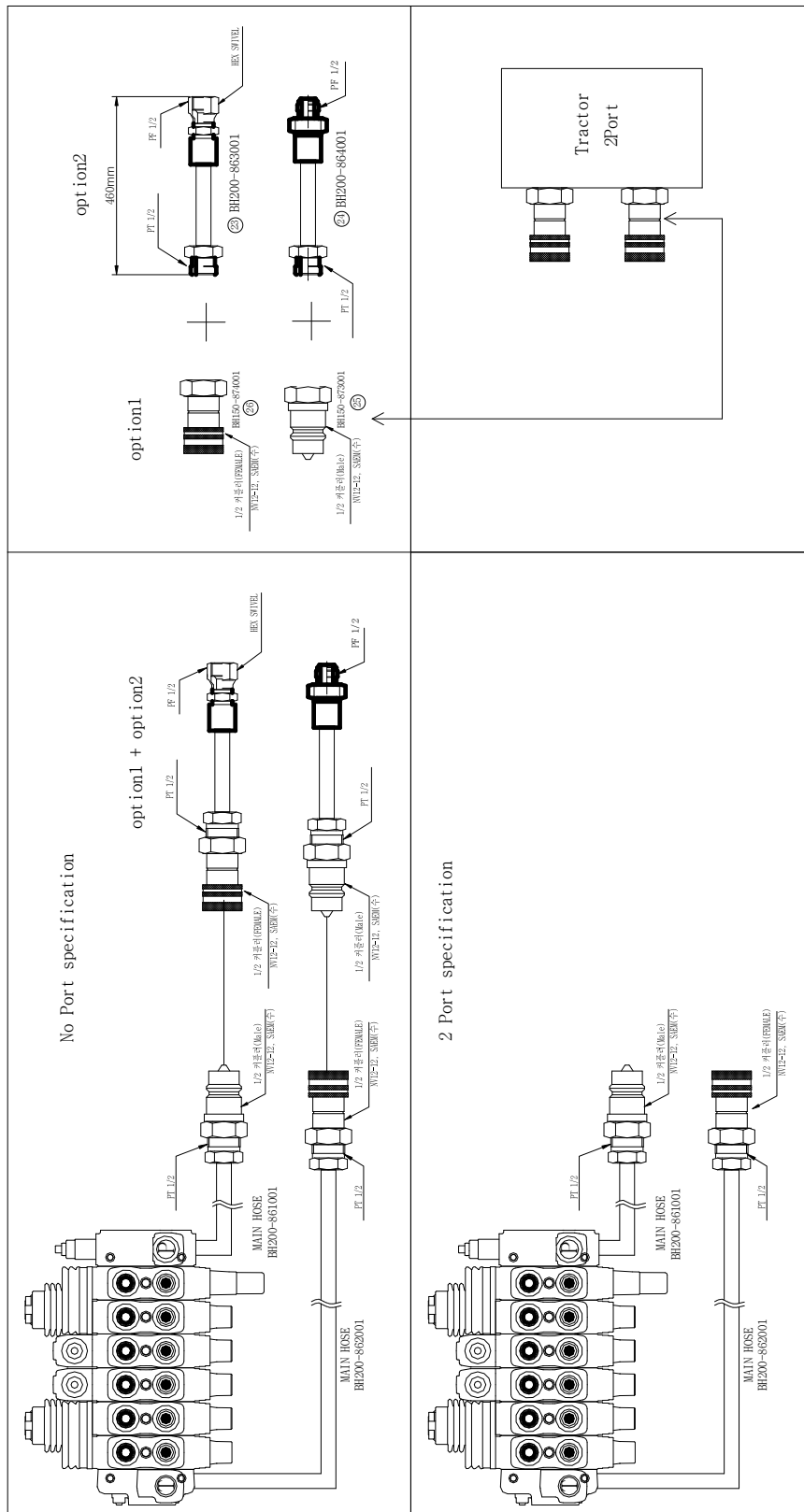

FIG.901

HOSE PITTING 2



<b>HOSE PITTING 1 &amp; 2</b>			<b>SPEC.</b>	<b>Q'TY</b>
<b>No.</b>	<b>Part No.</b>	<b>DESCRIPTION</b>		
1	YH250-811000	3700 HOSE BUCKET CY'L ROD	UNF 9/16 - UNF 9/16 90°	1
2	YH250-812000	3750 HOSE BUCKET CY'L BODY	UNF 9/16 - UNF 9/16 90°	1
3	YH250-821000	2700 HOSE DIPPERSTIC CY'L ROD	UNF 9/16 - UNF 9/16 90°	1
4	YH250-822000	2720 HOSE DIPPERSTIC CY'L BODY	UNF 9/16 - UNF 9/16 90°	1
5	YH250-831000	2010 HOSE BOOM CY'L ROD	UNF 9/16 - UNF 9/16 90°	1
6	YH250-832000	1930 HOSE BOOM CY'L BODY	UNF 9/16 - UNF 9/16 90°	1
7	BH250-841000	1520 HOSE STABILIZER CY'L ROD	UNF 9/16 - UNF 9/16 90°	2
8	BH250-842000	1570 HOSE STABILIZER CY'L BODY	UNF 9/16 - UNF 9/16 90°	2
9	BH250-851000	1000 HOSE SWING CY'L BODY A	UNF 9/16 - UNF 9/16 90°	1
10	BH250-852000	1050 HOSE SWING CY'L BODY B	UNF 9/16 - UNF 9/16 90°	1
11	BH250-853000	480 HOSE SWING CY'L ROD/T UNION	UNF 9/16 - UNF 9/16 90°	2
12	BH200-861001	1500 HOSE P PORT	1/2 COUPLER (M) - UNF 7/8	1
13	BH200-862001	1500 HOSE T PORT	1/2 COUPLER (F) - UNF 7/8	1
14	T300-880070	CHECK VALVE UNION	UNF 7/8 - PT 1/2	1
15	T300-880080	CHECK VALVE HEX	HDIN-T04 - 05(PT1/2)	1
16	Y100-870010	ADAPTER	9/16 - 1/4	10
17	Y100-870020	ELBOW 90°	PF1/4-UNF9/16 90°	2
18	T300-880030	ELBOW 90° - T PORT	UNF7/8 - PT1/2 90°	1
19	T300-880040	ELBOW 90° - P PORT	UNF7/8 - UNF7/8 90°	1
20	BY400-880011	T UNION	UNF9/16 - UNF9/16 - 1/4 T	2
21	T300-880010	NIPPLE 1	UNF9/16 - UNF3/4	6
22	T300-880020	NIPPLE 2	UNF9/16 - UNF3/4	6
23	BH200-863001	460 Extension HOSE T PORT	PT 1/2 - PF 1/2	1
24	BH200-864001	460 Extension HOSE P PORT	PT 1/2 - PF 1/2	1
25	BH150-873001	COUPLER (M)	PT 1/2 - 1/2 COUPLER (M)	1
26	BH150-874001	COUPLER (F)	PT 1/2 - 1/2 COUPLER (F)	1



Memo.

A large, vertically oriented rounded rectangle with a blue border and a light blue dot grid pattern, intended for writing a memo.